

INSTRUCTION MANUAL

Serial Number _____

269

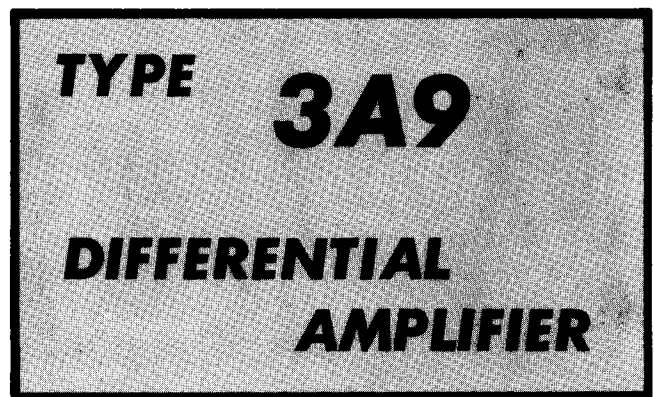



WARRANTY

All Tektronix instruments are warranted against defective materials and workmanship for one year. Tektronix transformers, manufactured in our plant, are warranted for the life of the instrument.

Any questions with respect to the warranty mentioned above should be taken up with your Tektronix Field Engineer.

Tektronix repair and replacement-part service is geared directly to the field, therefore all requests for repairs and replacement parts should be directed to the Tektronix Field Office or representative in your area. This procedure will assure you the fastest possible service. Please include the instrument Type and Serial or Model Number with all requests for parts or service.

Specifications and price change privileges reserved.

Copyright © 1968 by Tektronix, Inc., Beaverton, Oregon. Printed in the United States of America. All rights reserved. Contents of this publication may not be reproduced in any form without permission of the copyright owner.

CONTENTS

Section 1	Specification
Section 2	Operating Instructions
Section 3	Circuit Description
Section 4	Maintenance
Section 5	Performance Check/Calibration
	Abbreviations and Symbols
	Parts Ordering Information
Section 6	Electrical Parts List
	Mechanical Parts List Information
Section 7	Mechanical Parts List
Section 8	Diagrams
	Mechanical Parts List Illustrations

Abbreviations and symbols used in this manual are based on or taken directly from IEEE Standard 260 "Standard Symbols for Units", MIL-STD-12B and other standards of the electronics industry. Change information, if any, is located at the rear of this manual.

SEE PARTS LIST FOR SEMICONDUCTOR TYPES

SERIES M, MODEL 1, 2, 3



Fig. 1-1. Type 3A9 Differential Amplifier.

SECTION 1

SPECIFICATION

Change information, if any, affecting this section will be found at the rear of the manual.

Introduction

The Type 3A9 Vertical Plug-in is a DC coupled differential amplifier with excellent common-mode rejection and high gain characteristics for low level applications.

The DC Offset capability of the Type 3A9 allows the display of very small AC signals, containing a large DC component at deflection factors not possible with AC coupling. The vertical deflection factor of the Type 3A9 is variable from 10 μ V/Div through 10 V/Div. The high and low -3 dB frequencies which can be selected at the front panel, set the bandwidth. Thus, for low frequency applications the signal-to-noise ratio can be improved by restricting the bandwidth of the Type 3A9.

The Type 3A9 is designed for use in Tektronix Types 561A, 561B, 564, 564B, 565, and without digital readout in the Type 567/6R1A and 568/230. Used with the Type 129 Power Supply, the Type 3A9 can drive recorders, X-Y Plotters, oscilloscopes and other indicators.

The instrument will perform as stated under the Performance heading, within an ambient temperature range of 0° C to +50° C (after a 1 minute warmup) provided that the instrument has been calibrated within an ambient temperature range of +20° C to +30° C. Warmup time for given accuracy is 5 minutes.

ELECTRICAL CHARACTERISTICS

Characteristic	Performance Requirement
Deflection Factor Calibrated Range	10 μ V/DIV to 10 V/DIV; 19 steps in a 1-2-5 sequence, or 1 mA/DIV to 1 A/DIV
Accuracy Voltage	Within 2%
Current	Within 3%
Uncalibrated (Variable)	Continuously variable; extends deflection factor to at least 25 V/DIV.
Differential Dynamic Range	
10 μ V/DIV to 10 mV/DIV	± 1 V
20 mV/DIV to .1 V/DIV	± 10 V
.2 V/DIV to 1 V/DIV	± 100 V
2 V/DIV to 10 V/DIV	± 1000 V (500 V maximum, each input)

Characteristic	Performance Requirement
Frequency Response (Full Graticule Reference with voltage input)	
Overall Response DC (Direct) Coupled Input	DC to 1 MHz, -0% , $+30\%$
AC (Capacitive) Coupled Input, Lower Bandwidth Frequency	1.6 Hz within 5%
Bandwidth Limit (-3 dB points) Accuracy	
High	
1 MHz	0% to $+30\%$
300 kHz to 100 Hz	Within 12% of value indicated by UPPER -3 dB FREQUENCY setting. 9 steps in a 10-3-1 sequence
Low	
0.1 Hz to 10 kHz	Within 12% of value indicated by LOWER -3 dB FREQUENCY setting. 6 steps in a 100-10-1 sequence
Current Probe Frequency Response	At least 10 Hz to 1 MHz (-0% , $+30\%$)
Overdrive Recovery	10 μ s or less to recover to within 0.5% of zero level after removal of a + or - test input applied for at least 1 second. Test signal not to exceed differential dynamic range.
Common Mode Dynamic Range	
10 μ V/DIV to 10 mV/DIV	± 10 V
20 mV/DIV to .1 V/DIV	± 100 V
.2 V/DIV to 10 V/DIV	± 500 V
Input Overdrive Light	Indicates that differential overdrive is being approached.
Common-Mode Rejection Ratio	
DC (Direct) Coupled	See Graph, Fig. 1-2
AC (Capacitive) Coupled	See Graph, Fig. 1-2
Maximum AC Current	10 A, peak to peak

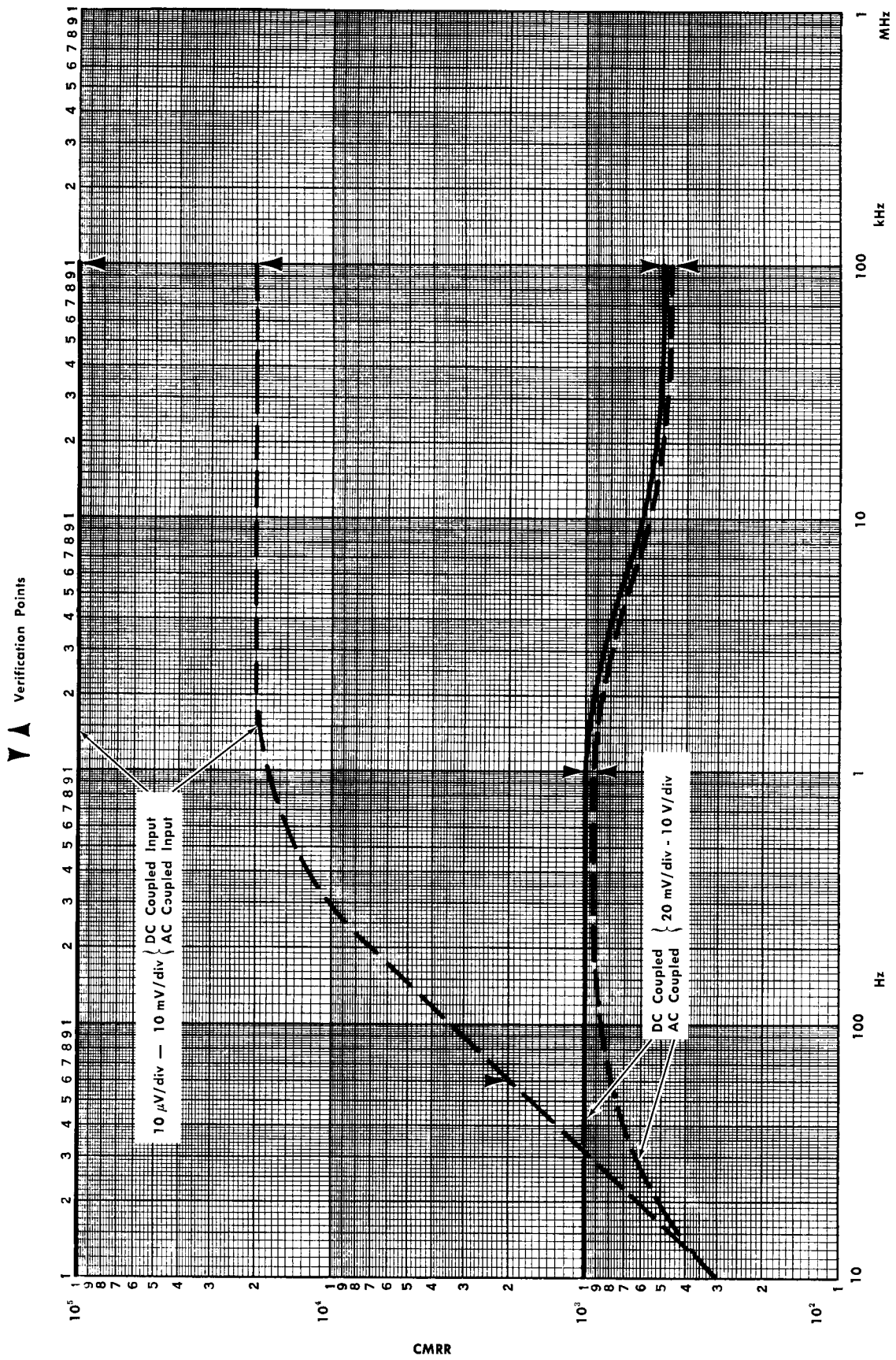

Fig. 1-2. CMRR vs Frequency, for Signals Not Exceeding Common-Mode Dynamic Range.

ELECTRICAL CHARACTERISTICS (Cont)

Characteristic	Performance Requirement
Maximum Input Voltage DC ((Direct) Coupled, DC plus peak AC 10 μ V/DIV to 10 mV/DIV 20 mV/DIV to 10 V/DIV AC (Capacitive) Coupled Input DC Voltage AC (Capacitive) Coupled Input DC Rejection	± 15 V ± 500 V ± 500 V, each input At least $4 \times 10^5:1$
Input R and C Resistance Capacitance Time Constant	1 M Ω , within 1% 47 pF, within 2.5 pF 47 μ s, within 4%
Maximum Input Gate Current 10 μ V/DIV to 10 mV/DIV 20 mV/DIV to 10 V/DIV Display Shift at 10 μ V/DIV AC Coupled	+25°C +50°C each input ± 20 pA ± 100 pA both inputs ± 40 pA ± 200 pA each input ± 10 pA ± 10 pA each input ± 2 cm ± 10 cm
Variable Balance	0.2 divisions or less shift as VARI- ABLE control is turned from fully clockwise to fully counterclock- wise position
Step Atten DC Balance	Adjustable for no position change while switching VOLTS/DIV-CUR- RENT/DIV
Displayed Voltage Noise Tangentially Measured	12 μ V or 0.1 div (whichever is greater) 1 MHz bandwidth, source resistance 25 Ω or less. See Sec- tion 5 for method of measurement.
DC Drift Drift with Time (Am- bient Temperature and Line Voltage Con- stant) Short Term	5 μ V/min (peak to peak) or 0.1 div (whichever is greater) after 1 hour warmup.

Characteristic	Performance Requirement
Long Term Drift with Ambient Temperature (Line Voltage Constant)	10 μ V/hour (peak to peak) or 0.1 div (whichever is greater) after 1 hour warmup. 50 μ V/ $^{\circ}$ C
Isolation between + and - Inputs (+INPUT to an Open - INPUT, -IN- PUT to an Open + IN- PUT) 10 μ V/DIV to 10 V/ DIV	At least 200:1, DC to 1 MHz.
Signal Output Dynamic Range Amplitude Amplitude Change Over Dynamic Range Bandwidth Output Resistance	At least +5 V to -5 V 1 V/Displayed Division, within 20% Within 2% DC to at least 500 kHz 100 Ω or less
DC Offset Coarse Range from Electrical Zero 10 μ V/DIV to 10 mV/DIV 20 mV/DIV to .1 V/DIV .2 V/DIV to 1 V/DIV 2 V/DIV to 10 V/DIV	+1 V to -1 V (within 10%) +10 V to -10 V (within 10%) +100 V to -100 V (within 10%) +1000 V to -1000 V (within 10%)

ENVIRONMENTAL

Characteristic	Performance Requirement
Temperature Non-operating Operating	-40°C to +65°C 0°C to +50°C
Altitude Non-operating Operating	To 50,000 feet To 15,000 feet
Transportation	Qualifies under National Safe Transit Committee test procedure 1A, Category II (24 inch drop)

SECTION 2

OPERATING INSTRUCTIONS

Change information, if any, affecting this section will be found at the rear of the manual.

FRONT PANEL

(See Fig. 2-1)

Introduction

This section opens with a brief functional description of the front-panel controls, INPUT OVERDRIVE light, input connectors, securing latch and SIGNAL OUTPUT connector. Following the front panel description is a familiarization procedure and finally a general discussion of the operation of the Type 3A9.

INPUT OVERDRIVE	Input overdrive indicator lamp. Indicates excessive differential drive to the input amplifier stage. An input of approximately 90% of the differential dynamic range between input connectors causes an overdrive indication.
VOLTS/DIV- CURRENT/DIV	Volts per displayed division-current per displayed division (charcoal-colored knob). Nineteen position switch used to select the calibrated deflection factors.
VARIABLE	Variable volts-current per division (red knob). Provides continuously variable uncalibrated attenuation between the calibrated deflection factors and extends the attenuation range to at least 25 V/DIV. Control is calibrated in the CAL position.
UNCAL	Indicates VARIABLE control is not in CAL detent.
GAIN	Screwdriver-adjust control to set the amplifier gain (CRT display scale factor) to agree with the VOLTS/DIV switch indication. Adjusted for proper deflection when the VOLTS/DIV is set to the 1 mV position.
POSITION	The control which vertically positions the trace or display.
UPPER —3 dB FREQUENCY	Nine-position switch which selects the approximate upper frequency —3 dB point. The switch positions are: .1, .3, 1, 3, 10 and 30 kHz; and .1, .3 and 1 MHz.
LOWER —3 dB FREQUENCY	Eight-position switch which selects DC OFFSET, DC or one of six low-frequency —3 dB points: .1, 1, 10 Hz and .1, 1 and 10 kHz.
+ INPUT	Signal input connector. Positive input produces upward deflection (see Fig. 2-2).

— INPUT	Signal input connector. Positive input produces downward deflection (see Fig. 2-2).
CURRENT PROBE	Current probe input. For use with 125-turn current probes (Tektronix P6016, P6019, P6021).
L F COMP	Compensates for low frequency losses of the current probe.
CURRENT/VOLTS	Two-position switch which selects Current or Voltage mode.
AC-GND-DC (+INPUT)	Three-position switch to select input coupling. AC and DC positions determine the method of coupling the signal to the preamp. The GND position disconnects the signal from the preamp and grounds the preamp input. The GND position also permits the coupling capacitor to charge before switching to AC to prevent overdriving the preamp.
AC-GND-DC (—INPUT)	Same function as the +INPUT coupling switch but applies to the —INPUT.
STEP ATTEN DC BAL (DC mode only)	Front-panel control for DC balancing the amplifier input stage. With no signal applied to the input connectors, the control is adjusted for no trace shift as the VOLTS/DIV switch is rotated from the 10 mV position to the 10 μ V position.
DC OFFSET (DC OFFSET mode only)	COARSE and FINE controls to provide internal offset bias while maintaining the differential capability. Available range of the offset bias depends upon the setting of the VOLTS/DIV switch, and is indicated by color-coded bands around the VOLTS/DIV switch.
SIGNAL OUTPUT	Signal output connector. Provides a DC coupled output signal at approximately 1 volt per displayed division (depending on CRT deflection factor).
SECURING LATCH	Gray knob near the bottom center of the front panel to lock the plug-in unit into the plug-in compartment.

FIRST TIME OPERATION

Preparation

Steps 1 through 5 in the following procedure are intended to help you get the trace on the screen quickly and pre-

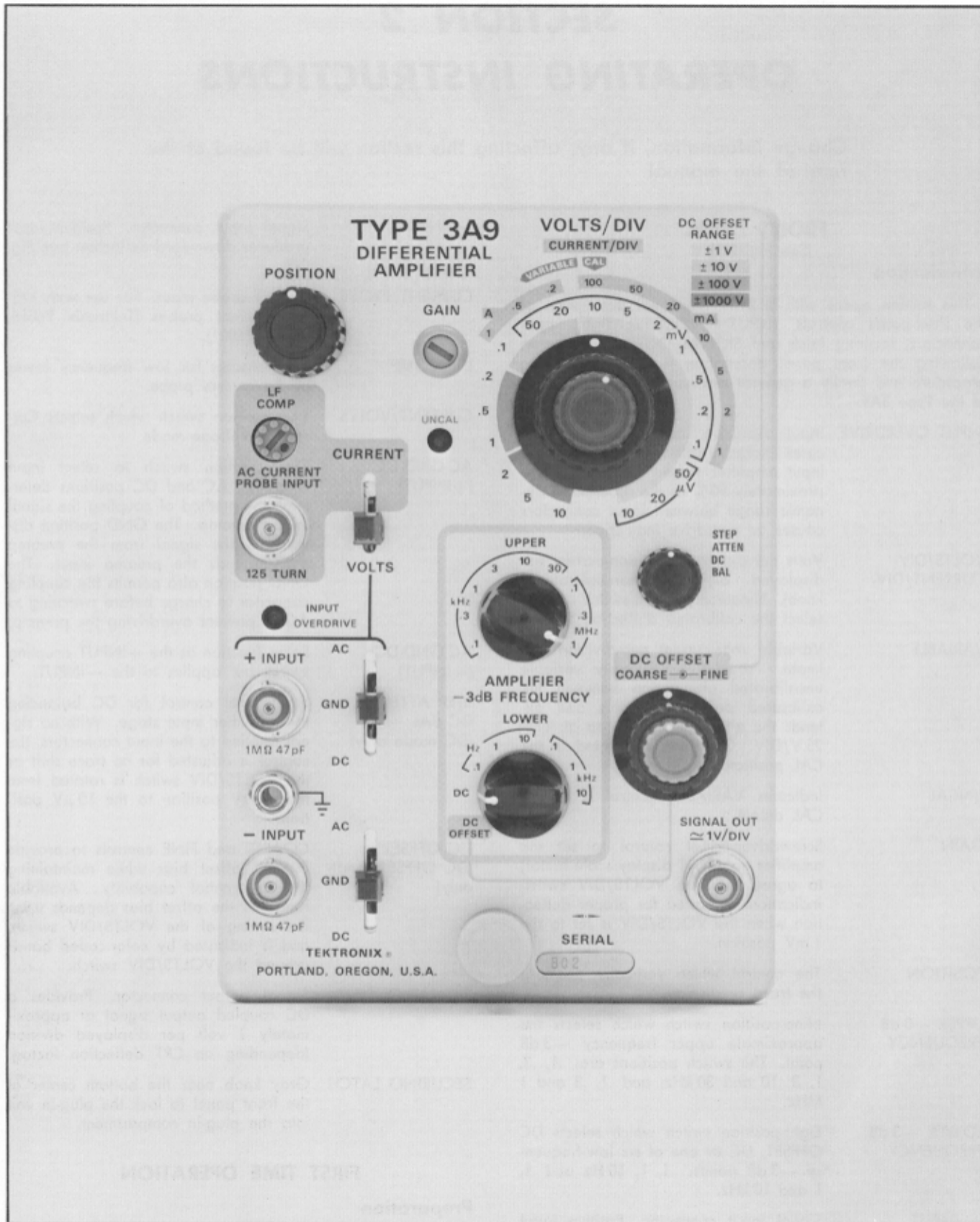

Fig. 2-1. Front-panel controls.

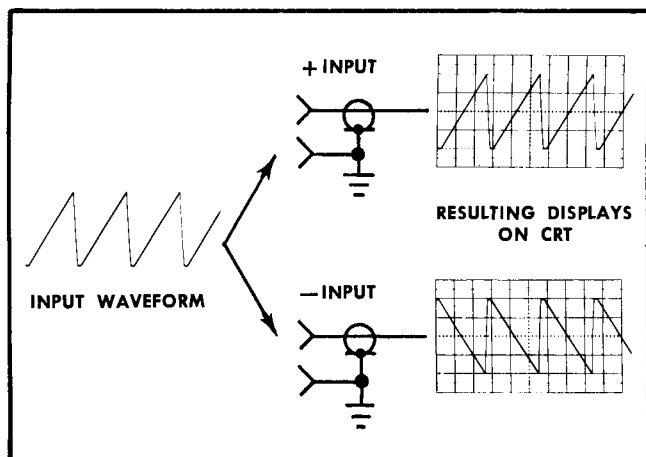

Fig. 2-2. Signals applied to the +INPUT connector produce an upright display, while signals applied to the -INPUT are inverted.

pare the unit for immediate use. Steps 6 through 8 are used to check the GAIN adjustment. These steps, along with those remaining, are intended to acquaint you with some of the basic functions of the Type 3A9.

1. Insert the unit into the oscilloscope plug-in compartment. Tighten the securing latch.

2. Set the Type 3A9 front-panel controls as follows:

VOLTS-CURRENT	VOLTS
VOLTS/DIV	1 mV
VARIABLE	CAL
POSITION	Midrange
UPPER -3 dB FREQUENCY	1 MHz
LOWER -3 dB FREQUENCY	DC
AC-GND-DC (+INPUT)	GND
AC-GND-DC (-INPUT)	GND
STEP ATTEN DC BAL	Midrange

3. Turn the oscilloscope Intensity control fully counter-clockwise and turn on the oscilloscope power. Preset the time base and triggering controls for a 0.5 ms/div sweep rate and automatic triggering.

4. Wait for about five minutes for the Type 3A9 and oscilloscope to warm up.

NOTE

About five minutes is sufficient time for warmup when using the Type 3A9 for short-term DC measurements. For long-term DC measurements using the lower deflection factors, allow at least one hour warmup time.

5. Adjust the oscilloscope Intensity control for normal viewing of the display. The trace should appear near the graticule center.

6. Using the Type 3A9 POSITION control, position the trace two divisions below the graticule center. This procedure assumes the oscilloscope graticule measures eight

divisions vertically. If the viewing area is less, adapt the procedure accordingly.

CAUTION

If the maximum input voltage rating is exceeded in the 10 μ V/DIV to 10 mV/DIV range of the VOLTS/DIV switch, the inputs are diode-clamped to fixed voltages of + and - 15 volts. If the signal source can supply more than 1/16 A, the input protective fuse(s) will open. An open input fuse is indicated by the lighting of the INPUT OVERDRIVE lamp when the input coupling switches are set to the GND position.

7. Apply a 4 mV peak-to-peak calibrator signal through a coaxial cable to the +INPUT connector on the Type 3A9.

8. For DC coupled, single-ended operation, set the +INPUT AC-GND-DC coupling switch to DC. The display should be square waves 4 divisions in amplitude with the bottom of the display at the reference established in step 6.

9. For AC coupled, single-ended operation, re-position the display with the Type 3A9 POSITION control to place the bottom of the display at the graticule center line.

10. Set the +INPUT AC-GND-DC coupling switch to AC and note that the display shifts downward about 2 divisions to its average level.

11. Disconnect the coaxial cable from the CAL OUT connector. Connect a BNC T adapter to the CAL OUT connector and connect two identical coaxial cables from the BNC T adapter to the +INPUT and the -INPUT.

12. For AC coupled differential operation, set the -INPUT AC-GND-DC coupling switch to AC. The calibrator signal is now coupled to both inputs as common-mode signal. A straight line display should be observed, since the common-mode signal is being rejected.

Operational Adjustments

After the unit has warmed up for at least an hour (five minutes, provided that the unit is not used below 1 mV/DIV or the STEP ATTEN DC BAL is readjusted every few minutes) and has stabilized, check its operation to determine whether adjustment of one or more of the controls is necessary. Be sure that the vertical system of the oscilloscope used in conjunction with the Type 3A9 is correctly calibrated (refer to the oscilloscope instruction manual), and that the calibrator output voltage is correct.

1. STEP ATTEN DC BAL. If the STEP ATTEN DC BAL is not properly adjusted, the CRT trace will shift vertically as the VOLTS/DIV switch is rotated through its range. The shift is more noticeable on the most sensitive positions.

a. Set the Type 3A9 front-panel controls as follows:

VOLTS/DIV	10 mV
VARIABLE	CAL
POSITION	Midrange
UPPER -3 dB FREQUENCY	1 MHz
LOWER -3 dB FREQUENCY	DC

Operating Instructions—Type 3A9

AC-GND-DC +INPUT	GND
AC-GND-DC -INPUT	GND
STEP ATTEN DC BAL	Midrange

b. Using the Type 3A9 POSITION control, position the CRT trace to the center of the graticule.

c. Set the VOLTS/DIV switch to 10 μ V.

d. Return the trace to graticule center by adjusting the STEP ATTEN DC BAL control.

NOTE

The adjustment of the STEP ATTEN DC BAL control should be checked periodically during the use of the instrument. If the Type 3A9 is used DC coupled or in significantly varying ambient temperatures in the 10 μ V/DIV to .1 mV/DIV ranges, the STEP ATTEN DC BAL should be checked quite frequently. It is good practice to check this control and readjust, if necessary, before any critical measurement is made under the above conditions.

2. GAIN. (This step may be performed after a five minute warm up).

a. Perform steps 1 through 8 in the First-Time Operation Procedure.

b. Adjust the GAIN control for exactly 4 divisions of display. Accuracy of this adjustment is dependent upon the voltage accuracy of the calibration source.

3. AC Atten Bal (internal adjustment). When the LOWER -3 dB FREQUENCY switch is used to limit the low frequency response of the Type 3A9 the unit employs AC stabilization. When the LOWER -3 dB FREQUENCY switch is set to any position other than DC to DC OFFSET, the STEP ATTEN DC BAL and DC OFFSET controls become inoperative and VOLTS/DIV balance is controlled with AC Atten Bal, an internal adjustment (see Fig. 2-3). When transferring the Type 3A9 from one oscilloscope to another, it may be necessary to perform a minor readjustment of this control due to normal power supply variations between oscilloscopes.

NOTE

An unbalance of up to 30 μ V is normal and cannot be reduced by adjusting the AC Atten Bal control.

The adjustment of this control in no way affects the calibration of the unit and may be performed without interaction with any other controls.

a. With the Type 3A9 inserted into the oscilloscope, remove the left-side panel of the oscilloscope. Set the Type 3A9 controls as follows:

VOLTS/DIV	10 mV
AC-GND-DC (+INPUT and -INPUT)	GND
LOWER -3 dB FREQUENCY	10 kHz
UPPER -3 dB FREQUENCY	100 Hz

b. Using the Type 3A9 POSITION control, position the trace to graticule center.

c. Set the VOLTS/DIV switch to 20 μ V.

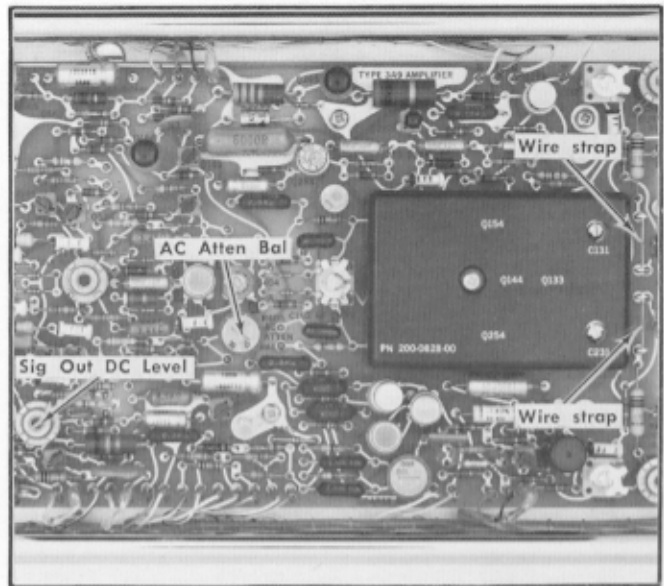

Fig. 2-3. Location of controls on Amplifier circuit board.

d. Adjust the AC Atten Bal control, R405, to position the trace to within 1.5 divisions of graticule center. See note in step 3.

4. Signal Out DC Level (Internal Adjustment). When first operating the Type 3A9 or when changing main frames, the Signal Out DC Level should be checked. The DC level at the SIGNAL OUT connector should be zero volts when the trace is centered on the CRT. This adjustment in no way affects the calibration of the unit and may be performed without interaction with any other controls.

a. Set the Type 3A9 controls as follows:

VOLTS/DIV	10 mV
AC-GND-DC (+INPUT and -INPUT)	GND
LOWER -3 dB FREQUENCY	DC
UPPER -3 dB FREQUENCY	1 MHz

b. Using the Type 3A9 POSITION control, position the trace to graticule center.

c. Connect a DC voltmeter or a test oscilloscope to the SIGNAL OUT connector and measure the DC level.

d. With the left-side panel of the oscilloscope removed, adjust the Sig Out DC Level, R467, for zero volts out at the SIGNAL OUT connector (see Fig. 2-1).

GENERAL OPERATING INFORMATION

Trace Drift

The environment in which the Type 3A9 is operated and the inherent characteristics of the Type 3A9 influence trace drift. Therefore, to determine trace drift for a specific environment, refer to the Specification section of this manual. In an environment in which the ambient temperature does

not vary much (such as an air conditioned laboratory) the trace drift generally will not exceed $10 \mu\text{V}$ in one hour.

To obtain accurate DC measurements at maximum sensitivity, it is necessary to ground the inputs and DC balance the amplifier just before making the measurement. This is accomplished by adjusting the STEP ATTEN DC BAL control as described earlier in this section under Operational Adjustment No. 1.

When using the .1 mV to $10 \mu\text{V}$ ranges for measurements with an AC coupled input, or for DC measurements where the source impedance is high (in excess of $1 \text{ M}\Omega$), the input gate current should be checked and allowed for, or adjusted to zero. This is particularly desired at high ambient temperatures (above 40°C). Steps 7 and 8 in the Performance Check/Calibration Procedure describe the check and adjust procedures for setting gate current to zero.

Applying Signals

When measuring DC voltages, use the largest deflection factor (10 V/DIV) when first connecting the Type 3A9 to an unknown voltage source. If the deflection is too small to make the measurement, switch to a lower deflection factor. If the input stage is overdriven, a large amount of current might flow into the input. See CAUTION after item 6 of First Time Operation.

Where only the AC component of a signal having both AC and DC components is to be measured, take advantage of the precharging circuit incorporated in the unit. The pre-charging circuit incorporated in the unit. The pre-charging circuit permits charging the coupling capacitor to the DC source voltage when the AC-GND-DC input coupling switch is set to GND. The procedure for using this circuit is as follows:

- a. Before connecting the Type 3A9 to a signal containing a DC component, set the AC-GND-DC input coupling switch to GND. Then connect the input to the circuit under test.
- b. Wait about one second for the coupling capacitor to charge.
- c. Set the input coupling switch to AC. The display will remain on-screen and the AC component can be measured in the usual manner.
- d. On completion of the measurement, set the AC-GND-DC switch to GND.

The above procedure should be followed whenever a signal having a different DC level is connected.

CAUTION

If the Type 3A9 input is connected to a large DC voltage source without using the pre-charge provision, the peak charging current will be limited only by the signal source, and this source may be damaged or destroyed.

When a large DC voltage has been applied to the Type 3A9 with the input AC coupled, the input coupling capacitor(s) acquires a charge and acts as a high impedance voltage source with a very slowly decaying output voltage. This voltage can offset subsequent AC coupled measurements at

other DC voltages and drive the trace off-screen. A period of at least 10 minutes, with input set to GND, should be allowed to assure reasonable recovery from polarization, and a longer period may be necessary for critical measurements.

Signal Input Connectors

When connecting signals to the +INPUT and -INPUT connectors on the Type 3A9, consider the method of coupling that will be used. Sometimes unshielded test leads can be used to connect the Type 3A9 to a signal source, particularly when a high level, low-frequency signal is monitored at a low impedance point. However, when any of these factors is missing, it becomes increasingly important to use shielded signal cables. In all cases, the signal-transporting leads should be kept as short as practical.

When making single-ended input measurements (conventional amplifier operation), be sure to establish a common ground connection between the device under test and the Type 3A9. The shield of a coaxial cable is normally used for this purpose.

In some cases, differential measurements require no common ground connection,¹ and therefore are less susceptible to interference by ground-loop currents. Some problems with stray magnetic coupling into the signal-transporting leads can also be minimized by using a differential rather than a single-ended measurement. These considerations are discussed later in this section under Differential Operation.

It is always important to consider the signal source loading (and resulting change in the source operating characteristics) due to the signal-transporting leads and the input circuit of the Type 3A9. The circuit at the input connectors can normally be represented by a 1 megohm resistance to ground paralleled by 47 pF. A few feet of shielded cable (20 to 40 pF per foot) may increase the parallel capacitance to 100 pF or more. In many cases, the effects of these resistive and capacitive loads may be too great and it may be desirable to minimize them through the use of an attenuator probe.

Attenuator probes not only decrease the resistive and capacitive loading of a signal source, but also extend the measurement range of the Type 3A9 to include substantially higher voltages. Passive attenuator probes having attenuation factors of 10 \times , 100 \times and 1000 \times , as well as other special-purpose types are available through your Tektronix Field Engineer or Field Office.

Some measurement situations require a high resistance input to the Type 3A9 with very little source loading or signal attenuation. In such situations a passive attenuator probe cannot be used. However, this problem may be solved by using a FET Probe or the high impedance input provision of the Type 3A9.

The high impedance input provision applies only to DC coupled signals which permit the use of the 10 mV through $10 \mu\text{V}$ positions of the VOLTS/DIV switch. Since no input attenuator is used at these switch positions, the internal gate return resistor alone establishes the 1 megohm input resistance. This resistor in each input can be disconnected by

¹The DC plus AC voltages on the test points (with respect to the chassis potential of the Type 3A9) should be limited to the levels listed in Section 1 under Maximum Common-mode Input Voltage characteristics. Higher levels will degrade the common-mode rejection ratio and exceed the input voltage rating of the unit.

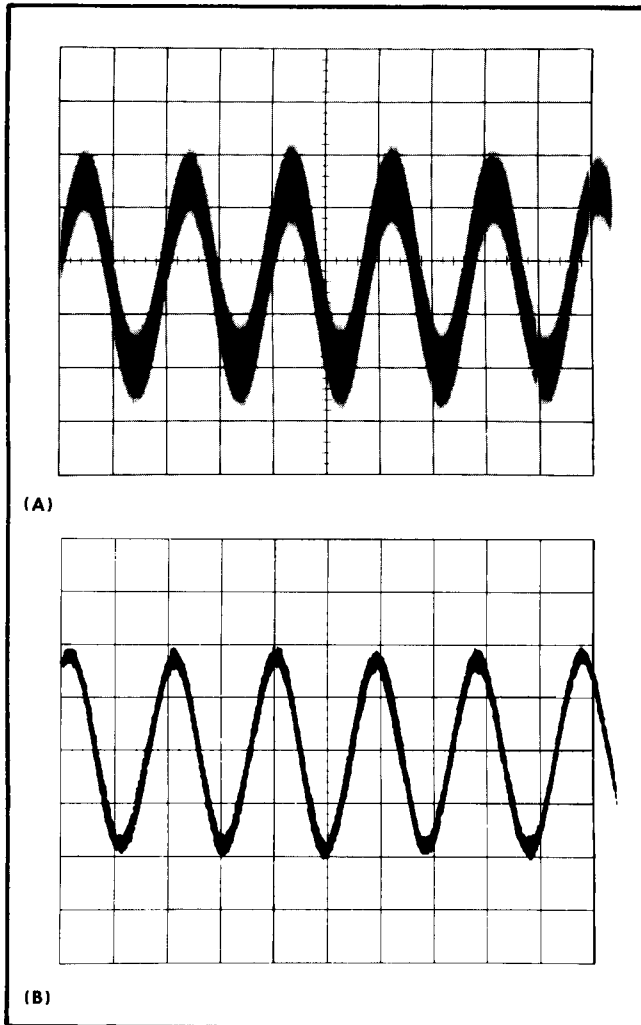

Fig. 2-4. Improving signal-to-noise ratio by setting bandwidth. (A) Lower -3 dB FREQUENCY selector to DC, UPPER -3 dB FREQUENCY, 1 MHz. (B) Lower -3 dB FREQUENCY selector to DC, UPPER -3 dB FREQUENCY, 10 kHz.

removing a wire strap from the amplifier circuit board (see Fig. 2-4). The signal source must then provide a DC path for the FET gate current.

IMPORTANT

When the wire straps are removed from the attenuator circuit board, the +Gate Current and -Gate Current internal adjustments are disconnected. The deflection factors in the 20 mV to 10 V range will be incorrect.

The uncompensated gate current is typically less than 100 picoamperes, but may be several times higher depending upon the operating temperature. The signal source impedance is therefore an important factor since gate current will produce a DC offset. For example, a 100 picoampere gate current through 10 megohms produces a 1 mV offset, which may result in significant error where small voltages are of concern.

The high frequency response will also depend upon the signal source impedance, since various shunt capacitances

between the source and the input gate must charge and discharge through that impedance.

Display Polarity

Single-ended signals can be applied to either the +INPUT or - INPUT connector. If the +INPUT is chosen, positive-going changes in the input signal will cause the trace to be deflected upward, and negative-going changes will cause the trace to be deflected downward. If the -INPUT is chosen, input-to-display polarity relationship will be reversed, as shown previously in Fig. 2-2.

Deflection Factor

The amount of trace deflection produced by a signal is determined by the signal amplitude, the attenuation factor (if any) of the probe, the setting of the VOLTS/DIV switch and the setting of the VARIABLE control. The calibrated deflection factors indicated by the VOLTS/DIV switch apply only when the VARIABLE control is set fully clockwise into the switch detent CAL position.

The range of the VARIABLE control is at least 2.5:1. It provides uncalibrated deflection factors covering the full range between the fixed settings of the VOLTS/DIV switch. The control can be set to extend the deflection factor to at least 25 volts/div.

To reduce noise and obtain a more usable display when the VOLTS/DIV switch is set to the most sensitive positions, use the lowest bandwidth setting which does not appreciably distort the desired features of the signal under observation. It is suggested that the UPPER -3 dB FREQUENCY switch be set to 30 kHz or less for the 10 μ V position and 100 kHz or less for the 20 μ V and 50 μ V positions. See Fig. 2-5.

Voltage Comparison Measurements

Some applications require deflection factors other than the fixed values provided by the VOLTS/DIV switch. One such application is comparison of signal amplitudes by ratio rather than by absolute voltage. To accomplish this, apply a reference signal to either input of the Type 3A9, and set the VOLTS/DIV switch and VARIABLE so that the reference display covers the desired number of graticule divisions. Do not change this setting of the VARIABLE control throughout the subsequent comparisons. The settings of the VOLTS/DIV switch can be changed, however, to accommodate large ratios. In doing so, regard the numbers which designate the switch positions as ratio factors rather than voltages.

Differential Operation

Single-ended measurements often yield unsatisfactory results because of interference resulting from ground-loop currents between the oscilloscope and the device under test. In other cases, it may be desirable to eliminate a DC voltage by means other than the use of a DC-blocking capacitor, which would limit the low-frequency response.

These limitations of single-ended measurements are virtually eliminated using differential measurements. Differential measurement is made by connecting each of the inputs

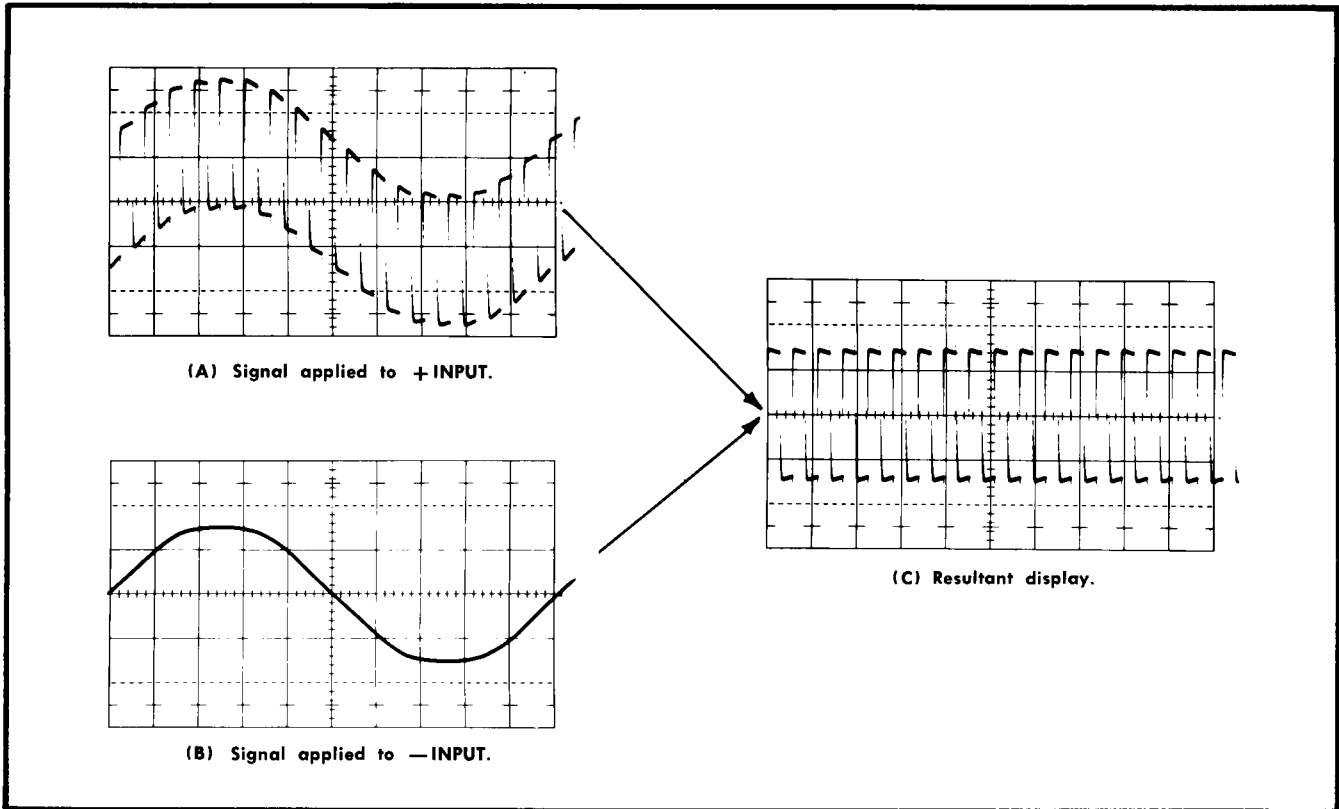

Fig. 2-5. Typical waveforms showing (A) and (B) signals to + and - INPUTS and (C) resultant waveform.

(+INPUT, -INPUT) to selected points in the test circuit. Since the chassis of the Type 3A9 need not be connected in any way to the test circuit, there are few limitations to the selection of these test points.

Both AC-GND-DC input coupling switches should be set to the same position, AC or DC, depending on the method of signal coupling required.

Only the voltage difference between two signals is amplified and displayed in differential measurements, while the common-mode signals (common in amplitude, frequency and phase) are rejected. See Fig. 2-6.

The ability of the Type 3A9 to reject common-mode signals is indicated in the common-mode rejection ratio (CMRR). CMRR is at least 100,000:1 at the input connectors for the lowest deflection factors (10 μ V/DIV to 10 mV/DIV) when signals between DC and 100 kHz are DC coupled to the inputs. To illustrate this characteristic, assume that a single-ended input signal consists of an unwanted 60 Hz signal at 1 volt peak to peak, plus a desired signal at 1 mV peak to peak. If an attempt is made to display the described signal (single-ended measurement) at .2 mV/DIV, the 60 Hz signal would produce a deflection equivalent to 5000 divisions and the 1 mV signal would be lost.

If the same 1 mV signal is measured differentially with the 60 Hz signal common to both inputs, no more than one part in 100,000 of the common-mode signal will appear in the display. Thus, the desired signal will produce a display of 5 divisions with not more than 0.05 divisions of display produced by the common-mode signal.

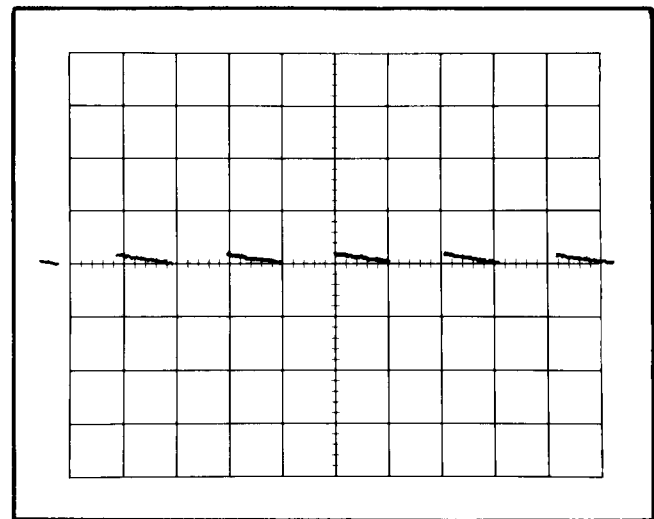

Fig. 2-6. Adjustment of Current Probe LF COMP.

There are a number of factors which can degrade common-mode rejection. The principal requirement for maximum rejection is for the common-mode signal to arrive at the input FET gates in precisely the same form. A difference of only 0.01% in the attenuation factors of the input attenuators may reduce the rejection ratio to 10,000:1. Likewise, any difference in source impedance at the two points in the source under test will degrade the rejection

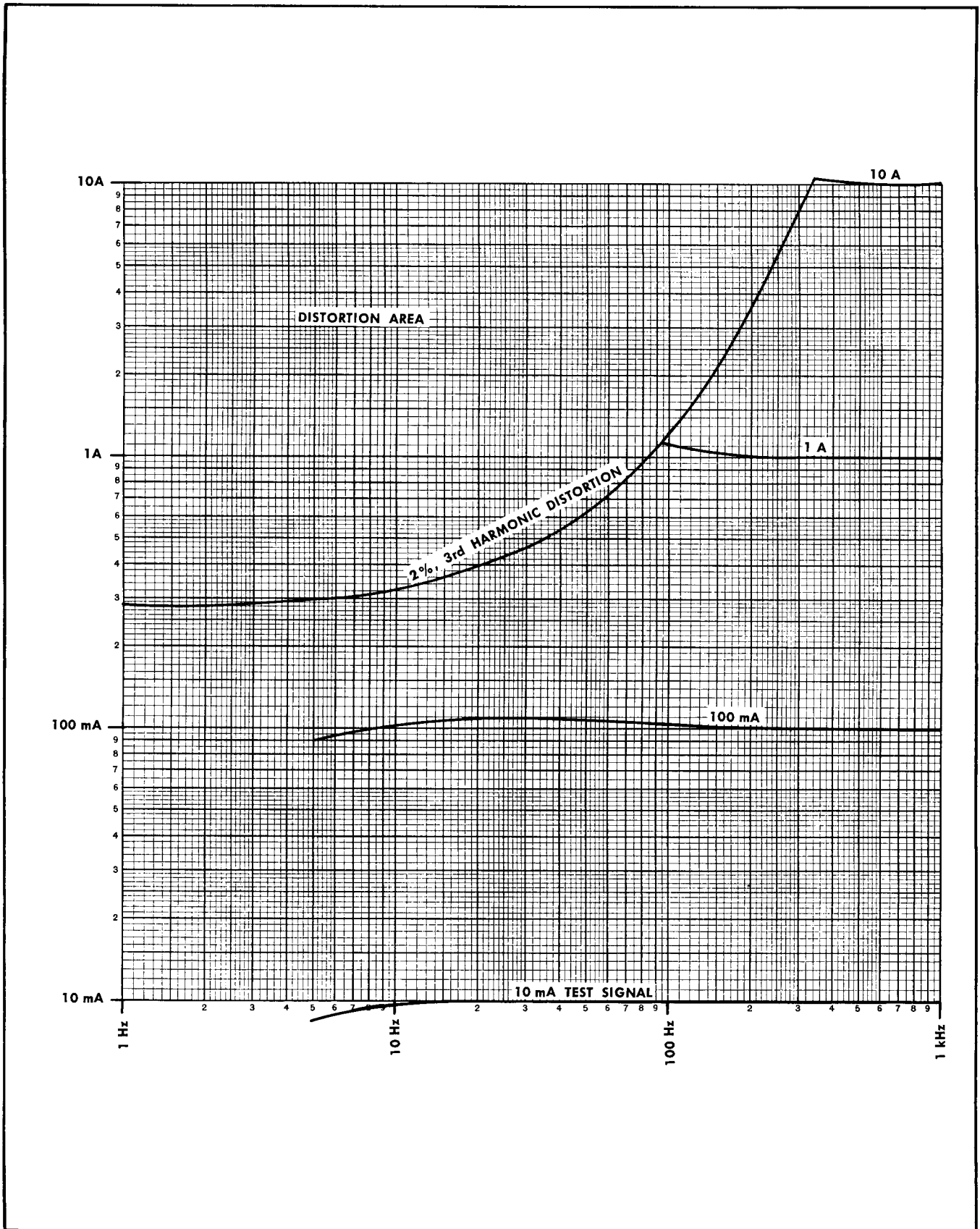

Fig. 2-7. Low Frequency characteristics at various current levels.

As you have to use probe attenuator even in case of diff

ratio. Attenuator probes which do not have adjustable R and C may reduce the rejection ratio to 100:1 or less.

Outside influences such as magnetic fields can also degrade the performance, particularly when low level signals are involved. Magnetic interference may be minimized by using identical signal-transporting leads to the two inputs and twisting the two leads together over as much of their length as possible.

Voltage Probes

The following adjustment procedure is recommended when preparing to use Tektronix P6023 probes for differential measurement.

a. Connect one probe for DC-coupled single-ended input. Obtain a triggered display of an appropriate square wave, such as that from the oscilloscope amplitude calibrator. Adjust the probe DC Atten Calibration control for correct deflection sensitivity, then compensate the probe square-wave response using the AC Fine Comp adjust and the AC Coarse Comp adjust if necessary.

b. Connect a second probe for DC-coupled operation. Apply the square wave to both probes at 100 volts peak to peak. Free run the oscilloscope sweep and adjust the DC Atten Calibration of the second probe for maximum low frequency cancellation (minimum signal amplitude, or elimination of the two-trace appearance).

c. Adjust the AC Fine Comp and the AC Coarse, if necessary, of the second probe to minimize the amplitude of the differential pulses on the displayed trace.

d. The above procedure matches the probes for use at any sensitivity which employs the particular Type 3A9 input attenuator used in steps b and c. When it is necessary to use a different input attenuator, steps b and c should be repeated for that attenuator. The input deflection factor group associated with each of the four attenuators is listed in Table 2-1.

TABLE 2-1

VOLTS/DIV	Attenuator
10 μ V to 10 mV	1X
20 mV to .1 V	10X
.2 V to 1 V	100X
2 V to 10 V	1000X

e. When examining a small differential signal in the presence of relatively large common-mode components, fine adjustment of probe CMRR may be made by temporarily connecting both probes to either of the two signal sources.

Movement of the probes should be kept to a minimum after the adjustment.

Current Probes

The following adjustment procedure is recommended when preparing to use Tektronix 125-turn current probes with the Type 3A9.

Set the Type 3A9 controls:

CURRENT-VOLTS	CURRENT
CURRENT/DIV	1 mA
VARIABLE	CAL
POSITION	Midrange
UPPER —3 dB FREQUENCY	.1 MHz
LOWER —3 dB FREQUENCY	DC
AC-GND-DC +INPUT	GND
AC-GND-DC —INPUT	GND
STEP ATTEN DC BAL	Adjusted for DC Balance

Set the Type 561B controls:

Calibrator	10 mA
Time Base	
Time/Div	.5 ms
Variable	Calib
Triggering	
Mode	Auto
Slope	+
Coupling	AC
Source	Int

a. Connect the current probe to the Type 3A9 AC CURRENT PROBE INPUT.

b. Connect the current probe to the 10 mA current test loop on the Type 561B front panel (if using a 560-Series instrument with no current test loop, use the Standard Amplitude Calibrator 5 mA current loop).

c. Position the display to place the top of the square wave to graticule center, using the POSITION control.

d. Adjust the Type 561B Focus and Intensity controls for a well-defined trace of normal viewing intensity.

e. Adjust the Type 3A9 L F COMP control for a square wave having a slope of 1% (1 minor division as shown in Fig. 2-6). If using the Standard Amplitude Calibrator 5 mA current test loop, adjust L F COMP for one-half of one minor division of slope.

See Fig. 2-7 for low frequency characteristics at various current levels.

SECTION 3

CIRCUIT DESCRIPTION

Change information, if any, affecting this section will be found at the rear of the manual.

Introduction

A block diagram description covering the general configuration of each circuit in the Type 3A9 is included in this section. Following the block diagram description is a detailed description of each circuit and the functions of specific components.

Simplified drawings are provided where necessary for easier circuit understanding. Complete schematic diagrams are included in the Diagrams sections. These should be referred to throughout the detailed circuit description.

The values of resistors on the schematics are in ohms unless otherwise specified. Capacitor values are indicated in the following manner unless otherwise specified; whole numbers indicate the value in pF, decimal numbers indicate the value in μF . For example, 33 is pF and 0.1 is μF .

BLOCK DIAGRAM DESCRIPTION (see Block Diagram Pullout preceding schematics)

Input Coupling

A signal applied to the + Input connector passes through the input coupling selector switch to the input attenuator circuit. The signals can be AC coupled, DC coupled or disconnected internally. When the Input coupling switch (see Input Amplifier diagram) is in the DC position, the input signal is coupled directly to the input attenuator. In the AC position, the AC signal is coupled through the coupling capacitor, blocking any DC component. The GND position disconnects the signal from the amplifier, connects the signal to ground through $1\text{ M}\Omega$ and grounds the input amplifier gate. This switching arrangement provides a ground reference for the amplifier without removing the input leads or otherwise disconnecting the input signal. The $1\text{ M}\Omega$ resistor allows the input capacitor to be pre-charged in the GND position. With the input capacitor charged to the DC level of the signal, there will be no charging current surge into the amplifier input when switching to the AC position.

The —INPUT function in the same manner as the +INPUT.

Current Probe Input

Signal from the current probe is fed into the $\times 16$ preamp through two paths (1) directly from the AC CURRENT-VOLTS switch to the +INPUT, and (2) via the PROBE COMP control, through the compensating feedback amplifier (integrator), through the AC CURRENT-VOLTS switch to the —INPUT.

When the AC CURRENT-VOLTS switch is in the VOLTS position, the probe signal is grounded.

The amplifier, Q370-Q375, an integrating feedback configuration, provides compensation for the probe characteristics to give essentially flat response to less than 10 Hz (dependent upon current probe type). Fig. 3-1 gives a straight-line approximation of probe and compensation characteristics and the resultant response.

Fig. 3-2 shows a simplified diagram of the amplifier.

Input Attenuators

The input attenuators for the + and — Inputs are of the conventional RC type and, with one exception, are identical. The exception is that the resistive elements of the — input attenuator are adjustable to facilitate matching the — and + inputs to obtain optimum DC common-mode signal rejection.

The attenuators (schematic diagram number 2) are frequency-compensated voltage dividers which provide constant attenuation at all frequencies within the passband of the instrument, while maintaining a constant input time constant ($47\ \mu\text{s}$) for all positions of the VOLTS/DIV switch.

Each attenuator contains an adjustable capacitor to provide correct attenuation at high frequencies and adjustable shunt capacitance to provide correct input capacitance. The attenuators, in conjunction with gain switching in the output amplifier, are used in only the 20 mV/DIV through 10 V/DIV. From 10 μV /DIV through 10 mV/DIV, only the output amplifier gain switching is used to set the deflection factor.

Preamp

From the input attenuators, the signal is coupled to the preamp. The preamp consists of two identical feedback amplifiers connected in a differential configuration. The overall differential gain is approximately 16.3.

The supply voltages for the two amplifiers are obtained from a common power supply which is bootstrapped to the input to improve the common-mode rejection ration of the preamp.

Each input is equipped with an overdrive protection circuit consisting of fuses and clamping diodes. For deflection factors from 10 μV /DIV through 10 mV/DIV the fuse will open if the current exceed 1/16 A (approximately 15 V at the input), preventing damage to the input circuitry.

An overdrive detector circuit is provided to indicate when the preamp is approaching the limits of its differential dynamic range. A front-panel indicating lamp lights when overdrive occurs.

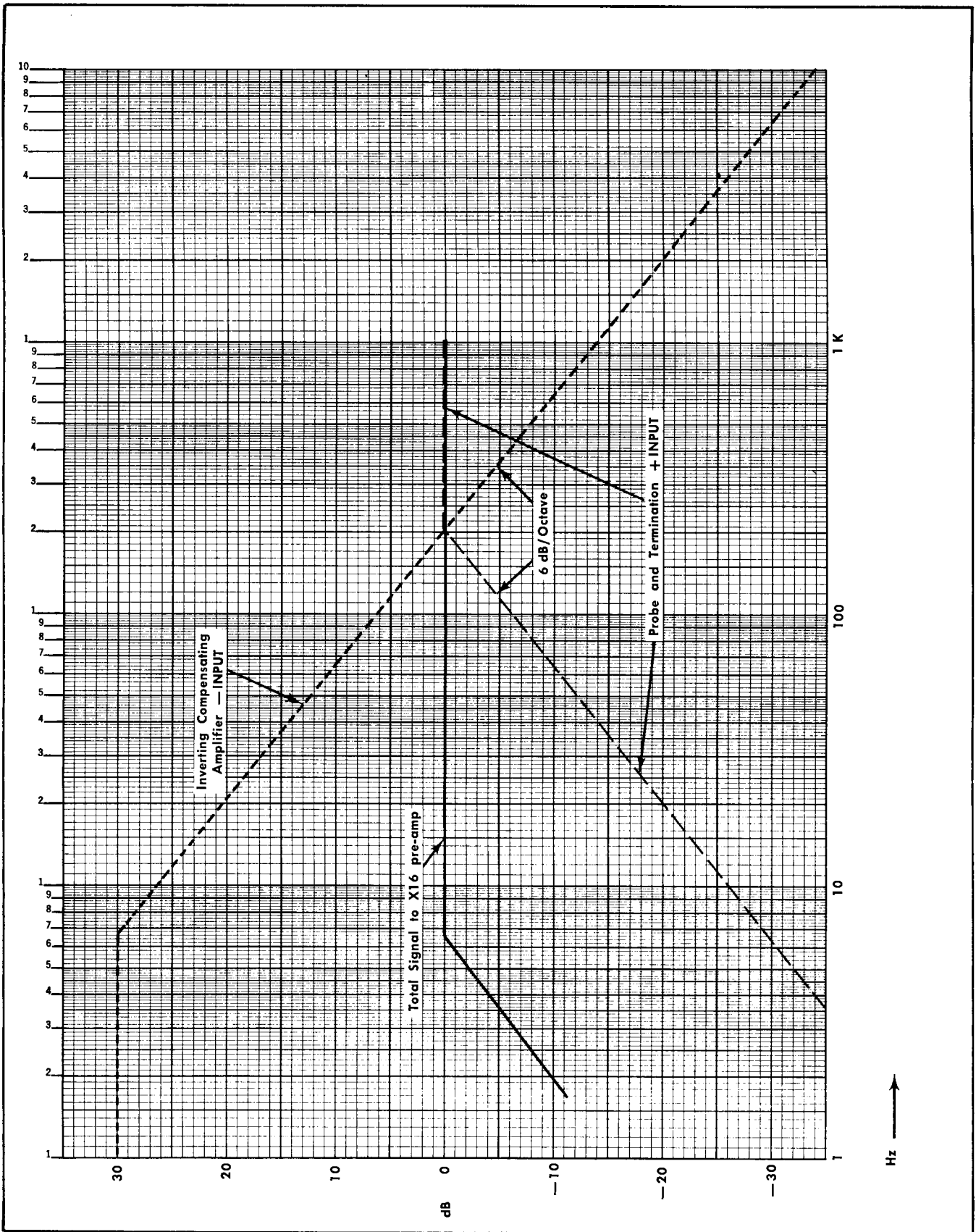

Fig. 3-1. Straight line approximation of probe and compensation characteristics.

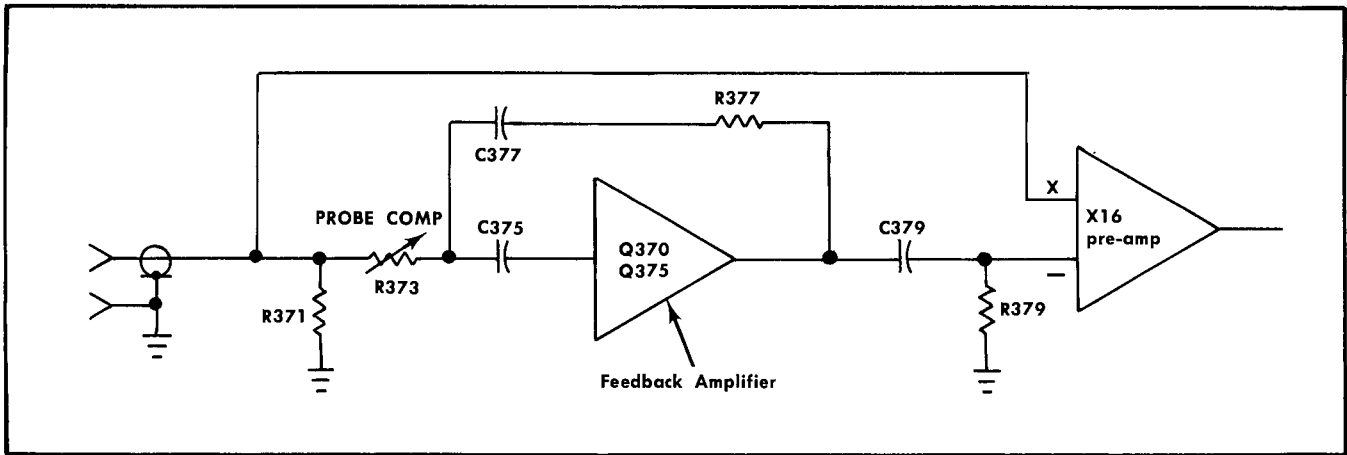

Fig. 3-2. Simplified diagram of the current probe amplifier.

When the LOWER —3dB FREQUENCY selector is in any position other than DC or DC OFFSET and the Input Coupling switch is in DC, there is no on-screen indication of the DC condition in the preamp. If the differential dynamic range of the amplifier is exceeded and the amplifier is driven into non-linearity or overdrive, an erroneous display is likely.

An offset generator is provided to balance out any currents in the preamp resulting from signals containing differential components. Offset (variable) allows the varying component to be amplified, and at the same time maintains the amplifier differential capabilities.

Low Frequency —3 dB Point

The push-pull output of the preamp is coupled through a LOWER —3 dB FREQUENCY selector. The selector switches the components of the coupling network in each half of the preamp to select the low frequency cutoff points (.1 Hz, 1 Hz, 10 Hz, 100 Hz, 1 kHz and 10 kHz). The DC position of the selector bypasses the low frequency selection circuitry and direct-couples the preamp to the Output Amplifier.

Output Amplifier

The signal from the LOWER —3 dB FREQUENCY selector is coupled to the gain-switching section of the Output Amplifier. This section of the Output Amplifier is a feedback amplifier similar to that of the preamp. The VOLTS/DIV switch changes the value of the common source resistor of the amplifier, thereby changing the gain.

The UPPER —3 dB FREQUENCY selector switches capacitance across the output of the Gain Switching Amplifier to set the high frequency —3 dB point through 9 frequencies; 100 Hz, 300 Hz, 1 kHz, 3 kHz, 10 kHz, 30 kHz, 100 kHz, 300 kHz and 1 MHz.

Positioning of the trace, and variable VOLTS/DIV, are provided in the stage following the UPPER —3dB FREQUENCY selector. A CALibrate switch and indicator lamp

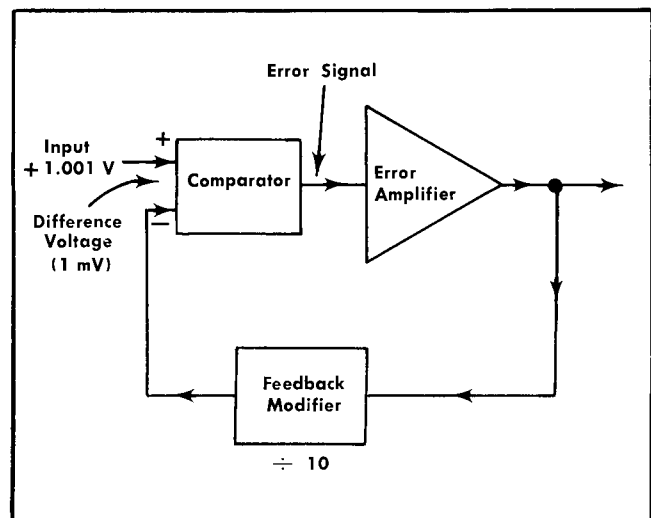

Fig. 3-3. Block representation of generalized feedback system.

are provided to show the CAL switch out of the CALibrated position.

Overall amplifier gain is adjusted in the feedback loop of the deflection amplifier.

A signal out (approximately 1.0 volt per displayed division, depending on the sensitivity of the main frame) jack is provided on the front panel with an internal adjustment to set the DC level.

BASIC FEEDBACK AMPLIFIERS

Since the 3A9 utilizes several multi-stage feedback amplifiers, a review of feedback systems is given.

Fig. 3-3 represents a generalized feedback system in which it is desired to produce an output signal accurately and stably related to the input.

The arrangement of Fig. 3-3 causes the modified output to be nearly equal to the input. Any difference between

Circuit Description—Type 3A9

these is detected by the comparator, which produces an error signal equal to the difference and applies this difference to the error amplifier, which in turn amplifies the error and feeds back a correction to reduce the original error.

The input to the modifier (the system output) is also accurately related to the system input, provided that the modifier is made up of stable components.

Assume an amplifier gain of 10,000 and a feedback modifier which is a 10:1 divider. If the amplifier output is 10 volts, the modifier output is 1 volt and the error signal (output divided by gain) is 1 mV. In this case, the difference between the desired output (10 times the 1.001 volt input) of 10.01 volts and the actual output of 10.00 volts is only 10 mV, or 1 part in 1000.

In practice the comparator and error amplifier are often combined in a differential amplifier.

A single-ended version of the basic configuration used in the Type 3A9 is illustrated in Fig. 3-4 with the basic blocks of Fig. 3-3 identified.

The comparator is FET Q1. Any departure in the gate-to-source bias voltage will cause a change in drain current, the change being applied as an error signal to the input of the error amplifier.

The error amplifier consists of grounded emitter stage Q₂, driving emitter follower Q₃. The internal output appears at the emitter of Q3 and is fed back to the comparator input by way of modifier (voltage divider) R₁, R₂.

For this amplifier, $V_o = (1 + \frac{R_2}{R_1}) V_{om}$, and since $V_{om} \cong V_i$, then the gain, $\frac{V_o}{V_i} \cong 1 + \frac{R_2}{R_1}$.

The useful output of the amplifier is the collector signal current i_o' . This current is nearly equal to the emitter current, i_o'' , which is flowing through R₁ (in addition to the relatively small error current from Q₃).

$V_{om} = i_o'' R_1$, and since $V_{om} \cong V_i$ and $i_o'' \cong i_o'$, then $i_o' \cong \frac{V_i}{R_1}$.

Thus, the output current vs. input voltage depends primarily on the gain setting resistor R₁.

A voltage output can also be obtained by passing i_o' through load resistor R₃. The overall voltage gain is, then, $\frac{V_o'}{V_i} \cong \frac{R_3}{R_1}$.

If the lower end (grounded end in Fig. 3-3) of R₁, instead of being returned to ground, is connected to the same point in another identical circuit, a differential feedback amplifier with push-pull output is the result (see Fig. 3-5).

DETAILED CIRCUIT DESCRIPTION

Input Coupling

Signals applied to the + and — input connectors may be AC coupled, direct (DC) coupled or internally disconnected (see Fig. 3-6).

When the +AC-GND-DC input coupling switch, SW201, in the DC position, the + input signal is coupled directly to the + input attenuators.

When the input switch is set to AC capacitor C202 is placed in the circuit to couple signals of approximately 1.6 Hz and higher to the attenuators. C202 blocks any DC component of the signal.

When the input switch is in the GND position, R201 and C201 present a load to the circuit under test that is similar to the load presented when the input switch is set to AC. The GND position also provides a ground reference to the input of the amplifier without the need to remove the applied signal from the input connector.

NOTE

When DC levels are to be blocked by AC coupling, the input switch should be set to GND while input connections are made or broken. This will permit the coupling capacitor to charge without damaging the input circuitry or overdriving the amplifier.

When the CURRENT-VOLTS switch is in the VOLTS position, the + and — inputs are connected to the input attenuators and the current signal is connected to ground. When in the CURRENT position, the current probe signal is connected to the input attenuators.

Input Attenuators

The input attenuators are conventional frequency-compensated voltage dividers. At DC and for low-frequency signals, the dividers are essentially resistive (attenuation ratio determined by the resistance ratio). At high frequencies, at which the capacitive reactance becomes effective, the attenuation ratio is determined by the impedance ratio.

In addition to providing constant attenuation at all frequencies within the bandwidth capabilities of the instrument, the input attenuators maintain a constant input RC characteristic (one megohm paralleled by 47 pF) for all settings of the VOLTS/DIV switch.

Input Protection

Input protection consists of fuses F131, F231 and diodes D132, D133, D232 and D233. If the signal should reach a level sufficient to forward-bias one of the protection diodes (greater than ±15.6 V), current will be drawn through that diode, protecting the input FET's. If that current should exceed 1/16 A, the protective fuse(s) will open. If the circuit under test is not able to supply enough current to open the fuse, damage to the circuit under test could result.

Gate Current Compensation

The leakage current associated with the gates of the input FET's may be as high as 100 pA. This 100 pA of leakage current (through 1 megohm to ground, R113 or R213) will produce an offset of 100 μV, which at high input sensitivities of not acceptable. To compensate this effect, the gates of the input FET's may be adjusted to zero volts by returning R113, R213 through variable controls R115 and R215 to a slightly negative supply voltage (see Fig. 3-7).

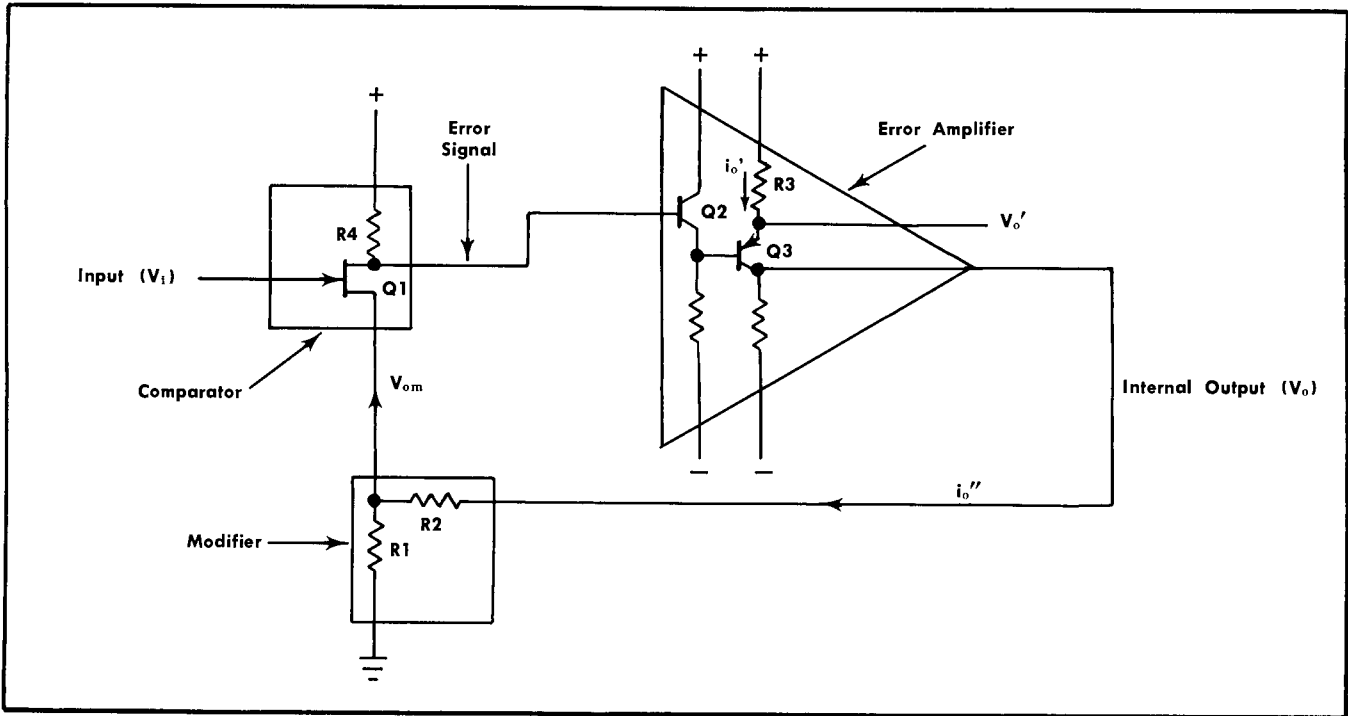

Fig. 3-4. Single-ended version of the basic configuration used in the Type 3A9.

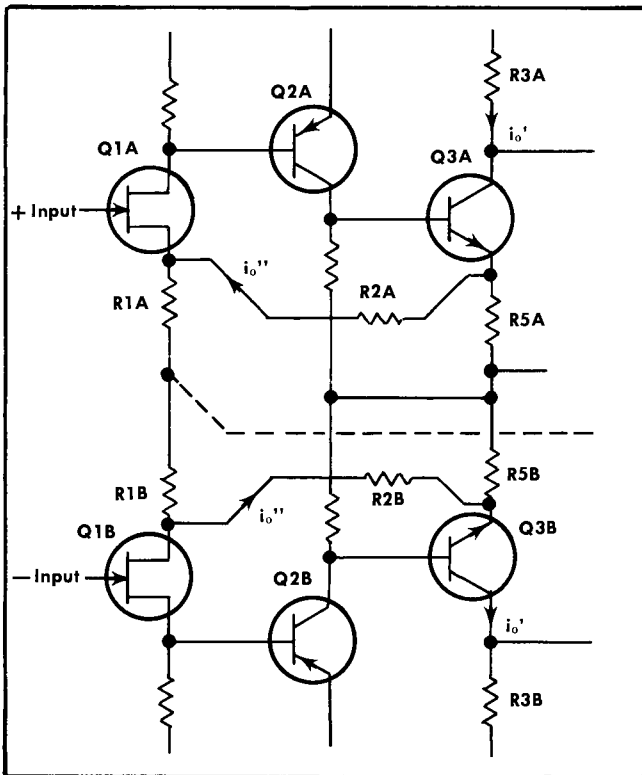

Fig. 3-5. Basic differential feedback amplifier.

Leakage current associated with the gates of the input FET's and the overload protection diodes increase rapidly with temperature, approximately doubling for every 10°C. To compensate this increase, a temperature-sensitive input current balancing network is included, using thermistors as the sensing elements.

As the voltage across R113 and R213 increases due to increase in temperature of the active devices, an equal voltage change is produced in the thermistor compensating circuit, maintaining the FET gate level at zero volts.

The gate current compensation becomes inoperative if the straps are removed for high input impedance operation.

Preamp

The feedback amplifiers in the + and - inputs are identical except for circuit numbers. Except where needed for clarification, only the amplifier in the + input will be described in detail.

Fig. 3-8 is a partial diagram of the input amplifier illustrating the current paths.

The feedback amplifier in the +input consists of Q133A, Q144A and Q254. The feedback path is from the source of Q254, through the divider (modifier) consisting of R253, R251. R251 is the gain setting resistor and since approximately the same signal current flows through both R251 and R257, the gain may be calculated by the ratio of these resistances, $R257/R251 (V_o/V_i)$.

Circuit Description—Type 3A9

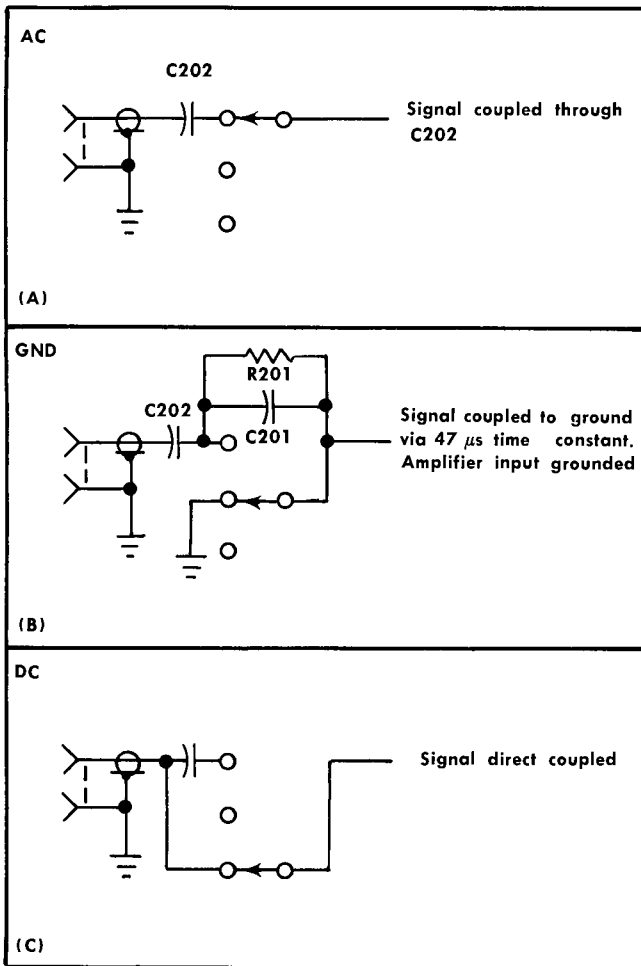

Fig. 3-6. Signal path for 3 positions of the input coupling switch.

Common-Mode Rejection

One of the primary functions of the preamp is to reject any common-mode component of the input signal and amplify only the difference.

Assume that the inputs are tied together and a voltage is applied to the common input. The amplifier differential output is ideally zero, and would actually be zero provided that the characteristics of all corresponding elements on the two sides of the amplifier were exactly matched (e.g., Q133A & B transconductance and μ , Q144A & B beta, current sources, etc.). In practice, any mismatch will cause a differential output.

Even with perfect matching there is still a common-mode output current, due to common-mode gain, which results in an undesirable common-mode signal applied to the subsequent stages of the amplifier.

A floating power supply minimizes these common-mode difficulties and therefore improves the common-mode rejection. (Fig. 3-9).

The input to the bootstrap ($\times 1$ gain) amplifier is connected to the junction of R151, R251. The bootstrap amplifier consists of an emitter follower, Q283, and its +8, +17 and -13 V supplies are generated by a chain of Zener diode shunt regulators, D275, D285, and D295. Current for

the $\times 16$ preamp and the Zener diodes is supplied by two current sources, Q284 and Q294. The collector impedance or these current sources presents minimum loading to Q283 output and maintains the gain of the $\times 1$ amplifier (bootstrap efficiency) very close to 1.

The entire power supply and amplifier move an amount equal to the common-mode voltage, and no changes occur in voltage or current level as a result of common-mode voltage except at Q154, Q254 drains.

Zeners D355, D352 and D347 provide regulated -15 and -30 volts.

Q295 diverts current away from Q326, the Offset generator current source, in the event of failure of the +125 volt supply. Without this protection, if the +125 volt supply is slow in rising, (or fails) current could be forced to flow out the FET gate circuit, through the Type 3A9 input. To prevent this condition, if the +125 volts supply fails, Q295 base goes negative to the point at which Q295 saturates, providing a low impedance path to divert current from Q326.

D297 protects Q295 from reverse breakdown.

High Frequency Common-Mode Rejection

At higher frequencies stray capacitance to ground at various points in the $\times 16$ preamp begins to inject significant current into the amplifier as a result of common-mode signals. Differential capacitor C162, connected from the floating power supply to the output lines, injects adjustable current into the output to equalize the net output current resulting from high frequency common-mode signals, and extends the frequency range over which good CMRR can be obtained to approximately 100 kHz.

Input Cross-Neutralization

The use of a common bootstrap supply results in an undesirable capacitive coupling between the two inputs. Consider the effect of applying +1 volt to the +input while keeping the -input at 0 volts (grounded). See Fig. 3-10.

The results are: (a) an output current, as shown in Fig. 3-10 and (b) a shift of all floating supply voltages (and several other voltage levels) by 0.5 volt, due to the divider action of R151, R251. The drain of Q133B also rises and injects a current, i_b , through the drain-to-gate capacitance of Q133_b and into the -input. If there is any impedance between the -input and ground, i_b will develop a voltage which will be applied to the -input. This voltage subtracts from the original +input and causes an erroneous output.

The -amplifier signal output current i_o flows through R153, and causes its lower end to go negative. An adjustable capacitor, C131, connected from Q154 source to the -input can be adjusted to divert current, i_b away from the input and so neutralize the effect of C_{dg} .

C231 and R231 perform a similar function for the +input.

DC OFFSET

The purpose of the DC Offset system is to buck out small DC components of the input signal, allowing the amplifier to

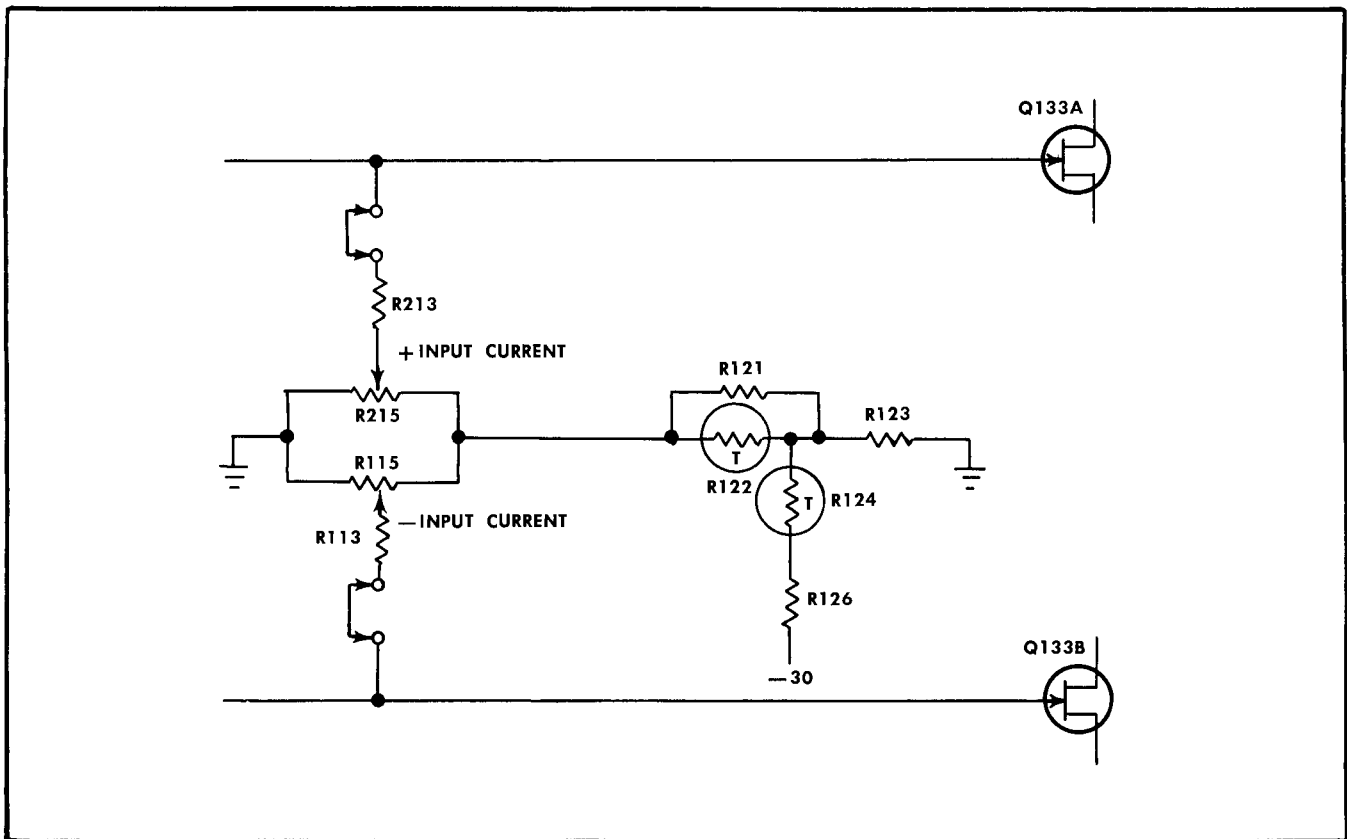

Fig. 3-7. Gate current compensating circuit.

amplify only the varying components while maintaining the differential capabilities.

When a DC signal is applied across the inputs, the resultant output currents are balanced out as described below (see Fig. 3-11). Fig. 3-11A shows the currents for zero input. If a DC signal is applied to the +input, a current will flow in R251, R257, producing an output. If this current can be supplied by the offset generator as shown in Fig. 3-11B, the current in Q254, Q154 does not change and no output is produced. In this manner the DC component of the signal may be offset (up to ± 1 volt) and the full differential capabilities of the amplifier realized.

The offset generator produces a balanced offset current for use in the $\times 16$ preamp. Due to the wide range of the offset system (200,000 cm at $10 \mu\text{V}/\text{DIV}$) stable components are used, and circuit techniques are employed which minimize drift and noise.

In the reference voltage generator the DC OFFSET COARSE and FINE potentiometers tap an adjustable portion of the voltage across the reference Zener, D352. Voltage divider R341, R347 and R345 supplies a fixed 50% of the differential signal applied to the current generator. The voltage is adjustable over -4 V to $+4\text{ V}$ (approx). See Fig. 3-12.

This adjustable reference voltage is applied to the input of a pair of coupled feedback amplifiers (similar in concept to the $\times 16$ preamp).

The feedback amplifiers A and B are composed of Q314A, Q334 and Q314B, Q324, respectively, with the

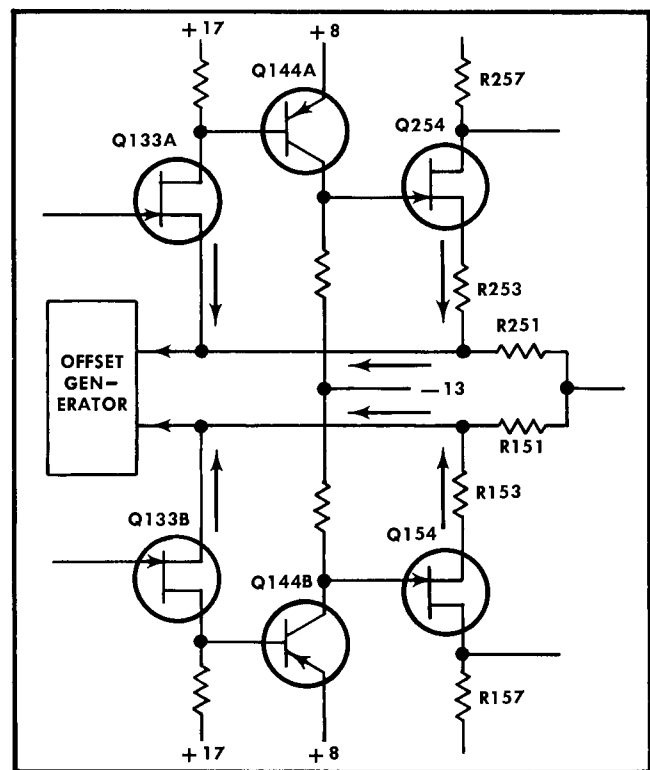

Fig. 3-8. Partial schematic of the input amplifier showing current paths.

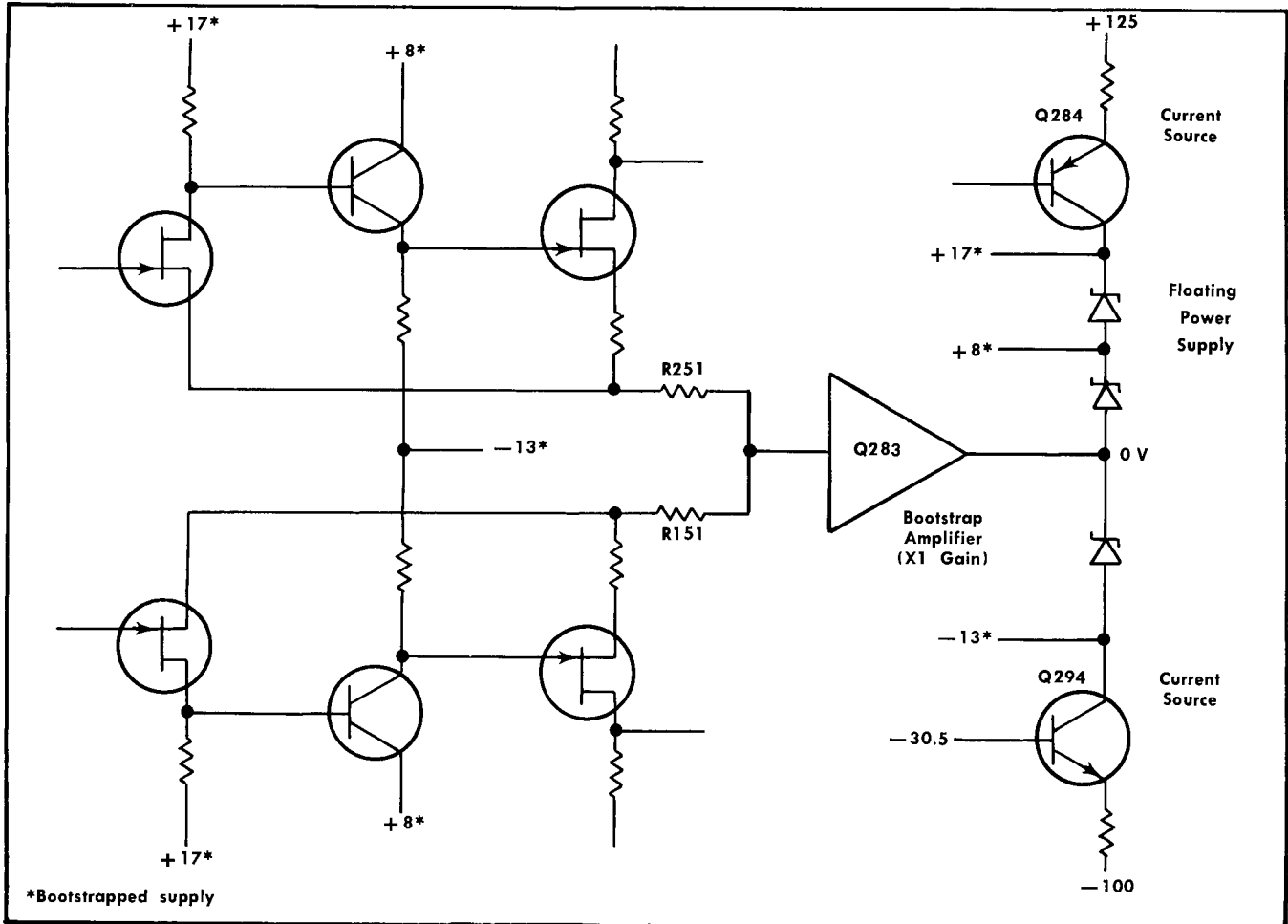

Fig. 3-9. Input amplifier with bootstrapped power supply.

reference input applied to the emitters of dual transistor Q314 and the feedback to its bases. Current source Q326 supplies operating current for the amplifiers. See the preamp schematic at the back of the manual. In amplifier A (Fig. 3-12) the feedback action forces the $-$ input voltage (also the output voltage) V_{2a} , to follow the $+$ input, V_{1a} , and similarly V_{2b} follows V_{1b} . The differential input, $(V_{1b} - V_{1a})$ is therefore reproduced across resistors R331, R321 as $(V_{2b} - V_{2a})$ and the resultant current i_{offset} , $\frac{V_{2b} - V_{2a}}{R_{321} + R_{331}}$, flows through the FET output stages of amplifiers Q324 and Q334, and out the FET drains to the $\times 16$ preamp.

When the offset is not in use, V_{1b} is switched to the fixed divider.

V_{1a} is adjustable over a small range with respect to V_{1b} by the COARSE DC BAL control, to adjust out any initial DC unbalance in the $\times 16$ preamp to bring its output to zero with zero input.

The FINE offset control moves the voltage at both ends of the COARSE control via divider R351, R352, R353, R354 by varying the voltage at the junction of R352 and R353.

Capacitor C336 filters Zener noise from the reference voltage.

LOWER -3 dB FREQUENCY SELECTOR

This switch selects the lower -3 dB Frequency of the amplifier and has a range of 0.1 Hz to 10 kHz in decade steps. Selection is accomplished by switching the resistor and capacitor of a pair of AC couplings, one in each side of the amplifier, between the $\times 16$ preamp and the gain-switched amplifier. See Fig. 3-13. For 100 Hz to 10 kHz, C258 is used, and resistors R276, R277 and R279 are switched to the output in the following combination:

-3 dB Freq	100 Hz	1 kHz	10 kHz
Resistors	R279	R276-R279	R277-R279

Whenever R276 or R277 is not on the output side of C258 the resistance (R276 or R277) is placed across the input, to keep the high frequency load resistance seen by i_{in} constant.

C276 is switched across C258 for the lower three ranges, 0.1 Hz, 1 Hz and 10 Hz. C258 is shorted out for DC coupling.

Resistor R256 adds a small increment in gain, when C258 is used to compensate for the loss of gain through the capacitive divider formed by C258 and stray capacitance C_s .

Gain Switching Amplifier

The gain switching amplifier is a balanced differential configuration very similar to the $\times 16$ preamp, with a fixed power supply.

Gain is changed by switching values of R408.

Diode D422 prevents reverse breakdown in Q424 under overdrive conditions. D420 limits the voltage at the base of Q434 and prevents base-emitter breakdown in the following stage.

R405, AC Atten Bal, in series with the source of Q404A develops a small adjustable voltage which is used to set the voltage across the gain-setting resistors, R407 and R408, to zero when the gate-to-gate voltage of Q404 is zero.

Zener D415 provides a stable emitter supply voltage for Q414, and C415 filters out Zener noise. R421 maintains proper Zener current.

C414 and C514 prevent high frequency oscillations.

The Var Bal control, R425, sets the voltage across the VAR control to zero, with zero input signal, to prevent trace deflection as the VAR control is rotated throughout its range.

UPPER —3 dB FREQUENCY Selector

Switch 175B, UPPER —3 dB FREQUENCY Selector, switches capacitors across the output of Q424, Q524 to set the high frequency response characteristics.

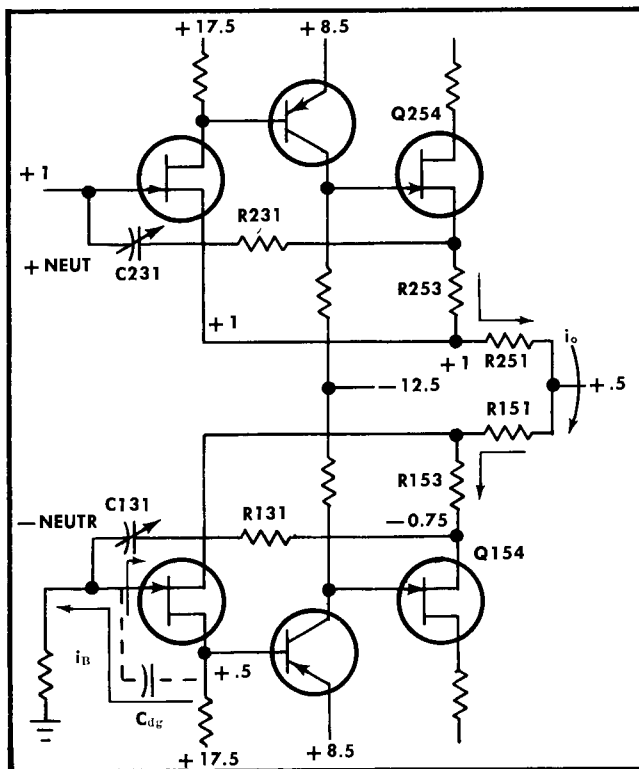

Fig. 3-10. Input amplifier showing effects of capacitive coupling through C_{dg} and resulting current, i_o .

Position and Variable Stage

Position control R440 feeds adjustable current into the emitters of Q434, Q534 by way of R437, R537. This current mixes with signal current developed in the emitter resistors, R431-R433, R531-R533 and R535 and flows out of the collectors to provide vertical beam deflection.

Variable control (VAR) R535 provides emitter degeneration, the gain being determined by the total emitter feedback resistance. Gain is adjustable over a 2.5:1 ratio, and provides a fine control to interpolate between the steps of the VOLTS/DIV switch.

An indicator lamp (UNCAL) lights whenever the VAR switch is out of the CAL position.

Output Stage

The output amplifier, Q444-Q544, Q454-Q554, is a feedback amplifier with the feedback path from Q454 collector through R445-R545 and the adjustable feedback divider R443, R447, R543, R547 and R450, to the bases of Q444-Q544.

D444, D445 prevent the base-to-base signal to Q444-Q544 from exceeding 0.6 volts, ensuring a fast overdrive recovery of the output amplifier.

Overall gain of the Type 3A9 can be adjusted to match the main frame in which it is used by adjusting GAIN control R450. R450 provides a variable current diverting path in the feedback.

Diodes D563, D565 and D567 provide operating voltages, +15 V, +35 V and +50 V to various points throughout the Type 3A9. The capacitors in this Zener-regulated supply provide filtering.

Trigger and Signal Out Amplifiers

A signal is picked off at Q454 collector and fed to a FET source follower. The FET source provides a low impedance point from which trigger signal is fed to the time base. The trigger signal amplitude at Q464 source is approximately 3.75 volts per division of display.

Signal is also fed to the base of an emitter follower, Q474, to provide signal access at the front-panel SIG OUT jack.

R471 and R473 divide the signal to give approximately 1.0 volt per division of display at the front-panel SIG OUT jack.

R467, Sig Out DC Level, sets the DC level at the SIG OUT jack to zero volts.

C461, Sig Out HF Comp, compensates the voltage divider, R461, R465, R467, to provide good frequency response at the SIG OUT jack.

Input Overdrive Indicator

When the LOWER —3 dB FREQUENCY selector is in any position other than DC or DC OFFSET and the input coupling switch is in DC, there is no on-screen indication of the DC conditions in the $\times 16$ preamp. The amplifier may be driven into non-linearity or overload by a DC component which could result in an erroneous display.

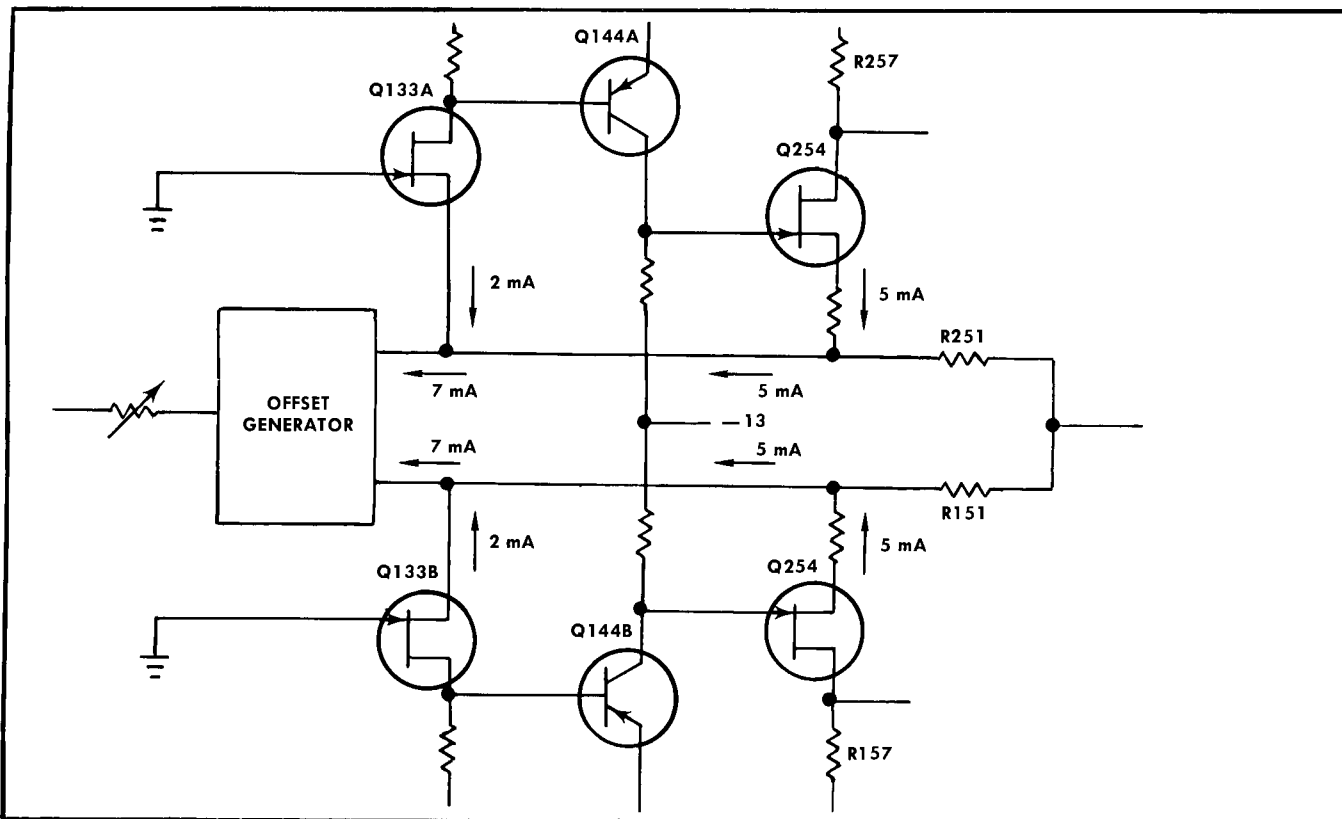

Fig. 3-11A. Conditions with zero offset voltage, showing balanced currents.

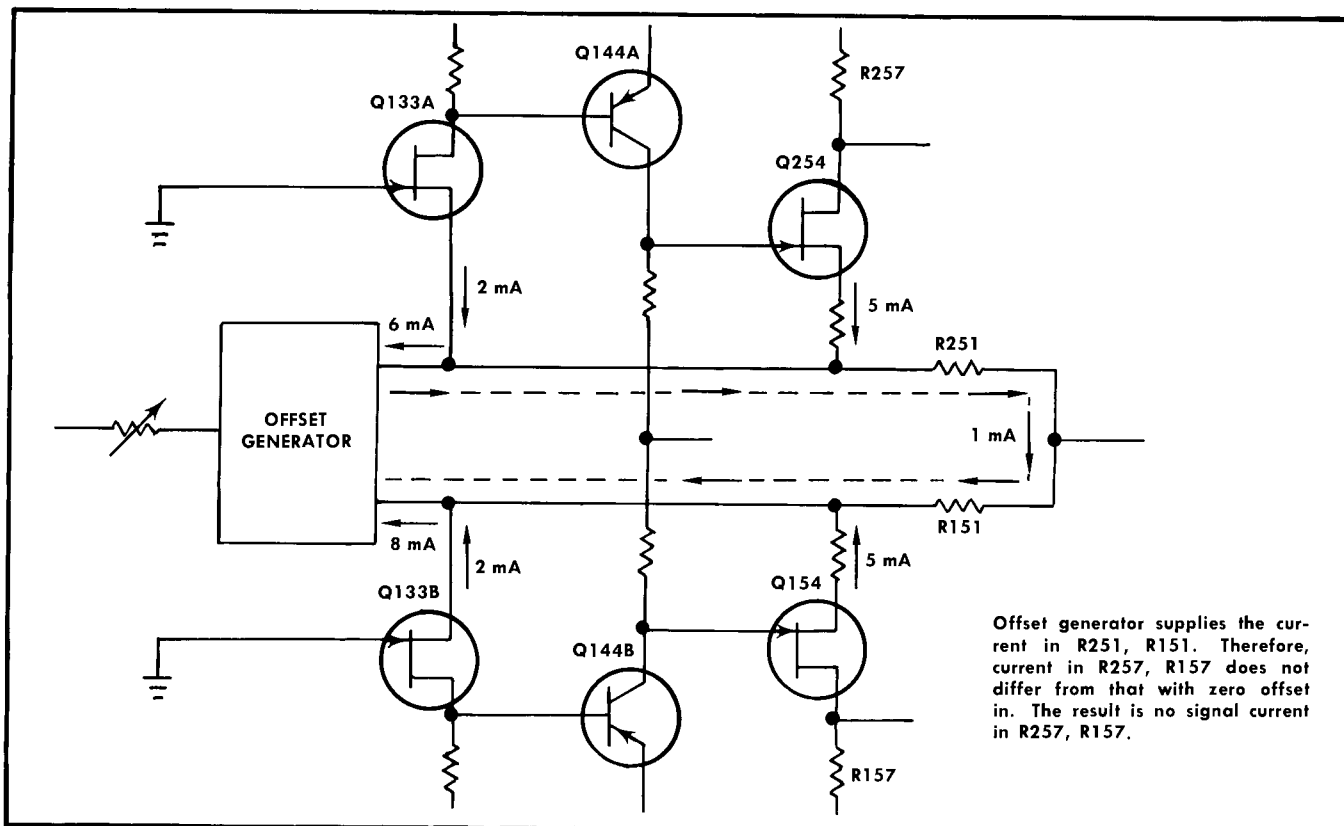

Fig. 3-11B. Conditions with offset to produce 1 mA through R251, R151.

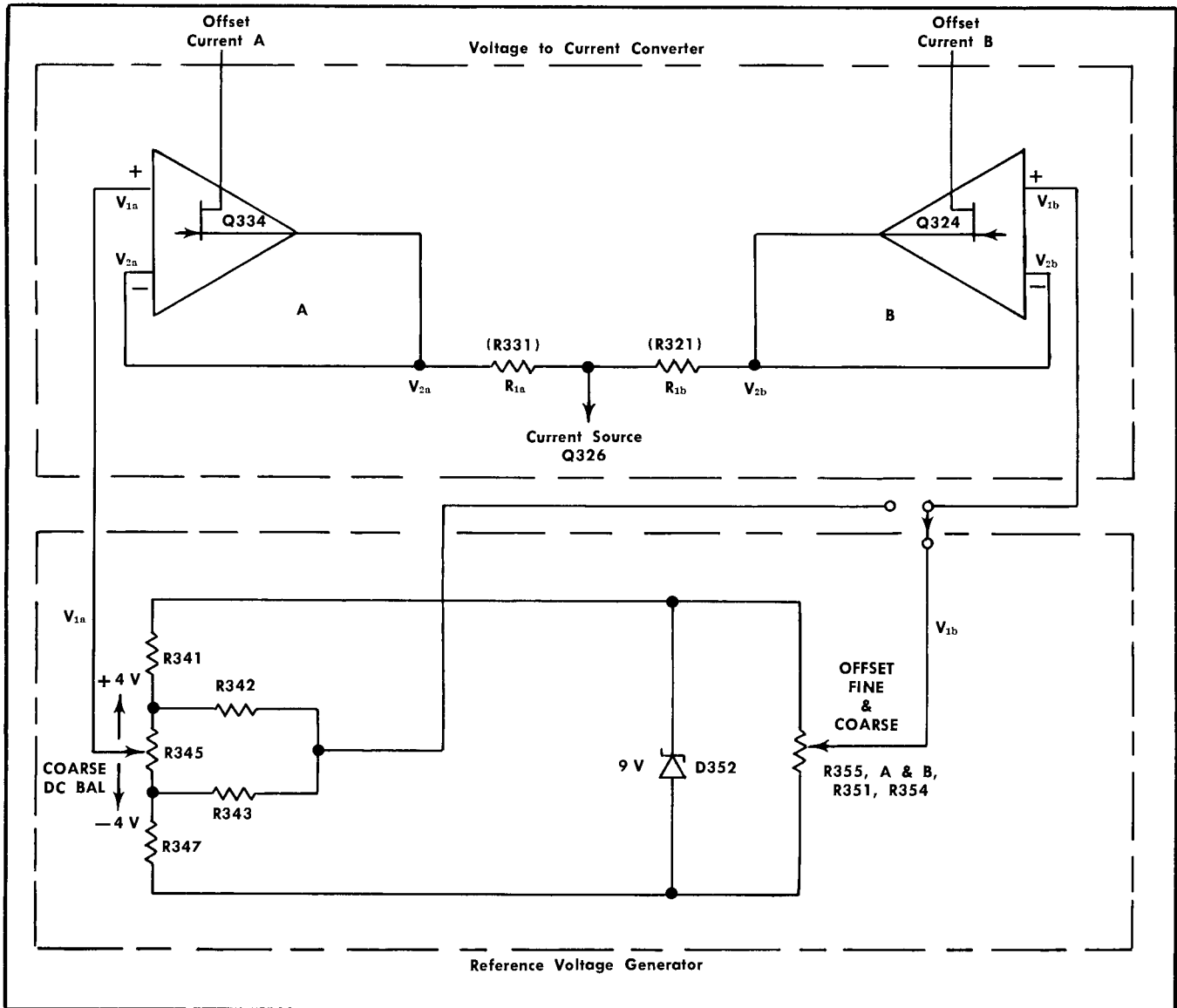

Fig. 3-12. Simplified offset voltage generator.

The input overdrive lamp indicates that the $\times 16$ preamp is approaching the limits of its differential dynamic range.

The indicator circuit functions as follows: When the amplifier is operating normally (no overdrive condition), D162 and D262 are reverse biased, Q163 is biased off and Q164 is saturated. Current in R172 (with Q164 saturated) sets the voltage across B174 below the firing potential and B174 is extinguished.

If the voltage on either of the output lines (anodes of D162 or D262) exceeds the voltage at the emitter of Q163 by approximately 1 volt, D162 or D262 turns on, biasing Q163 into conduction, turning off Q164, allowing the voltage across B174 to reach the firing point.

C164 and R164 allow the lamp to indicate on overdrive pulses of short duty cycle. C164 charges through Q163, R171 and R172. When Q163 turns off, C164 discharges

slowly through R164, holding B174 on long enough to be seen, or until the next pulse.

R171 and R174 equalize the firing transients on the two leads of the neon, B174, reducing radiation into the physically close input circuitry.

Current Probe Amplifier

Probe signal is fed directly into the preamp +input when CURRENT-VOLTS selector switch is in the CURRENT position. The input signal is also fed to the integrating feedback amplifier which compensates for the undesirable low frequency probe characteristics. This compensated signal is then fed to the preamp -input.

R373, PROBE COMP, provides adjustable compensation for the various current probe types and for variations in probe inductance for any given type.

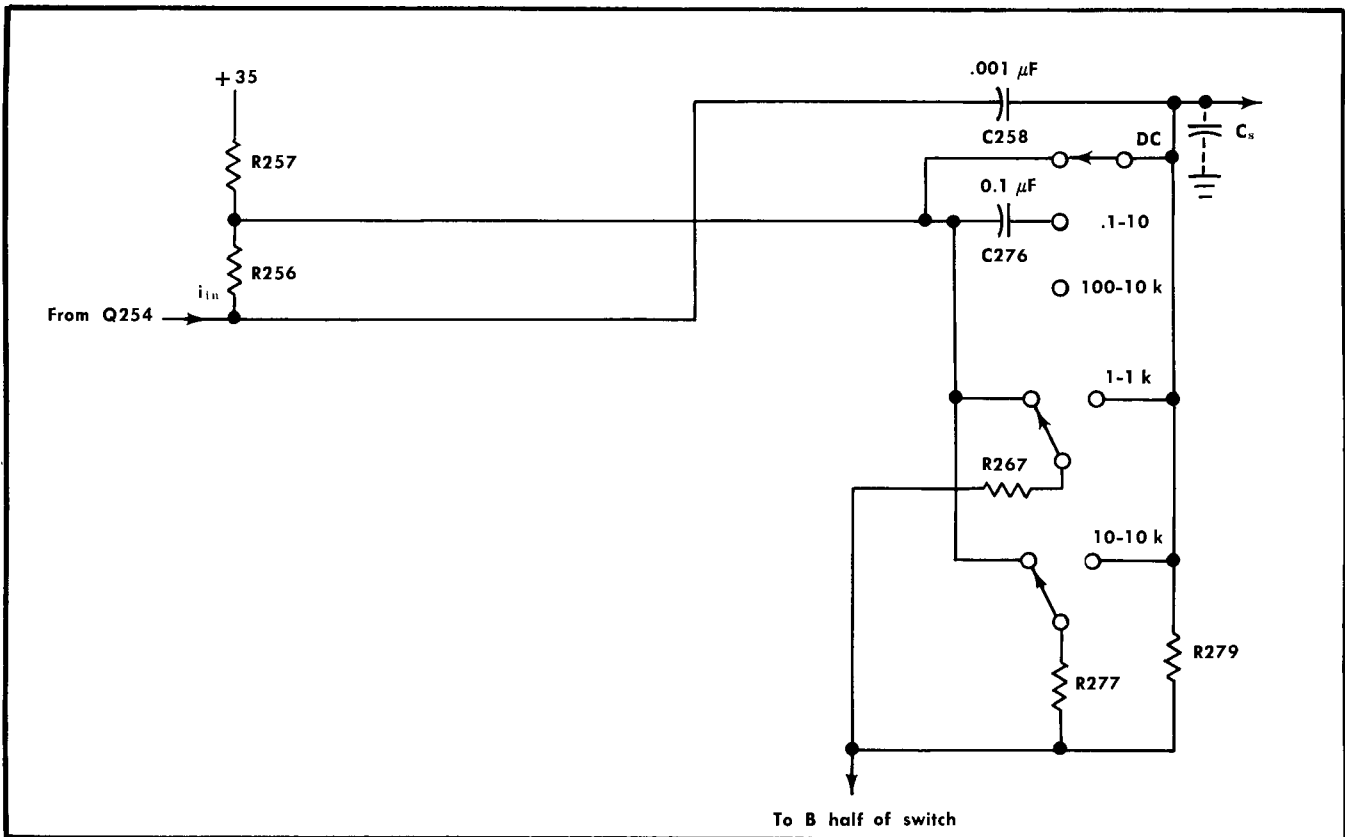

Fig. 3-13. Simplified LOWER -3 dB FREQUENCY selector.

R377, in series with the feedback capacitor C377, compensates for the variations of input resistance as R373 is adjusted, and keeps the high-frequency deflection factor correct.

C379, R379 is an AC coupling which blocks the DC level (at the output of the feedback amplifier) from the $\times 16$ pre-amp.

R371 provides the proper load for the probe.

R383, R385, R387, R391 set the operating parameters of the amplifier.

R389, C383 are high frequency parasitic oscillation suppressors.

C375 is a DC blocking capacitor.

SECTION 4

MAINTENANCE

Change information, if any, affecting this section will be found at the rear of the manual.

PREVENTIVE MAINTENANCE

General

Preventive maintenance consists of cleaning, visual inspection, lubrication and recalibration. Preventive maintenance performed on a regular basis will help prevent failure of the unit and will improve its reliability.

Cleaning the Front Panel

Loose dust may be removed with a soft cloth and/or a dry paint brush. Water and mild detergent such as Kelite or Spray White may be used.

CAUTION

Avoid the use of chemical agents which might damage the plastics used in this unit. Avoid chemicals such as benzene, toluene, xylene, acetone or similar solvents.

Cleaning the Interior

Cleaning the interior of the unit should precede calibration, since the cleaning process could alter the settings of the calibration adjustments.

To clean the interior, use low-velocity compressed air to blow off the accumulated dust. Very high velocity air streams should be avoided to prevent damage to some of the components. Hardened dirt can be removed with a soft, dry paint brush, cotton-tipped swab or cloth dampened with a water and mild detergent solution. Avoid the use of chemical cleaning agents that might damage the plastic parts.

Lubrication

The reliability of potentiometers, rotary switches and other moving parts can be increased if they are kept properly lubricated. Use a cleaning-type lubricant on shaft bushings, interconnecting plug contacts and switch contacts. Lubricate switch detents with a heavier grease. A lubrication kit containing the necessary lubricating materials and instructions is available through any Tektronix Field Office. Order Tektronix part number 003-0342-00.

Visual Inspection

The unit should be inspected occasionally for such defects as poor connections, broken or damaged circuit boards, improperly seated transistors and heat-damaged parts. The remedy for most visible defects is obvious.

But, damage from overheating is usually a symptom of less obvious trouble and unless the cause is determined before parts are replaced, the damage may be repeated.

Transistor Checks

Periodic preventive maintenance checks on the transistors used in the unit are not recommended. The circuits within the unit generally provide the most satisfactory means of checking transistor operation. Performance of the circuits is thoroughly checked during recalibration, and sub-standard transistors will usually be detected at that time.

Recalibration

To insure accurate measurements, the Type 3A9 calibration should be checked after each 1000 hours of operation or every six months if used intermittently. Complete calibration instructions are contained in Section 5.

The calibration procedure can be helpful in isolating major troubles in the unit. Moreover, minor troubles not apparent during regular operation may be revealed and corrected during calibration.

CORRECTIVE MAINTENANCE

General

Replacement of some parts in the unit should be done by following a definite procedure. Some procedures, such as soldering and replacing components on the circuit boards, are outlined in this portion of the manual.

Many electrical components are mounted in a particular way to reduce or control stray capacitance and inductance. When selecting replacement parts, it is important to remember that the physical size and shape of a component may affect its performance at high frequencies. When a repair is made, calibration of that portion of the circuit should be checked. Refer to the Performance Check/Calibration procedure in Section 5 and perform the applicable calibration steps.

Obtaining Replacement Parts

Standard Parts. All electrical and mechanical part replacements for the Type 3A9 can be obtained through your local Tektronix Field Office or representative. However, many of the standard electronic components can be obtained locally in less time than is required to order them from Tektronix, Inc. Before purchasing or ordering replacements parts, check the parts lists for value, tolerance, rating, and description.

NOTE

When selecting replacement parts, it is important to remember that the physical size and shape of the component may affect its performance in the instrument, particularly at high frequencies. All replacement parts should be direct replacements unless it is known that a different component will not adversely affect instrument performance.

Special Parts

Some parts are manufactured or selected by Tektronix to satisfy particular requirements, or are manufactured for Tektronix to our specifications. These and most mechanical parts should be ordered through your Tektronix Field Engineer or Field Office. See Parts Ordering Information and Special Notes and Symbols on the page immediately preceding Section 6.

Soldering Techniques

Circuit Boards. Use ordinary 60/40 solder and a 35- to 40-watt pencil-type soldering iron on the circuit boards. The tip of the iron should be clean and properly tinned for best heat transfer to the solder joint. A higher wattage soldering iron may separate the wiring from the base material.

The following technique should be used to replace a component on the circuit board. Most components can be replaced without removing the board from the unit.

1. Grip the component lead with long-nose pliers. Touch the soldering iron tip to the lead at the solder connection. Do not touch the soldering iron tip directly to the board as it may damage the board.

2. When the solder begins to melt, pull the lead out gently. This should leave a clean hole in the board. If the hole in the board is not open after the component lead has been pulled free, reheat the solder and clean the hole with a vacuum desoldering tool, a toothpick or other pointed object.

3. Bend the leads of the new component to fit the holes in the board. Cut the leads of the new component to the same length as those of the old component. Insert the leads into the board until the component is firmly seated against the board, or as positioned originally. If it does not seat properly, heat the joint and gently press the component into place.

4. Apply the iron and a small amount of solder to the connection to make a firm solder joint. To protect heat-sensitive components, hold the lead between the component body and the solder joint with a pair of long-nose pliers or other heat sink.

5. Clip the excess lead that protrudes through the board.

6. Clean the area around the soldered connection with flux-remover solvent to maintain good environmental characteristics and appearance. Be careful not to remove information printed on the board.

Metal Terminals. When soldering metal terminals (e.g., interconnecting plug pins, switch terminals, potentiometers, etc.), ordinary 60/40 solder can be used. The solder-

ing iron should have a 40- to 75-watt rating with a $\frac{1}{8}$ inch wide chisel-shaped tip.

Observe the following precautions when soldering to metal terminals:

1. Apply heat only long enough to make the solder flow freely.

2. Apply only enough solder to form a solid connection; excess solder may impair the function of the part.

3. If a wire extends beyond the solder joint, clip the excess wire close to the joint.

4. Clean the flux from the solder joint with a flux-remover solvent to maintain good environmental characteristics and appearance.

Removing or Replacing Circuit Boards

In general, the circuit boards used in the Type 3A9 need never be removed unless they must be replaced. Electrical connections to the boards are made by two methods: soldered lead connections and solderless pin connectors.

To remove or replace a board, proceed as follows:

1. Disconnect all leads connected to the board. Observe the soldering precautions given earlier in this section.

2. Remove all the screws holding the board to the chassis or other mounting surface.

3. Lift the circuit board out of the unit. Do not force or bend the board.

4. Clean the flux from the solder joint with a flux-remover. As a guide, correct connections of the wires are shown in Figs. 4-5 and 4-6. When reconnecting the pin connectors, use care in mating the pins so the connectors are not damaged or enlarged.

Removing and Replacing Switches

If either of the AC-GND-DC switches is defective, remove and replace the switch. Use normal care in disconnecting and reconnecting the leads (to gain access to the DC-GND-DC switches, remove the shields). The switches can be replaced without removing the front-panel overlay. First, remove the nuts and lockwashers from the switch, then remove the switch.

Single wafers on the VOLTS/DIV and -3 dB FREQUENCY switches are not normally replaced. If any of these switches is defective, the entire switch should be replaced. The switches can be ordered through your Tektronix Field Engineer either unwired or wired, as desired. Refer to the Electrical Parts List to find the unwired and wired switch part numbers.

CAUTION

When disconnecting or connecting leads to a wafer-type switch, do not let solder flow around and beyond the rivet on the switch terminal. Excessive solder can destroy the spring tension of the contact.

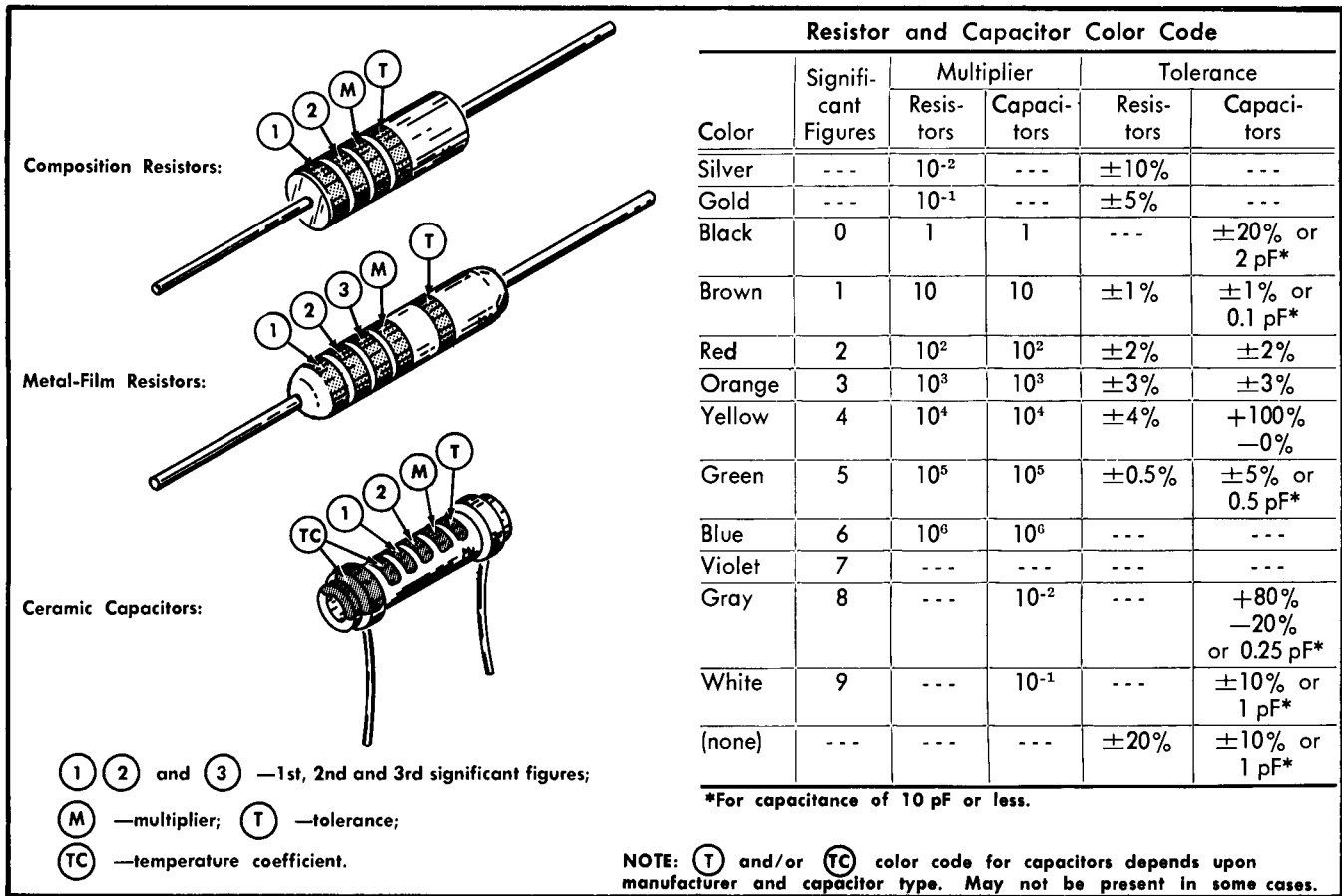

Fig. 4-1. Color code for resistors and ceramic capacitors.

Fuse Replacement

The fuses in the + and - inputs are located on the amplifier circuit board and are 1/16 A fast blow. Spare fuses are located on the chassis behind the front-panel POSITION control.

CAUTION

The particular types and makes of fuse listed in the Parts List have been selected for performance under conditions not normally specified by fuse manufacturers. Other apparently equivalent types may not perform satisfactorily.

TROUBLESHOOTING

Introduction

The following information is provided to facilitate troubleshooting of the Type 3A9. Information contained in other sections of this manual should be used along with the following information to aid in locating the defective components. An understanding of the circuit operation is very helpful in locating troubles. See the Circuit Description section for complete information.

Troubleshooting Aids

Diagrams. Circuit diagrams are given on foldout pages in Section 8. The component number and electrical value of each component in this instrument are shown on the diagrams. Each main circuit is assigned a series of component numbers. Important voltages are also shown on the diagrams. The portions of the circuit mounted on circuit boards are enclosed with a blue line.

Switch Wafer Identification. Switch wafers shown on the circuit diagrams are coded to indicate the physical location of the wafer on the actual switch. The number portion of the code refers to the wafer number of the switch assembly. Wafers are numbered from the first wafer behind the driven end of the shaft to the last wafer.

The letters F and R indicate whether the front or rear of the wafer is used to perform the particular switching function. For example, 2R of the UPPER -3 dB FREQUENCY switch is the second wafer when counting from the driven end. The letter R refers to the rear side of the wafer.

Wiring Color Code. All insulated wires used in the Type 3A9 are color-coded according to the EIA standard color code (as used for resistors) to facilitate circuit tracing. The widest color stripe identifies the first color of the code.

Power-supply voltages can be identified by three color stripes and the following background color code; white,

Maintenance—Type 3A9

positive voltage; tan, negative voltage; gray, unregulated voltage.

Table 4-1 shows the wiring color code for the power-supply voltages using insulated wires for interconnection in the Type 3A9.

TABLE 4-1

Supply	Back-ground Color	1st stripe	2nd stripe	3rd stripe
+300 V	White	Orange	Brown	Brown
+125 V	White	Brown	Red	Brown
-100 V	Tan	Brown	Black	Brown

The remainder of the wiring in the Type 3A9 is color coded with two or less stripes, or has a solid background with no stripes. The color code helps to trace a wire from one point to another in the unit.

Resistor Color Code. Stable metal-film resistors used in this instrument may be identified by their light blue or gray body. If a metal-film resistor has a value indicated by three significant figures and a multiplier, it will be color coded according to the EIA standard resistor color code. If the resistor has a value indicated by four significant figures and a multiplier, the value will be printed on the body of the resistor. For example, a 333 k Ω resistor will be color coded, but a 333.5 k Ω resistor will have its value printed on the resistor body. The color code sequence is shown in Fig. 4-1.

Composition resistors are color coded according to the EIA standard color code.

Capacitor Markings. The capacitance values of common disc capacitors and small electrolytics are marked in microfarads on the side of the component body. The white ceramic capacitors used in the Type 3A9 are color coded in picofarads using a modified EIA code (see Fig. 4-1).

Diode Color Code. The cathode end of each glass-encased diode is indicated by a stripe, a series of stripes or a dot. For most silicon or germanium diodes with a series of stripes (the first stripe either blue or pink) the color code indicates the three significant figures of the Tektronix Part Number using the resistor color code system. Example: a diode color coded blue-brown-gray-green indicates a diode having Tektronix part number 152-0185-00. See Fig. 4-2. The cathode and anode ends of metal-cased diodes can be identified by the diode symbol marked on the body.

Transistor Lead Configuration. Fig. 4-3 show the lead configuration of the transistors used in this instrument. The tops of the sockets and the bottom views of the transistors are illustrated.

Circuit Boards. Figs. 4-4, 4-5 and 4-6 show the circuit boards used in the Type 3A9. Each electrical component on the boards is identified by its circuit number. The circuit boards are outlined with a blue line on the diagrams. The photographs of the boards used along with the diagrams will aid in locating the components mounted on the circuit boards and checking interconnecting wiring to the boards.

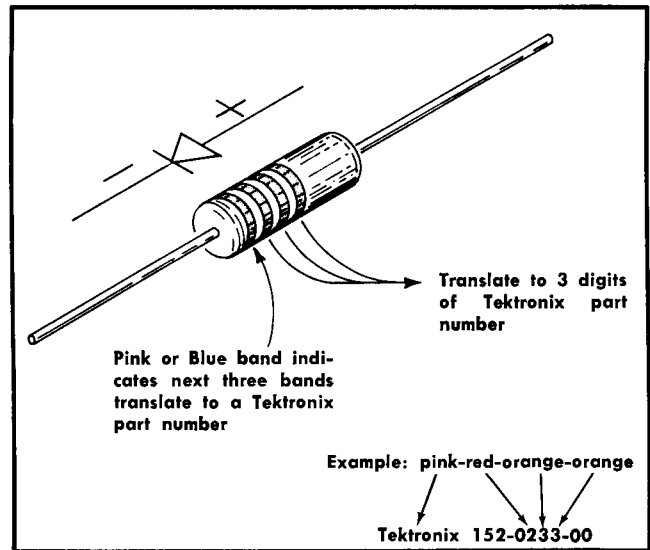

Fig. 4-2. Color code for diodes having Tektronix part number.

Test Equipment

Following is a list of test equipment which may be helpful when troubleshooting the Type 3A9.

1. Tektronix Type 575 Transistor Curve Tracer.
2. Voltohmmeter with 20,000 ohms/volt DC sensitivity. The test prods should be suitable for use in tight places to avoid accidental shorting of the circuits under test.
3. Test Oscilloscope having a bandwidth of DC to 1 MHz or better, calibrated deflection factor to 5 mV/div and differential input.
4. Two 1 \times probes for use with the Test Oscilloscope.
5. Plug-in extension cable, Tektronix part number 012-0038-00. (Permits operating the Type 3A9 outside of the plug-in compartment for better accessibility.)
6. Two coaxial cables with BNC connectors.
7. Adapter, T, BNC male to 2 BNC female.
8. Miscellaneous transistors and diodes.

Troubleshooting Techniques

This troubleshooting procedure is arranged in an order which checks the simple trouble possibilities before proceeding with extensive troubleshooting. The first few checks assure proper connections, operation and calibration. If the trouble is not located by these checks, the remaining steps aid in locating the defective component. When the defective component is located, it should be replaced following the replacement procedures given under Corrective Maintenance.

1. Check control settings. Incorrect control settings can indicate a trouble that does not exist. If there is any question about the correct function or operation of any control, see the Operating Instructions section.

2. Check Associated Equipment. Before proceeding with troubleshooting of the Type 3A9, determine that the equipment used with it is operating correctly. Check for properly connected signal and power source cables.

3. Visual Check. Visually check the portion of the instrument in which the trouble is located. Many troubles can be located by visual indications such as unsoldered connections, broken wires, damaged circuit boards, damaged components, etc.

4. Check Instrument Calibration. Check the calibration of the instrument, or the affected circuit if the trouble exists in one circuit. The apparent trouble may only be a result of misadjustment or may be corrected by calibration. Complete calibration instructions are given in the Performance Check/Calibration section of this manual.

5. Isolate Trouble to a Circuit. To isolate trouble to a circuit, note the trouble symptom. The symptom often identifies the circuit in which the trouble is located.

6. Check Circuit Board Interconnections. After the trouble has been isolated to a particular circuit, check the pin connectors on the circuit boards for correct connections. Figs. 4-4 and 4-6 show the correct connections for each board.

7. Check Voltages. Often the defective component can be located by checking for the correct voltage in the circuit. Typical voltages are given on the diagrams.

NOTE

Voltages shown on the diagrams are not absolute and may vary slightly between instruments. To obtain operating conditions similar to those used to take these readings, see the first page of the diagrams.

8. Check Individual Components. The following procedures describe the methods of checking individual components in the Type 3A9. Components which are soldered in

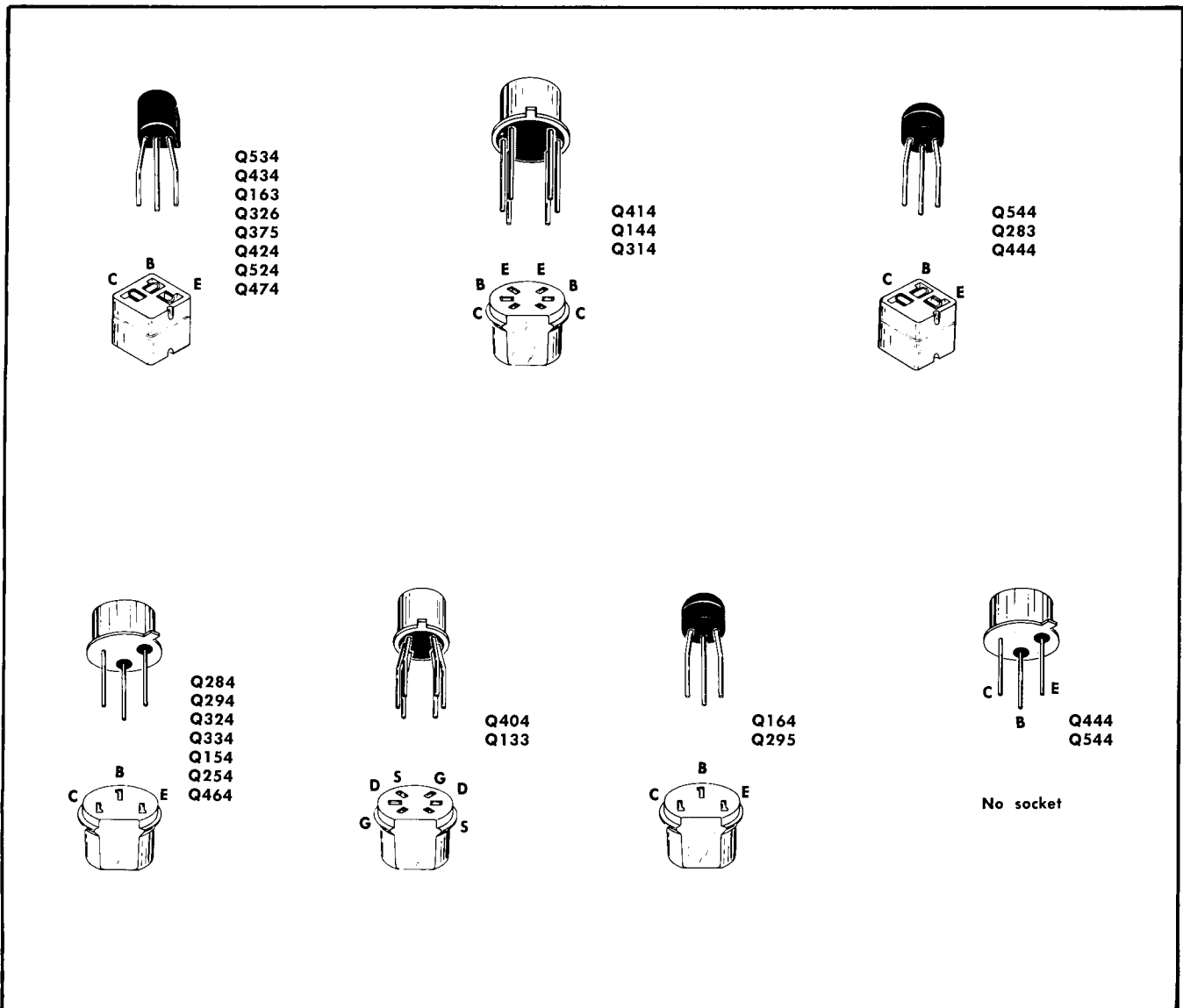

Fig. 4-3. Transistor lead configuration.

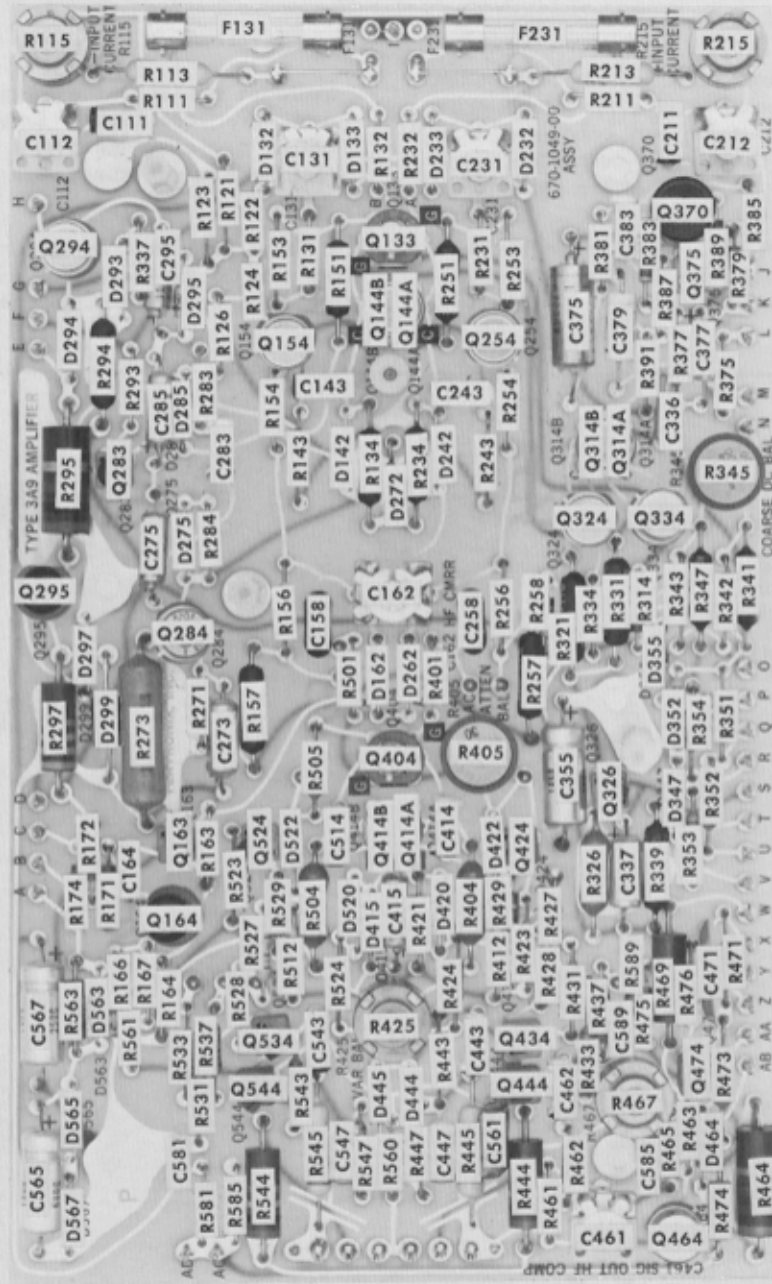

Fig. 4-4. Amplifier circuit board (components).

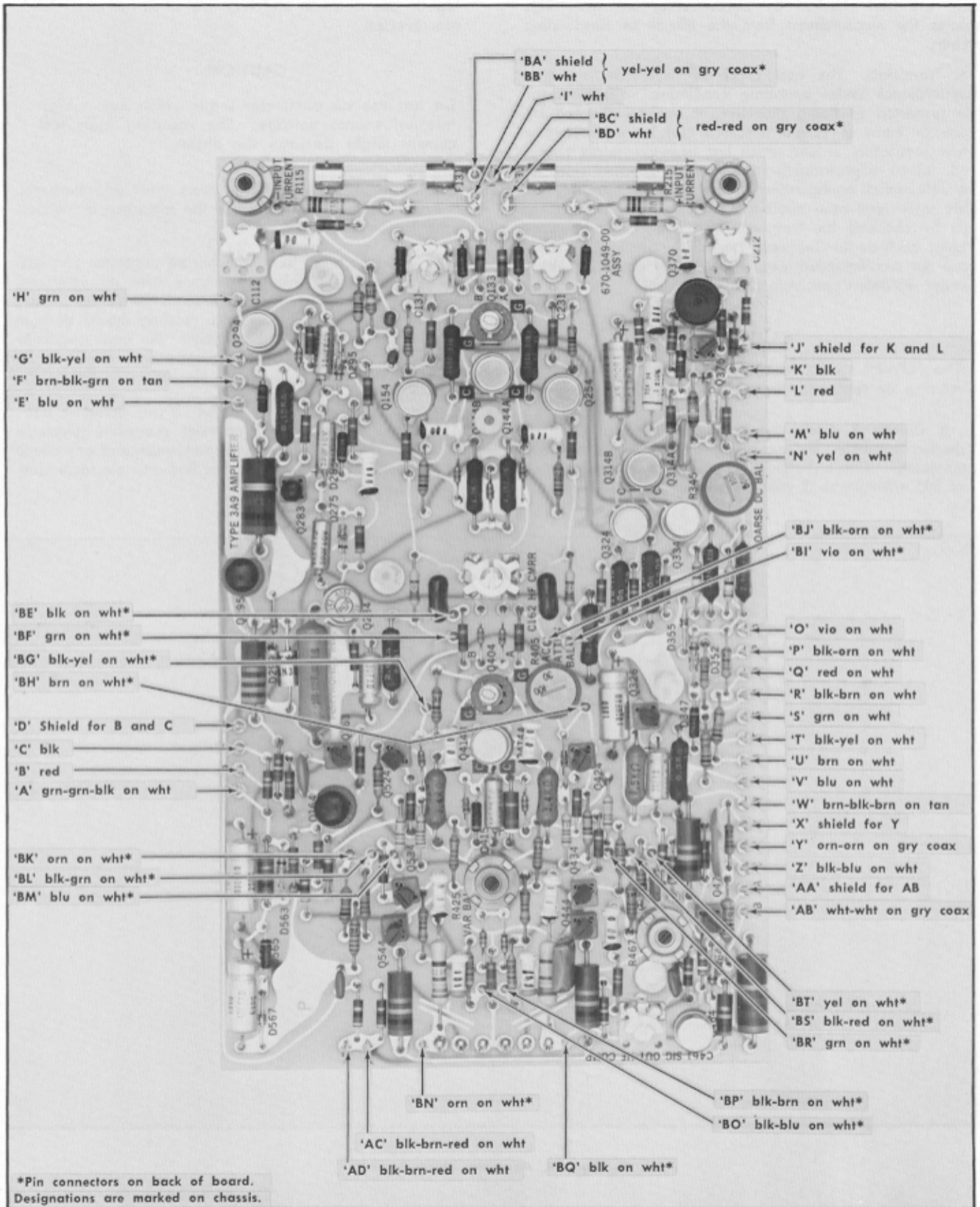

Fig. 4-5. Amplifier circuit board (wire color code).

Maintenance—Type 3A9

place are best checked by disconnecting one end. This isolates the measurement from the effects of surrounding circuitry.

A. Transistors. The best check of transistors is actual performance under operating conditions. If a transistor is suspected of being defective, it can be checked by one or more of several methods: (a) by substituting a new component or one which has been previously checked, (b) by interchanging transistors in opposite sides of a differential configuration or substituting transistors of the same type from another section of the instrument, or (c) by checking the transistor with a dynamic transistor tester (such as the Tektronix Type 575). Static-type testers are not recommended since they do not check operation under simulated operating conditions.

CAUTION

The POWER switch must be turned off before removing or replacing transistors.

B. Diodes. A diode can be checked for an open or shorted condition by measuring the resistance between terminals. With an ohmmeter using an internal source of 800 millivolts to 3 volts, the resistance should be very

high in one direction and very low when the meter leads are reversed.

CAUTION

Do not use an ohmmeter scale which has a high internal source voltage. The resulting high test current might damage the diode.

C. Resistors. Check the resistors with an ohmmeter. See the Electrical Parts List for the tolerance of resistors used in this instrument.

D. Capacitors. A leaky or shorted capacitor can best be detected by checking resistance with an ohmmeter on the highest scale. Do not exceed the voltage rating of the capacitor. The resistance reading should be high after initial charge of the capacitor. An open capacitor can best be checked with a capacitance meter or by checking its ability to pass AC signals.

9. Repair and Readjust the Circuit. If any defective parts are located, follow the replacement procedure given in this section. Be sure to check the performance of any circuit that has been repaired or that has had any electrical components replaced.

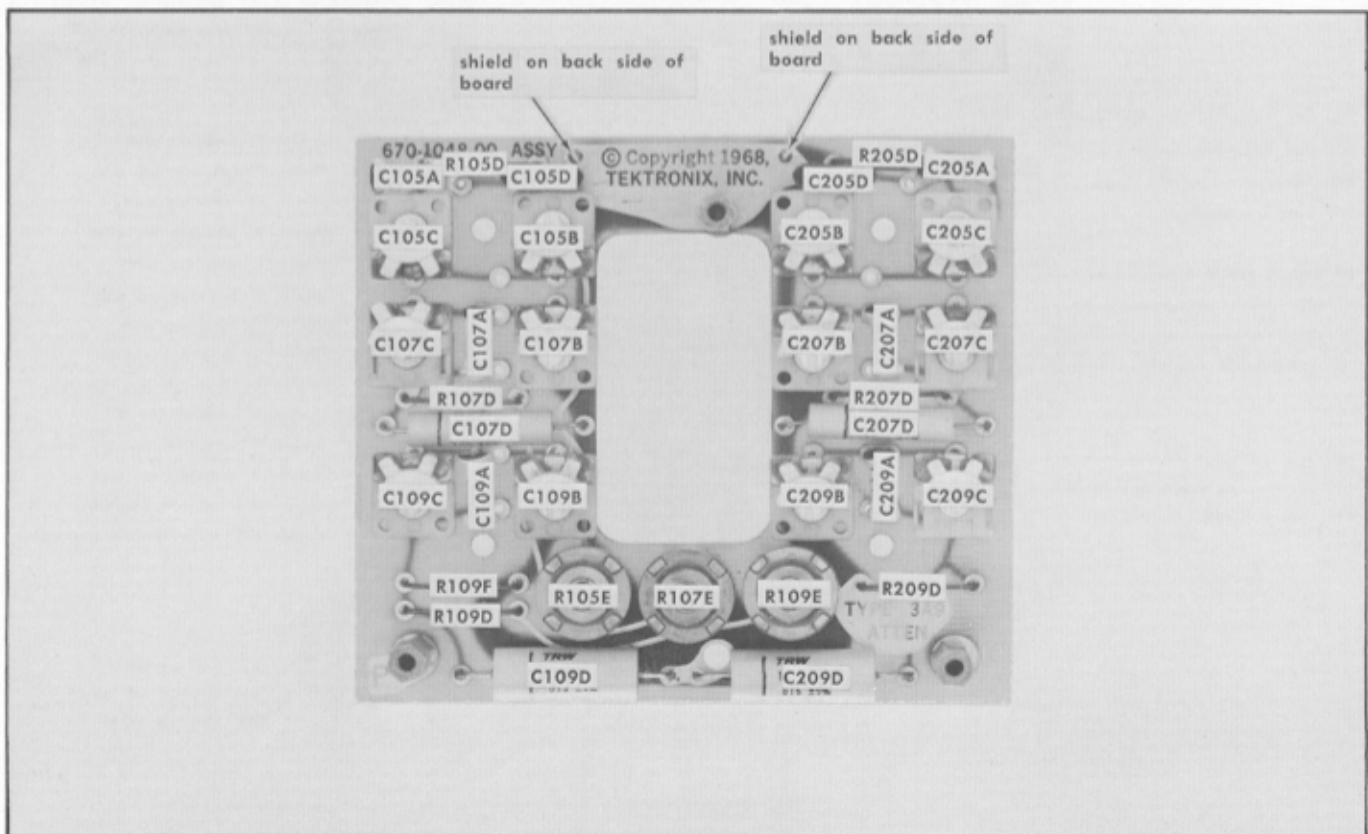

Fig. 4-6. Attenuator Circuit Board.

SECTION 5

PERFORMANCE CHECK / CALIBRATION

Change information, if any, affecting this section will be found at the rear of the manual.

Introduction

Complete information for accomplishing a Performance Check or Calibration of the Type 3A9 is contained in this section of the manual. The Equipment Required list is needed for either a Performance Check or for calibrating the Type 3A9. All waveform photographs, equipment setup pictures, and control settings apply whether the instrument is being calibrated or checked for performance.

To conduct a Performance Check, complete all the parts of each step in the following procedure, except the part subtitled ADJUST. To check the performance of the Type 3A9 it is not necessary to make any internal adjustments. Adjustments located on the front panel of the Type 3A9 can be performed when checking the performance of the instrument. If the instrument does not meet the performance requirements given in this procedure, the complete procedure including adjustments should be done. All performance requirements given in this section correspond to the characteristics given in Section 1 of this manual. For convenience in calibrating the Type 3A9, steps containing internal adjustments are marked with the symbol **Ⓐ**.

Calibration of the Type 3A9 requires completion of all parts of each step in the following procedure, including internal adjustments. Completion of all steps in this procedure returns the Type 3A9 to its original performance standards. To assure accurate measurements and correct operation, the calibration of the Type 3A9 should be checked after each 1000 hours of operation, or every six months if used infrequently. Before performing a complete calibration, thoroughly clean and inspect the instrument as outlined in the Maintenance section.

TEST EQUIPMENT REQUIRED

General

The following test equipment and accessories or their equivalent, are required for a complete performance check or calibration of the Type 3A9. Specifications given are the minimum necessary for accurate performance of this instrument. All test equipment is assumed to be correctly calibrated and operating within the given specifications. If equipment is substituted, it must meet or exceed the specifications of the recommended equipment.

For the quickest and most accurate calibration or performance check, special Tektronix calibration fixtures are used where necessary. These special calibration fixtures are available from Tektronix, Inc. Order by part number through your local Tektronix Field Office or representative.

1. 560 Series oscilloscope, referred to as the Indicator oscilloscope in this procedure. For this procedure a Type 561B was used.

2. Test Oscilloscope. Bandwidth, DC to 10 MHz or better; minimum deflection factor, 50 mV/DIV. Tektronix Type 547 with Type 1A2 plug-in is recommended.

3. Sine-Wave Generator. Output frequencies of 10 Hz through 1.5 MHz; output amplitude range from 2 V to 20 V, peak to peak.

4. Constant Amplitude Signal Generator. Frequency range, 50 kHz to 1.3 MHz sine wave; Amplitude, 5 mV to 2 V; Tektronix Type 191 is recommended.

5. Standard Amplitude Calibrator. Amplitude accuracy, within 0.25%; signal amplitude 0.5 mV to 100 V; output signal 1 kHz square wave and + and - DC levels. Tektronix Calibration Fixture 067-0502-00 is recommended.

6. Coaxial Cable. Impedance, 50 Ω ; length, 42 inches; connectors, BNC. Two each, Tektronix part number 012-0057-00 is recommended.

7. Dual Input Cable. Provides matched signal paths to both Type 3A9 input connectors. Tektronix part number 057-0525-00.

8. Variable Attenuator. A variable attenuator which has the end terminals of a 100-ohm potentiometer connected from input to ground and the potentiometer divider arm connected to the attenuator output. Tektronix Calibration Fixture 067-0511-00 is recommended.

9. 1000:1 divider. Tektronix part number 067-0529-00.

10. Input RC Normalizer. RC time constant, 47 μ s (1 M Ω -47 pF); connectors, BNC. Tektronix part number 067-0541-00 is recommended.

11. Attenuator. Ratio, 10:1; impedance 50 Ω ; connectors, BNC. Two each, Tektronix part number 011-0059-00.

12. Termination. Impedance, 50 Ω ; connectors, BNC. Tektronix part number 011-0049-00 is recommended.

13. Adapter. BNC to binding post. Tektronix part number 013-0094-00.

14. Adapter. BNC male to two female (T). Tektronix part number 103-0030-00.

15. Adapter. GR to BNC female. Tektronix part number 017-0063-00.

16. Adapter. GR to BNC male. Tektronix part number 017-0064-00.

17. High Frequency Current Test Fixture. Tektronix part number 067-0559-00.

18. Plug-in extension for the 560-series oscilloscopes (for calibration only). Tektronix part number 013-0034-00.

19. Screwdriver. Low capacitance (for calibration only). Tektronix part number 003-0001-00 or equivalent.

SHORT-FORM PROCEDURE

Type _____ Serial Number _____

Calibration Date _____

Calibrated by _____

1. Check or Adjust AC Atten Bal (R405) (Page 5-4)
Trace must remain within 1.5 graticule divisions while rotating the VOLTS/DIV switch from 10 mV to 20 μ V.
2. Check or Adjust Variable Bal (R425) (Page 5-4)
No trace shift while rotating the VARIABLE through-out its range.
3. Check or Adjust Coarse DC Bal (R345) (Page 5-4)
At 10 mV/DIV, trace should be within 0.1 div of graticule with VARIABLE at CAL and LOWER -3 dB FREQUENCY at DC. At 50 μ V, trace should be on-screen. If not, readjust R435.
4. Check or Adjust Gain (R435, front panel) (Page 5-6)
With 5 mV peak-to-peak signal in, display should be exactly 5 divisions, with VOLTS/DIV at 1 mV.
5. Check Variable Control Ratio (front panel) (Page 5-6)
Display Amplitude decreases by factor of 2.5 when VARIABLE is rotated fully counterclockwise.
6. Check VOLTS/DIV Gain Switch (Page 5-6)
Correct vertical deflection, 10 μ V through 10 mV.
7. Check or Adjust + Input Zero (R215) (Page 5-8)
Max trace shift, ± 2 divisions, switching +AC-GND-DC between GND and AC.
8. Check or Adjust $-$ Input Zero (R115) (Page 5-8)
Max trace shift, ± 2 divisions, switching $-$ AC-GND-DC switch between GND and AC.
9. Check DC Offset Range (Page 5-9)
Trace returns within calibrated graticule area with 1 volt of offset applied to the input.
10. Check Overdrive Recovery Time (Page 5-11)
Trace must return to within 5 mV of zero volts after 1 second overdrive is removed.
11. Check Input Overdrive Indicator (Page 5-13)
Input Overdrive indication must occur between 0.75 and 1.0 volt.
12. Adjust Cross Neutralization (C131) (Page 5-14)
Adjust for minimum aberration on lower leading corner of second cycle.
13. Adjust Cross Neutralization (C231) (Page 5-15)
Adjust for minimum aberration on lower leading corner of second cycle.
14. Check or Adjust C212 ($\times 1$, $-$ INPUT Attenuator Time Constant) (Page 5-16)
15. Check or Adjust C112 ($\times 1$, $-$ INPUT Attenuator Time Constant) (Page 5-17)
16. Check Input Attenuator Accuracy (Page 5-18)
Correction deflection factors, 10 mV through 10 V.
17. Check or Adjust Input Attenuator Differential Balance (R105, R107 and R109) (Page 5-20)
Optimum differential balance (minimum deflection amplitude)
18. Check Differential Dynamic Range (Page 5-22)
No change in sine wave amplitude when applying a DC level to the opposite Input.
19. Check or Adjust + Input Attenuator Compensation (C105C, C107C, C109C, C109B, C107B, C105B) (Page 5-23)
Optimum square wave response for all VOLTS/DIV switch positions.
20. Check or Adjust Input Attenuator Series Compensation (C205C, C207C, C209C) (Page 5-26)
21. Check or Adjust $-$ Input Attenuator Shunt Compensation (C205B, C207B, C209B) (Page 5-28)
Optimum flat bottom on square wave.
22. Check 100 Hz CMRR (Page 5-30)
Vertical tilt not to exceed 2 divisions (CMRR 100, 000:1 or greater).
23. Check AC Coupled CMRR at 60 Hz (Page 5-31)
Vertical deflection of display not to exceed 1 division. CMRR 2000:1 or higher.
24. Check or Adjust 100 kHz, Check 1 kHz CMRR (Page 5-31)
Vertical deflection not to exceed 2 divisions (.1 mV/DIV at 100 kHz.
Vertical deflection not to exceed 2.2 divisions (20 mV/DIV) at 100 kHz.
Vertical deflection not to exceed 1.1 divisions (20 mV/DIV) at 1 kHz.
25. Check Isolation between + and $-$ Inputs (Page 5-32)
Max trace deflection 0.5 division when switching opposite channel to DC.
26. Check Amplifier Frequency Response (Page 5-33)
 -3 dB Frequency between 1 MHz and 1.3 MHz.
27. Current Probe Input Frequency Response (Page 5-34)
28. Check or Adjust Signal Out DC Level (R467) (Page 5-35)
Signal out zero volt when trace positioned vertically to graticule center.
29. Check Signal Out Dynamic Range (Page 5-37)
At least +5 volts and -5 volts display on Test Oscilloscope.
30. Check Signal Output Amplitude (Page 5-38)
5 volts, ± 1 volt.
31. Check or Adjust Signal Out Divider Compensation (C461) (Page 5-38)
Optimum leading corner of square wave (flat with minimum rounding or overshoot).

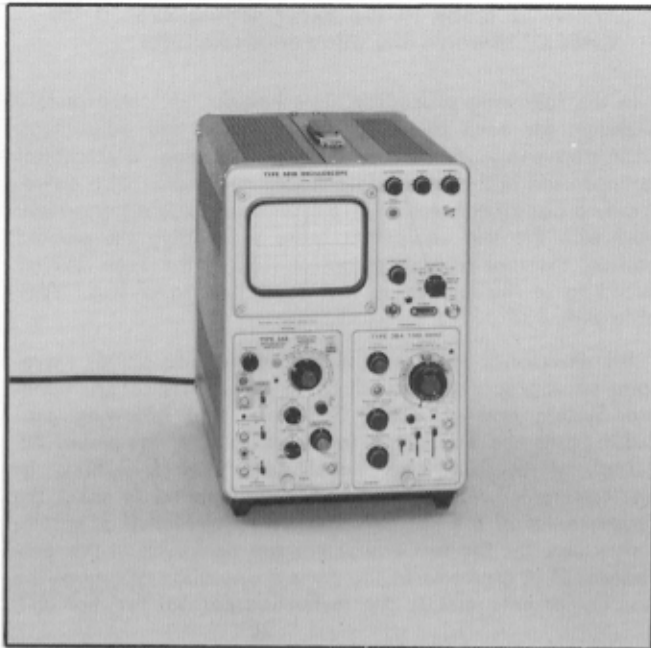

Fig. 5-1. Equipment required for steps 1 through 3.

VOLTS/DIV	10 mV
VARIABLE	CAL
POSITION	Midrange
UPPER -3 dB FREQUENCY	.1 kHz
LOWER -3 dB FREQUENCY	10 kHz
AC-GND-DC + INPUT	GND
AC-GND-DC - INPUT	GND
STEP ATTEN DC BAL	Midrange
DC OFFSET COURSE	Midrange (5 turns from either extreme)
DC OFFSET FINE	Midrange
CURRENT-VOLTS	VOLTS

5. Preset the Horizontal Time Base as follows:

Time/Div	.5 ms
Variable	Calib
Slope	+
Coupling	AC
Source	Int
Trigger Mode	Free Run

6. Turn on the oscilloscope power switch. Allow at least 20 minutes warm up for checking the instrument to the given accuracy.

1. Check or Adjust AC Atten Bal ❶

- a. Test equipment is shown in Fig. 5-1.
- b. Center the trace on the CRT with the POSITION control.
- c. Rotate the VOLTS/DIV switch from the 10 mV position to the 20 μ V position.

- d. CHECK—The trace should remain within 1.5 divisions of graticule center.
- e. ADJUST—AC Atten Bal control, R405, (see Fig. 5-2) to position the trace within 1.5 divisions of graticule center.

2. Check or Adjust Variable Bal ❷

- a. Test equipment is shown in Fig. 5-1.
- b. Set the Type 3A9 VOLTS/DIV switch to 10 mV.
- c. Position the trace to graticule center with the POSITION control.
- d. Rotate the VARIABLE (VOLTS/DIV) control counter-clockwise.
- e. CHECK—For trace shift not to exceed ± 0.2 divisions while rotating the VARIABLE control throughout its range.
- f. ADJUST—Variable Bal control, R425, (See Fig. 5-2) for no trace shift while rotating the VARIABLE control throughout its range.

3. Check or Adjust Coarse DC Bal ❸

- a. Test equipment is shown in Fig. 5-1.
- b. Set the VARIABLE (VOLTS/DIV) control to the CAL position.
- c. Set the LOWER -3 dB FREQUENCY selector to the DC position.
- d. CHECK—The trace should be within 0.1 division of graticule center.
- e. ADJUST—Coarse DC Bal, R345 (See Fig. 5-2) to position the trace to graticule center.

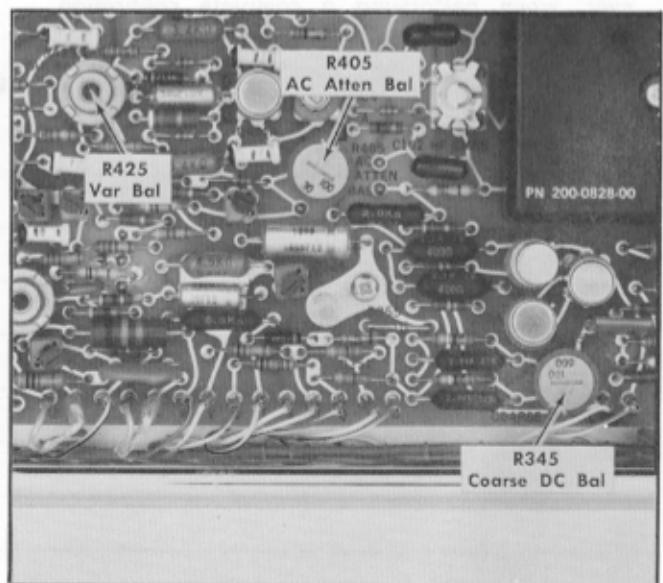

Fig. 5-2. Location of controls used in steps 1 through 3.

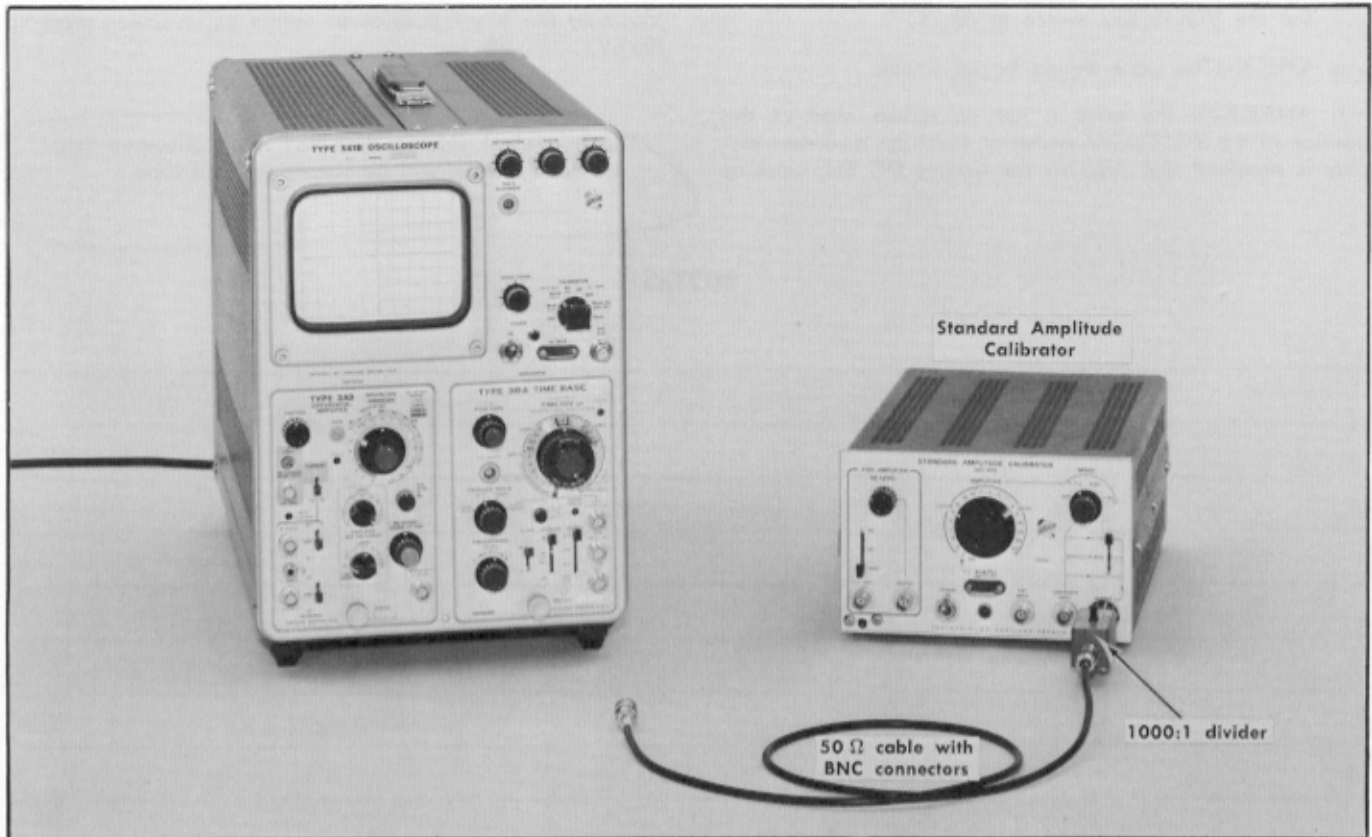

Fig. 5-3. Equipment required for steps 4 through 6.

Set the Type 3A9 controls:

VOLTS/DIV	1 mV
VARIABLE	CAL
POSITION	Midrange
UPPER —3 dB	
FREQUENCY	1 MHz
LOWER —3 dB FREQUENCY	DC
AC-GND-DC + INPUT	DC
AC-GND-DC — INPUT	GND
STEP ATTEN DC BAL	Adjust for DC balance as shown in Operating Section
CURRENT-VOLTS	VOLTS

Set the Time Base controls:

Time/Div	.5 ms
Variable	Calib
Slope	+
Coupling	AC
Source	Int
Trigger Mode	Auto

4. Check or Adjust Gain

- a. Test equipment is shown in Fig. 5-3.

- b. Connect a 5 mV peak-to-peak square wave from the Standard Amplitude Calibrator through the 1000:1 divider and a coaxial cable to the + INPUT connector.

- c. Set the 1000:1 divider to $\times 1$.

- d. Position the display as necessary, using the POSITION control.

- e. CHECK—The display for a vertical amplitude of exactly 5 div.

- f. ADJUST—The GAIN control, R435, front-panel adjustment, for exactly 5 divisions of display amplitude (See Fig. 5-4).

5. Check Variable Control Ratio

- a. Rotate the VARIABLE control fully counterclockwise.

- b. CHECK—The display amplitude should be 2 divisions or less to meet the 2.5:1 requirement.

- c. Reset the VARIABLE control to the CAL position.

6. Check Volts/Div Gain Switch

- a. Set the UPPER —3 dB FREQUENCY switch to 3 kHz.

- b. Set the LOWER —3 dB FREQUENCY switch to 1 Hz.

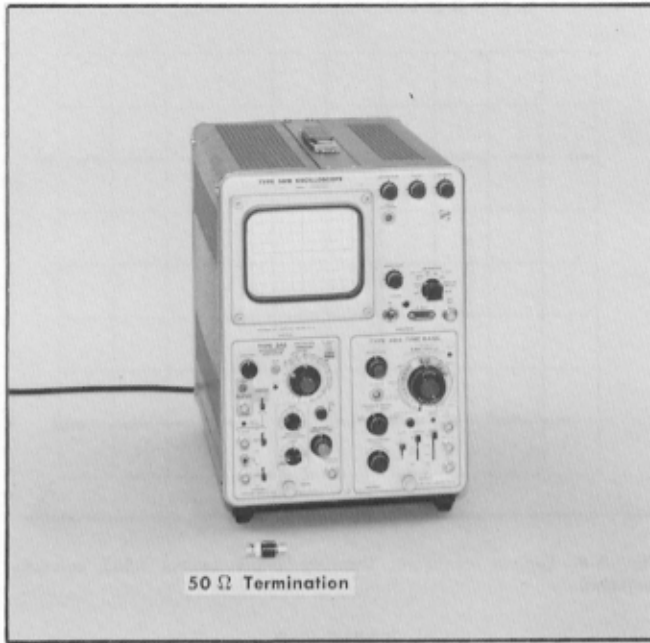

Fig. 5-5. Equipment required for steps 7 and 8.

Set the Type 3A9 controls:

VOLTS/DIV	10 μV
VARIABLE POSITION	CAL Midrange
UPPER -3 dB FREQUENCY	100 Hz
LOWER -3 dB FREQUENCY	DC
AC-GND-DC + INPUT	GND
AC-GND-DC - INPUT	GND
STEP ATTEN DC BAL	Adjust for DC balance
DC OFFSET COARSE	Midrange (5 turns from either extreme)
DC OFFSET FINE	Midrange
CURRENT-VOLTS	VOLTS

Set the Time Base controls:

Time/Div	.5 ms
Variable	Calib
Slope	+
Coupling	AC
Source	Int
Trigger Mode	Auto

7. Check or Adjust + Input Zero

- Test equipment is shown in Fig. 5-5.
- Connect a 50 Ω termination to the + INPUT connector.

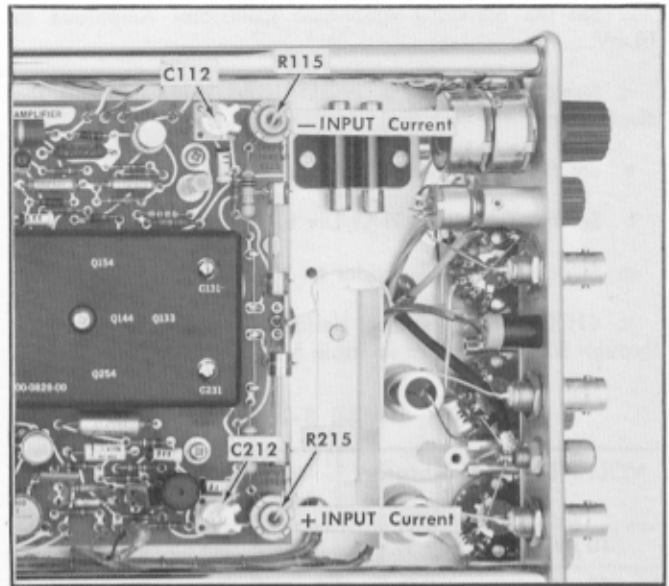

Fig. 5-6. Location of controls used in steps 7 and 8.

- Using the STEP ATTEN DC BAL control, position the trace to coincide with the graticule center.
- Set the + INPUT AC-GND-DC switch to AC.
- CHECK—For maximum trace shift within ± 1 div.
- ADJUST—The +INPUT Zero control, R215 (See Fig. 5-6) to return the trace to graticule center.
- RECHECK—(Only if an adjustment has been made). Return the AC-GND-DC switch to GND and back to AC. There should be no trace shift.
- Set the + Input AC-GND-DC switch to GND.

8. Check or Adjust - Input Zero

- Remove the 50 Ω termination from the +INPUT and connect it to the -INPUT connector.
- Position the trace to graticule center with the STEP ATTEN DC BAL control.
- Set the - Input AC-GND-DC switch to AC.
- CHECK—For maximum trace shift within ± 1 div.
- ADJUST—The - Input Zero control, R115, (see Fig. 5-6) to position the trace to graticule center.
- RECHECK—(Only if an adjustment has been made). Return the -Input AC-GND-DC switch to GND and back to AC. There should be no trace shift.
- Disconnect the 50 Ω termination.
- Set the -Input AC-GND-DC switch to GND.

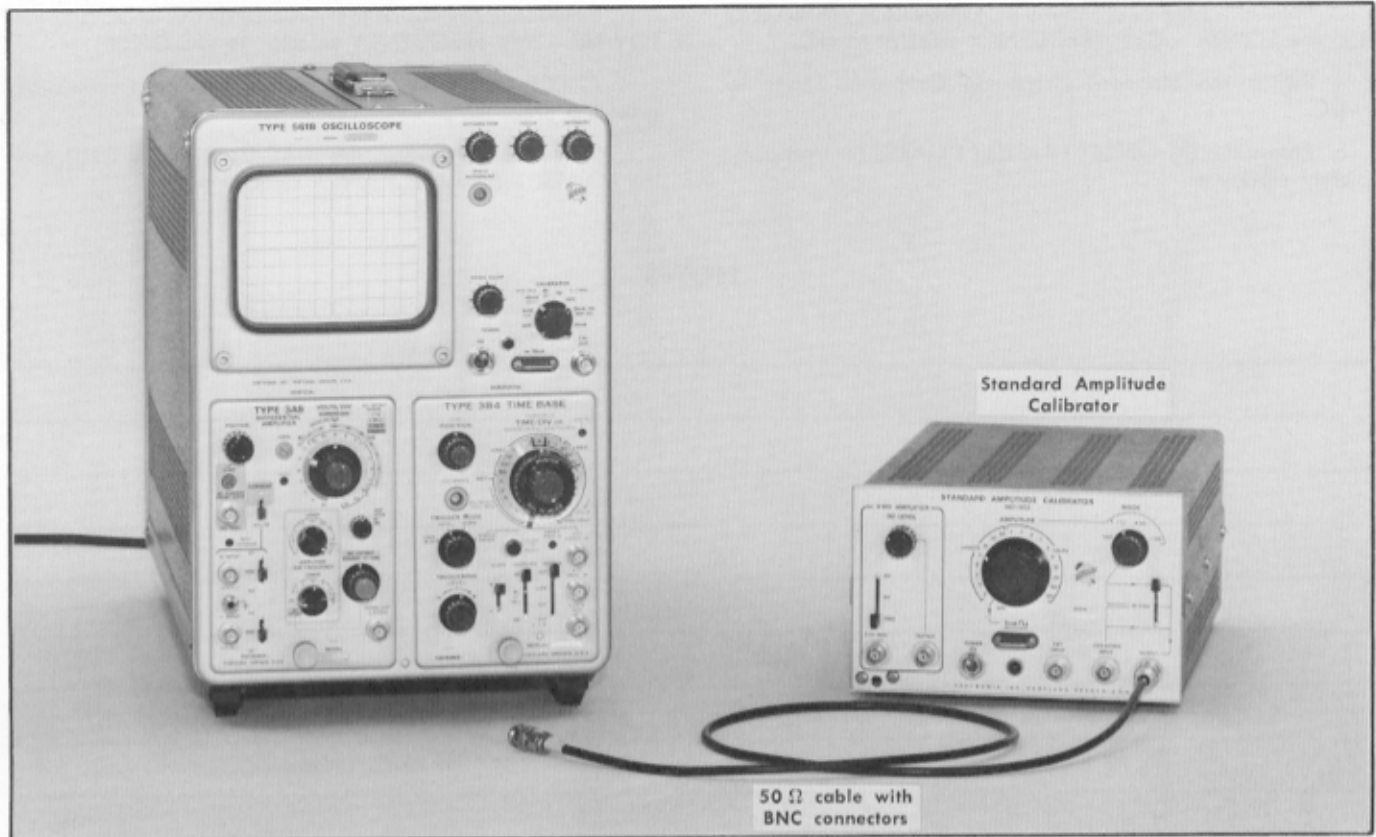

Fig. 5-7. Equipment required for step 9.

Set the Type 3A9 controls:

VOLTS/DIV	10 mV
VARIABLE POSITION	Counterclockwise
UPPER —3 dB FREQUENCY	1 MHz
LOWER —3 dB FREQUENCY	DC
AC-GND-DC +INPUT	GND
AC-GND-DC —INPUT	GND
STEP ATTEN DC BAL	Adjust for DC balance
CURRENT-VOLTS	VOLTS

Set the Time Base controls:

Time/Div	.2 μs
Variable	Calib
Slope	+
Coupling	AC
Source	Int
Trigger Mode	Free Run

9. Check DC Offset Range

a. Test equipment is shown in Fig. 5-7.

b. Set the Standard Amplitude Calibrator Amplitude to 50 mV and Mode to +DC.

c. Connect a coaxial cable between the Standard Amplitude Calibrator Output and the Type 3A9 +INPUT.

d. Set the trace to the graticule center line using the POSITION control.

e. Switch the +AC-GND-DC switch to DC.

f. Using the VOLTS/DIV VARIABLE position the trace to the second major graticule line above the center line.

g. Switch the +AC-GND-DC switch between DC and GND and check for exactly 2 divisions of deflection (leave the VARIABLE in the position just set. This calibrates the VARIABLE for 25 mV/DIV).

h. Switch the +AC-GND-DC switch to GND.

i. Rotate the DC OFFSET FINE and COARSE controls completely counterclockwise.

j. Set the Standard Amplitude Calibrator Amplitude to 1 volt.

k. Simultaneously switch the +AC-GND-DC switch to DC and the LOWER —3 dB FREQUENCY selector to DC OFFSET.

l. CHECK—The trace should return within the calibrated graticule area (+4 divisions at 25 mV/DIV = 100 mV).

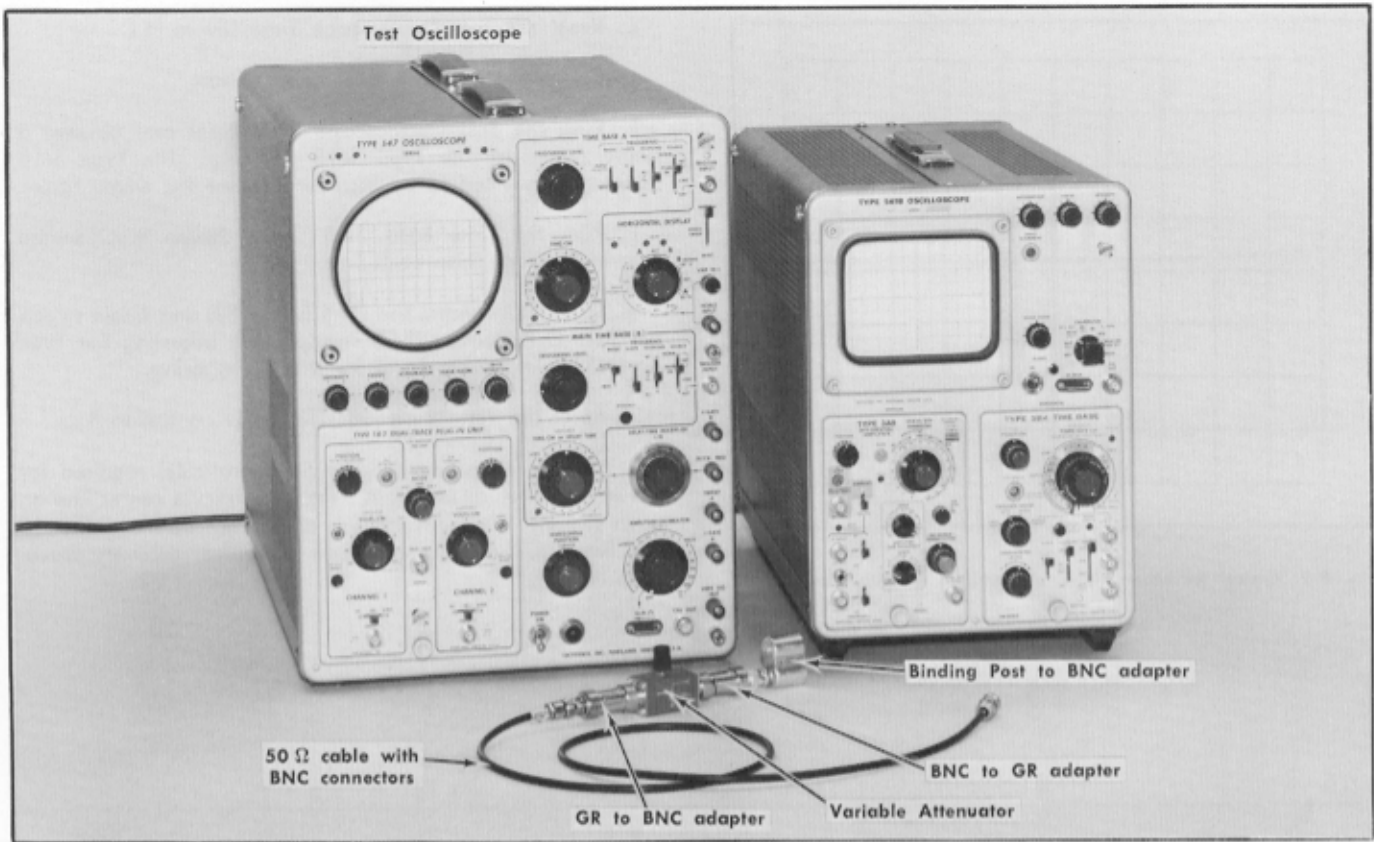

Fig. 5-8. Equipment required for step 10.

Set the Type 3A9 controls:

VOLTS/DIV	.5 V
VARIABLE	CAL
POSITION	Midrange
UPPER -3 dB FREQUENCY	1 MHz
LOWER -3 dB FREQUENCY	DC
AC-GND-DC +INPUT	GND
STEP ATTEN DC BAL	Adjusted for DC balance
CURRENT-VOLTS	VOLTS

Set the Time Base controls:

Time/Div	1 ms
Variable	Calib
Slope	—
Coupling	AC
Source	Int
Trigger Mode	Auto

Set the Test Oscilloscope controls:

Time/Div	50 μ s
Variable	Calib
Slope	+
Coupling	AC
Source	Int
Trigger Mode	Auto

10. Check Overdrive Recovery Time

- Test equipment is shown in Fig. 5-8.
- Connect, from the Test Oscilloscope (Type 547) + Gate Out, a binding post to BNC adapter, a BNC male to GR adapter, a variable attenuator, a GR to BNC female adapter and a cable with BNC connectors, to the Type 3A9 +INPUT.
- Adjust the variable attenuator to give a display amplitude, on the Type 561B graticule, of 1 volt (2 divisions).
- Leave the variable attenuator at this setting and reset the Type 3A9 VOLTS/DIV to 1 mV.
- Reset the Test Oscilloscope Trigger Mode to Single Sweep.
- Reset the Time Base controls as follows:

Time/Div	50 μ s
Trigger Mode	Free Run
Triggering Level	Slightly negative
- Set the Type 3A9 POSITION control to place the trace at the graticule center horizontal line.
- Reset the Time Base (3B4) Trigger Mode to Single Sweep.

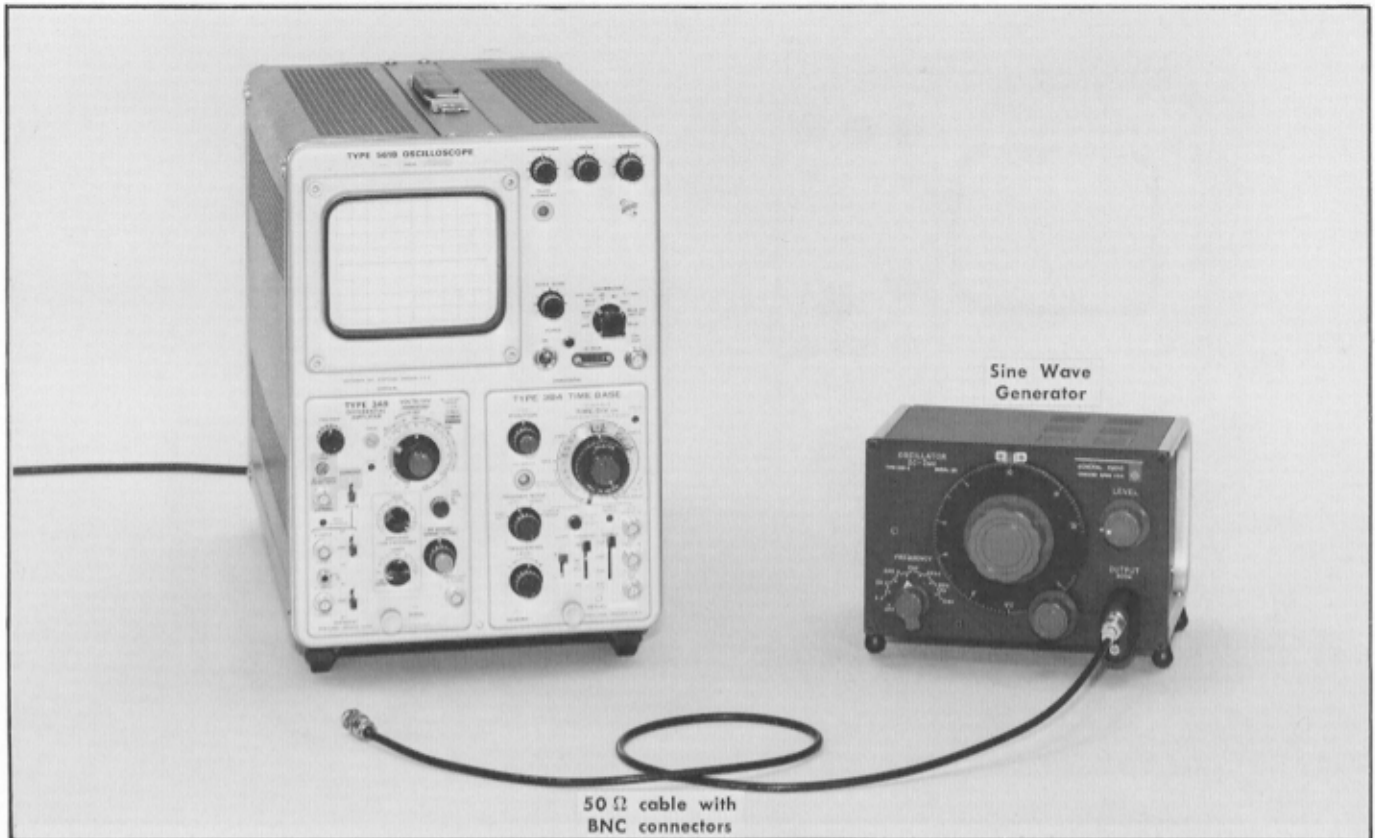

Fig. 5-10. Equipment required for step 11.

Set the Type 3A9 controls:

VOLTS/DIV	10 mV
VARIABLE	CAL
POSITION	Midrange
UPPER -3 dB FREQUENCY	1 MHz
LOWER -3 dB FREQUENCY	DC
AC-GND-DC +INPUT	DC
AC-GND-DC -INPUT	GND
STEP ATTEN DC BAL	Adjusted for DC balance
CURRENT-VOLTS	VOLTS

Set the Time Base controls:

Time/Div	1 ms
Variable	Calib
Slope	+
Coupling	AC
Source	Int
Trigger Mode	Auto

11. Check Input Overdrive Indicator

- Test equipment is shown in Fig. 5-10.
- Connect the Sine Wave Generator Output to the Type 3A9 +INPUT. Set the sine wave level at minimum amplitude.
- Set the Sine Wave Generator Frequency to 1 kHz.
- Switch +AC-GND-DC switch to DC.
- Increase the amplitude level of the sine wave until the Type 3A9 INPUT OVERDRIVE lamp lights.
- Reset the Type 3A9 VOLTS/DIV switch to .5 volt.
- CHECK—The sine wave amplitude, peak to peak, and divide by 2 to find the + or - driving signal amplitude. The overdriving signal should lie between 0.75 and 1.0 volt.
- Disconnect the Sine Wave Generator.

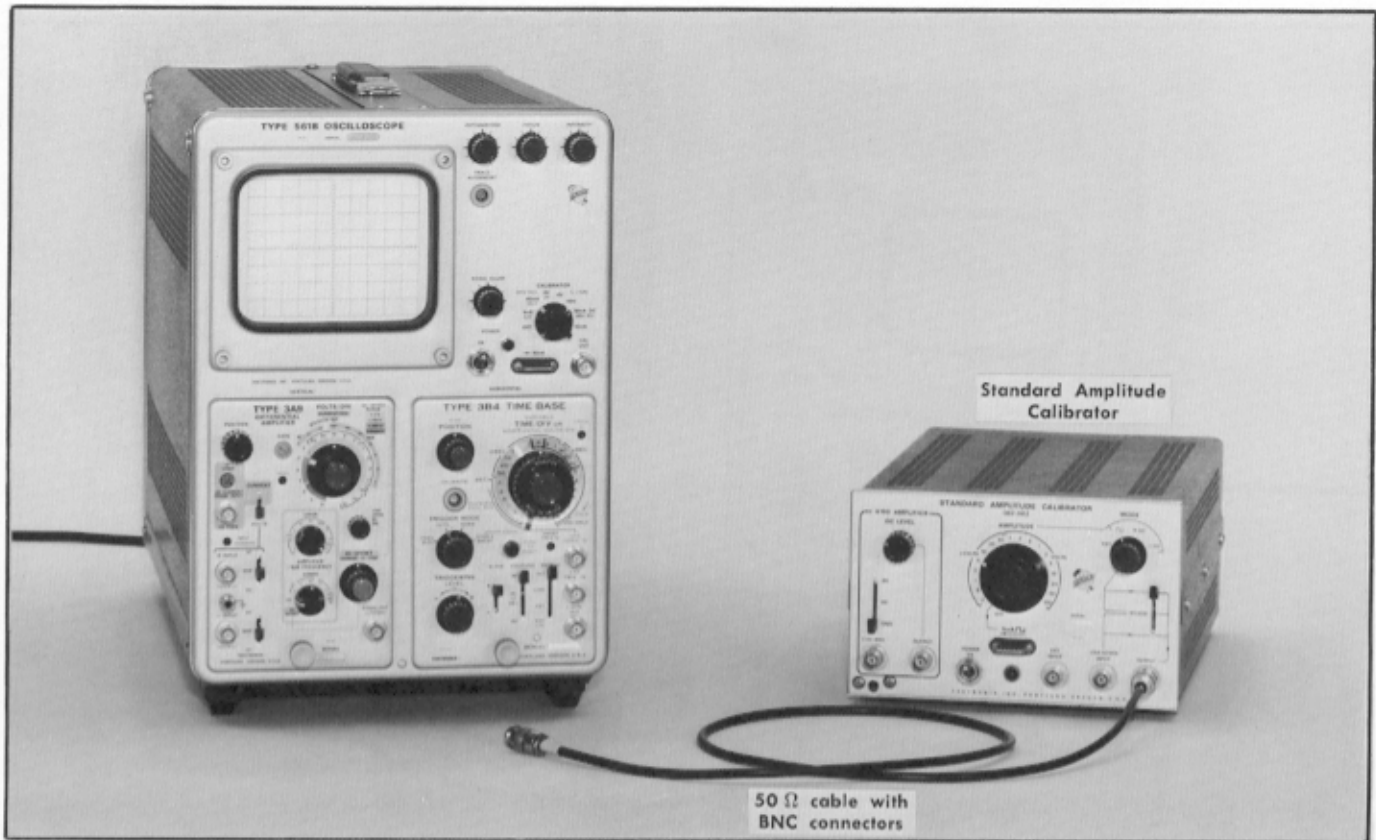

Fig. 5-11. Equipment required for steps 12 and 13.

Set the Type 3A9 controls:

VOLTS/DIV	10 mV
VARIABLE	CAL
POSITION	Midrange
UPPER —3 dB FREQUENCY	1 MHz
LOWER —3 dB FREQUENCY	DC
AC-GND-DC +INPUT	DC
AC-GND-DC —INPUT	GND
STEP ATTEN DC BAL	Adjusted for DC Balance
DC OFFSET COARSE	Midrange
DC OFFSET FINE	Midrange
CURRENT-VOLTS	VOLTS

Set the Time Base controls:

Time/Div	.5 ms
Variable	Calib
Slope	+
Coupling	AC
Source	Int
Trigger Mode	Auto

12. Check or Adjust Cross Neutralization (C131) ❶

- a. Test equipment is shown in Fig. 5-11.
- b. Set the Standard Amplitude Calibrator Amplitude to .5 V square wave.
- c. Connect a coaxial cable between the Standard Amplitude Calibrator Output and the Type 3A9 +INPUT.
- d. Set the Type 3A9 LOWER —3 dB FREQUENCY selector to DC OFFSET.
- e. Adjust DC OFFSET COARSE and FINE controls to position the top of the square wave to the graticule center.

NOTE

- From this point in the procedure, the Type 3A9 POSITION control and the Time Base Position control may not always be mentioned. Use these controls whenever it is necessary to position the display for best viewing.
- f. Switch the —AC-GND-DC switch to DC.
 - g. CHECK—The upper leading corner of the waveform, and note any aberration that occurs with the —AC-GND-DC switch in the DC position. The waveform should appear similar to the one in Fig. 5-12.

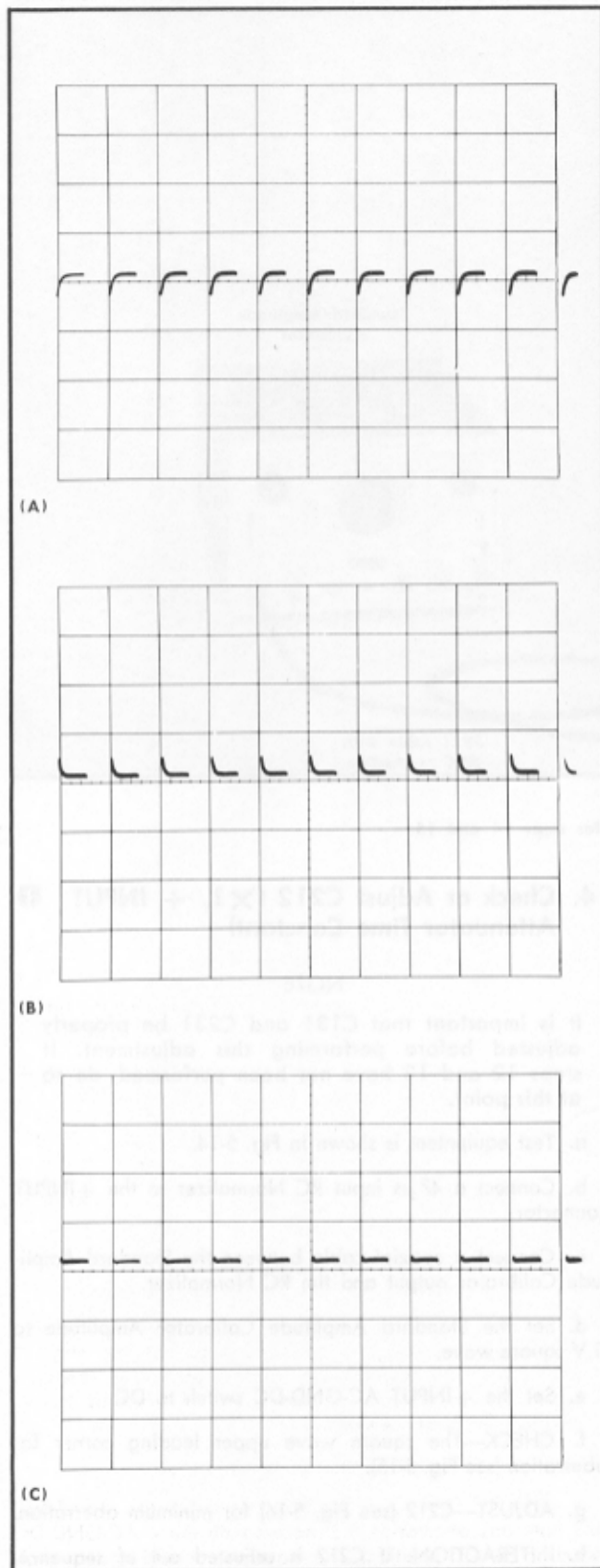

Fig. 5-12. Typical waveforms showing (A) and (B) C131 misadjusted and (C) C131 correctly adjusted.

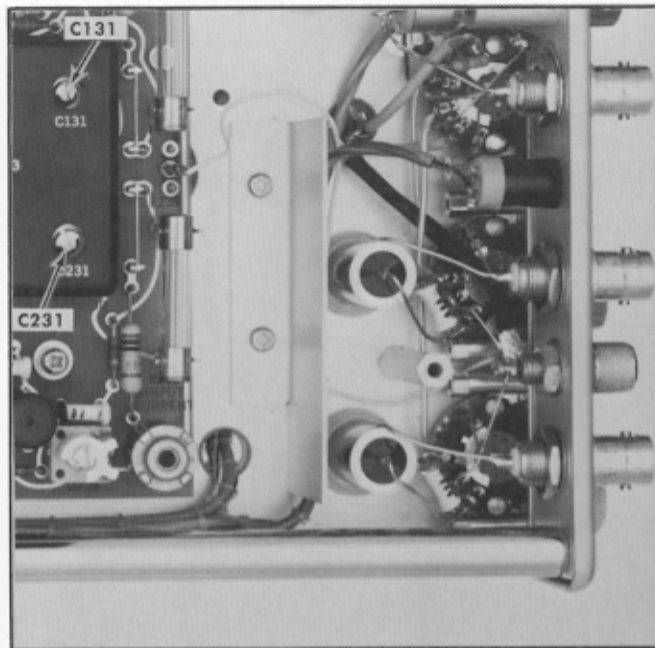

Fig. 5-13. Location of C131 and C231.

h. ADJUST—C131 (see Fig. 5-13) for minimum aberration on the upper leading corner of the waveform.

i. INTERACTION—C131 affects the $\times 1$ input capacitance and all other input attenuator adjustments. If C131 is adjusted out of sequence, steps 14, 15, 16, 19 and 21 must also be performed.

13. Check or Adjust Cross Neutralization (C231) ①

a. Disconnect the signal from the +INPUT connector and connect to the -INPUT connector.

b. Set the +INPUT-GND-DC switch to GND.

c. Set the -INPUT AC-GND-DC switch to DC.

d. Adjust DC OFFSET COARSE and FINE controls to bring the bottom of the waveform to the graticule center line.

e. Check the lower leading corner of the second cycle of the display and note any aberration that occurs with the +INPUT AC-GND-DC switch in the DC position.

f. ADJUST—C231 (see Fig. 5-13) for minimum aberration on the bottom leading corner of the waveform.

g. INTERACTION: C231 affects the $\times 1$ input capacitance and all other input attenuator adjustments. If C231 is adjusted out of sequence, steps 14, 15, 16, 19 and 21 must be performed.

h. Disconnect the Standard Amplitude Calibrator signal.

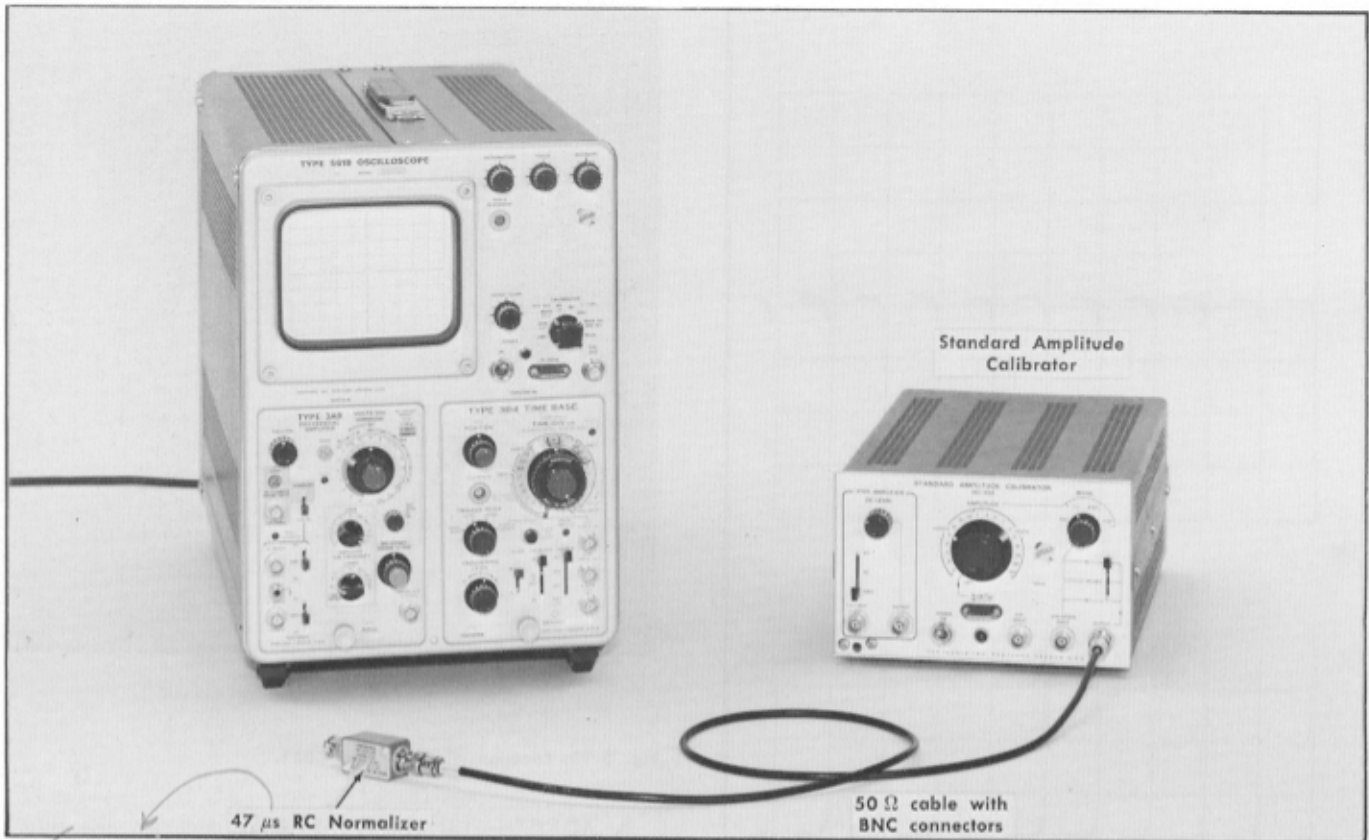

Fig. 5-14. Equipment required for steps 14 and 15.

Set the Type 3A9 controls:

VOLTS/DIV	10 mV
VARIABLE	CAL
POSITION	Midrange
UPPER -3 dB FREQUENCY	1 MHz
LOWER -3 dB FREQUENCY	DC
AC-GND-DC +INPUT	GND
AC-GND-DC -INPUT	GND
STEP ATTEN DC BAL	Adjusted for DC balance
DC OFFSET COARSE	Midrange
DC OFFSET FINE	Midrange
CURRENT-VOLTS	VOLTS

Set the Time Base controls:

Time/Div	.5 ms
Variable	Calib
Slope	+
Coupling	AC
Source	Int
Trigger Mode	Auto

14. Check or Adjust C212 ($\times 1$, + INPUT $\text{\textcircled{1}}$ Attenuator Time Constant)

NOTE

It is important that C131 and C231 be properly adjusted before performing this adjustment. If steps 12 and 13 have not been performed, do so at this point.

- Test equipment is shown in Fig. 5-14.
- Connect a $47 \mu\text{s}$ input RC Normalizer to the +INPUT connector.
- Connect a coaxial cable between the Standard Amplitude Calibrator output and the RC Normalizer.
- Set the Standard Amplitude Calibrator Amplitude to .1 V square wave.
- Set the +INPUT AC-GND-DC switch to DC.
- CHECK—The square wave upper leading corner for aberration (see Fig. 5-15).
- ADJUST—C212 (see Fig. 5-16) for minimum aberration.
- INTERACTION: If C212 is adjusted out of sequence, steps 14 and 16 through 19 must also be performed.

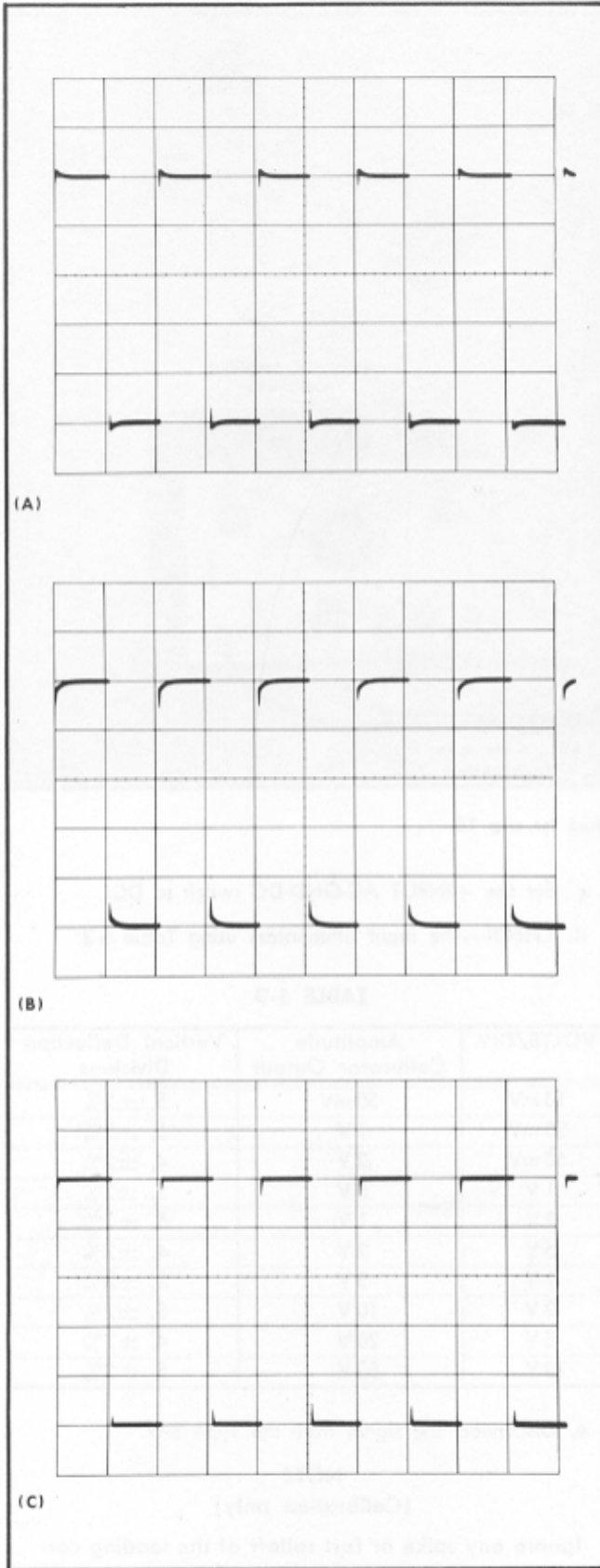

Fig. 5-15. Typical waveforms showing (A) and (B) C212 misadjusted and (C) C212 correctly adjusted.

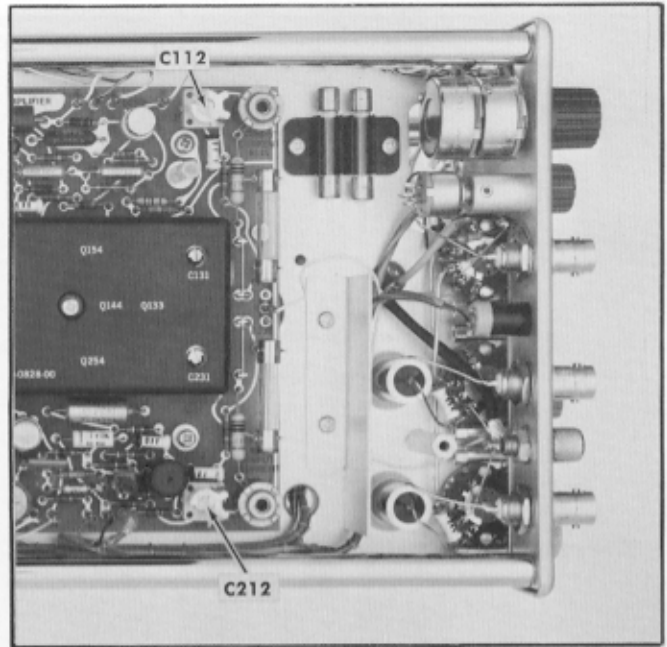

Fig. 5-16. Location of C212 and C112.

15. Check or Adjust C112 ($\times 1$, — INPUT $\text{\textcircled{1}}$ Attenuator Time Constant)

- a. Disconnect the RC Normalizer from the +INPUT and connect it to the —INPUT.
- b. Set the Type 3A9 controls as follows:

AC-GND-DC +INPUT	GND
AC-GND-DC —INPUT	DC
- c. CHECK—The square wave bottom leading corner for aberration.
- d. ADJUST—C112 (see Fig. 5-16) for minimum aberration.
- e. INTERACTION: If C112 is adjusted out of sequence, steps 13 and 16 through 19 must also be performed.
- f. Disconnect the signal and the Normalizer.

NOTES

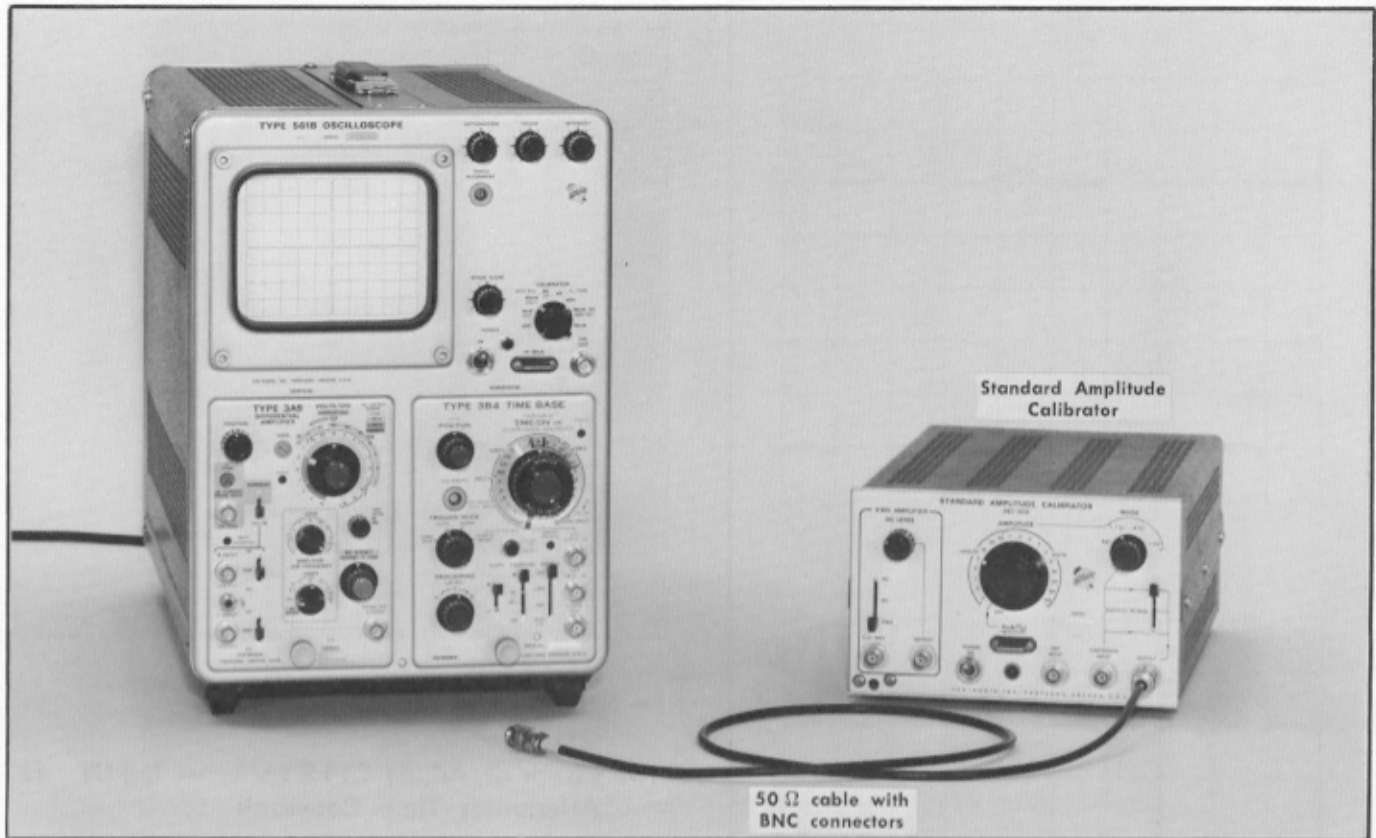

Fig. 5-17. Equipment required for step 16.

Set the Type 3A9 controls:

VOLTS/DIV	10 mV
VARIABLE	CAL
POSITION	Midrange
UPPER -3 dB FREQUENCY	1 MHz
LOWER -3 dB FREQUENCY	DC
AC-GND-DC +INPUT	GND
AC-GND-DC -INPUT	GND
STEP ATTEN DC BAL	Adjusted for DC balance
DC OFFSET COARSE	Midrange
DC OFFSET FINE	Midrange
CURRENT-VOLTS	VOLTS

Set the Time Base controls:

Time/Div	.5 ms
Variable	Calib
Slope	+
Coupling	AC
Source	Int
Trigger Mode	Auto

16. Check Input Attenuator Accuracy

- Test equipment is shown in Fig. 5-17.
- Connect a 50 mV peak-to-peak square wave from the Standard Amplitude Calibrator through a coaxial cable to the +INPUT.

- Set the +INPUT AC-GND-DC switch to DC.
- CHECK—The input attenuators using Table 5-3.

TABLE 5-3

VOLTS/DIV	Amplitude Calibrator Output	Vertical Deflection Divisions
10 mV	50 mV	5, $\pm 2\%$
20 mV	.1 V	5, $\pm 2\%$
50 mV	.2 V	4, $\pm 2\%$
.1 V	.5 V	5, $\pm 2\%$
.2 V	1 V	5, $\pm 2\%$
.5 V	2 V	4, $\pm 2\%$
1 V	5 V	5, $\pm 2\%$
2 V	10 V	5, $\pm 2\%$
5 V	20 V	4, $\pm 2\%$
10 V	50 V	5, $\pm 2\%$

- Disconnect the signal from the Type 3A9.

NOTE
(Calibration only)

Ignore any spike or fast rolloff of the leading corner of the square wave when checking from 20 mV/DIV to 10 V/DIV as they will be adjusted in step 17.

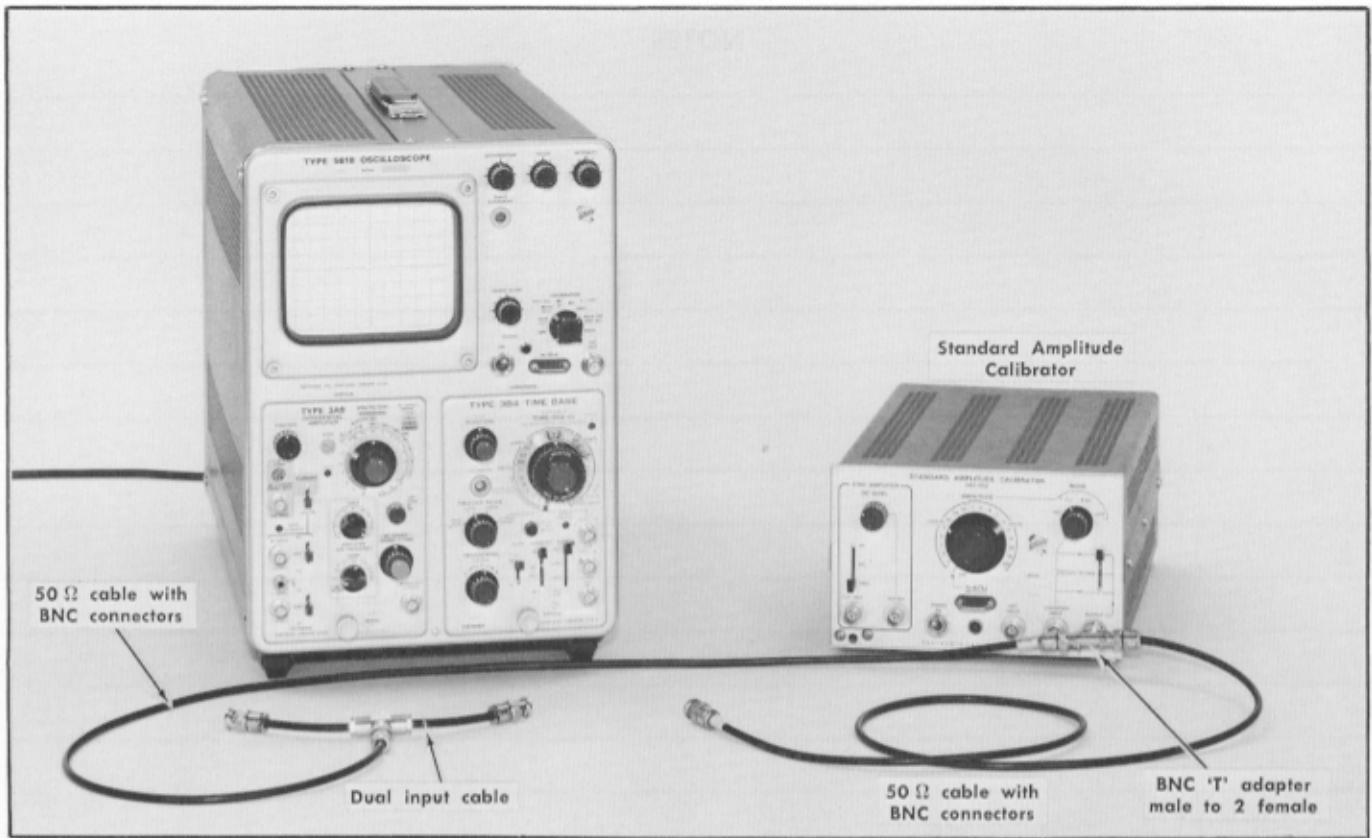

Fig. 5-18. Equipment required for step 17.

Set the Type 3A9 controls:

VOLTS/DIV	50 mV
VARIABLE	CAL
POSITION	Midrange
UPPER -3 dB FREQUENCY	1 MHz
LOWER -3 dB FREQUENCY	DC
AC-GND-DC +INPUT	DC
AC-GND-DC -INPUT	DC
STEP ATTEN DC BAL	Adjusted for DC balance
DC OFFSET COARSE	Midrange
DC OFFSET FINE	Midrange
CURRENT-VOLTS	VOLTS

Set the Time Base controls:

Time/Div	.5 ms
Variable	Calib
Slope	+
Coupling	AC
Source	Ext
Trigger Mode	Auto

17. Check or Adjust Input Attenuator Differential Balance ❶

- a. Test equipment is shown in Fig. 5-18.
- b. Connect a BNC T connector to the Standard Amplitude Calibrator Output connector.
- c. Connect a BNC dual input cable to the +INPUT and -INPUT connectors on the Type 3A9.
- d. Connect a coaxial cable between the T connector and the dual input cable. Connect a coaxial cable between the T connector and the Ext Trig In connector on the Time Base.
- e. Set the Standard Amplitude Calibrator Amplitude to 50 V.
- f. CHECK—For optimum differential (minimum display amplitude) balance as shown in Fig. 5-19, (disregard any spikes on the waveform) for each of the switch positions shown in Table 5-4.
- g. ADJUST—R205, R207 and R209 (see Fig. 5-20) for optimum differential balance as shown in Table 5-4.

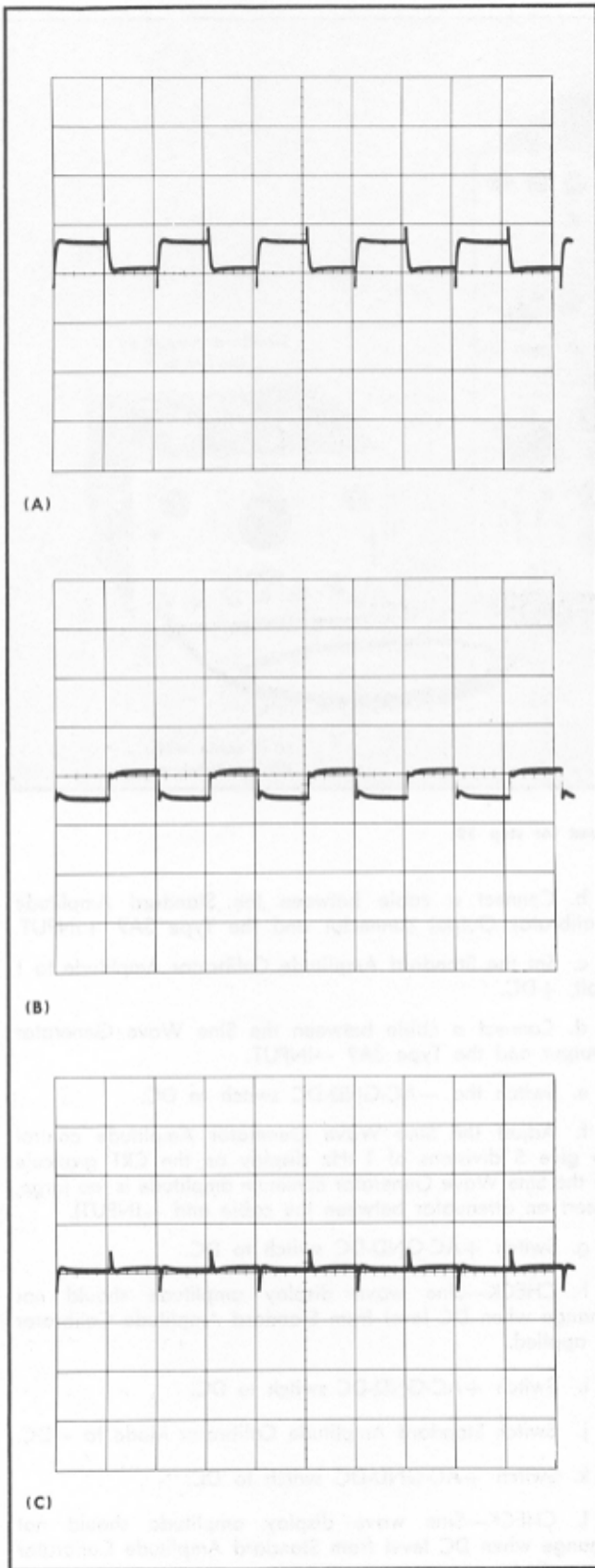

Fig. 5-19. Typical waveforms showing (A) and (B) R205E mis-adjusted and (C) R205E correctly adjusted.

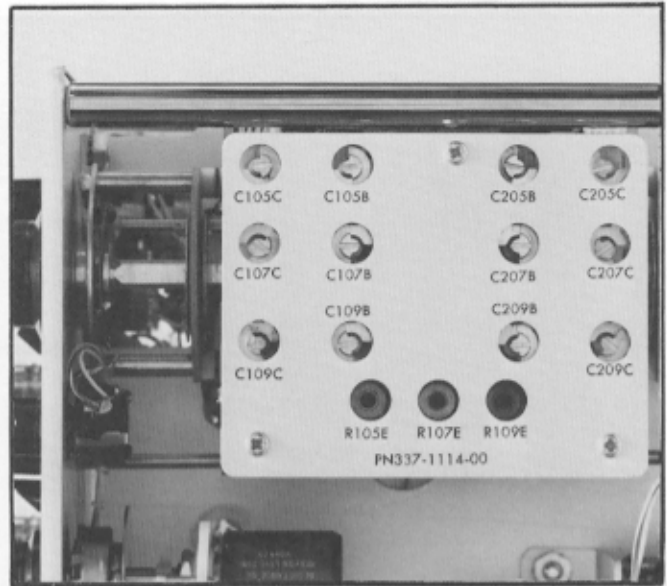

Fig. 5-20. Location of controls.

TABLE 5-4

VOLTS/DIV	Standard Amplitude Calibrator Output	Check or Adjust for null
50 mV	50 V	R205E
20 mV	50 V	Check
.1 V	50 V	Check
.5 V	100 V	R207E
.2 V	100 V	Check
1 V	100 V	Check
5 V	100 V	R209E
2 V	100 V	Check
10 V	100 V	Check

h. Set the Standard Amplitude Calibrator Amplitude to .2 V.

i. Disconnect all signal connections from the Type 3A9.

NOTES

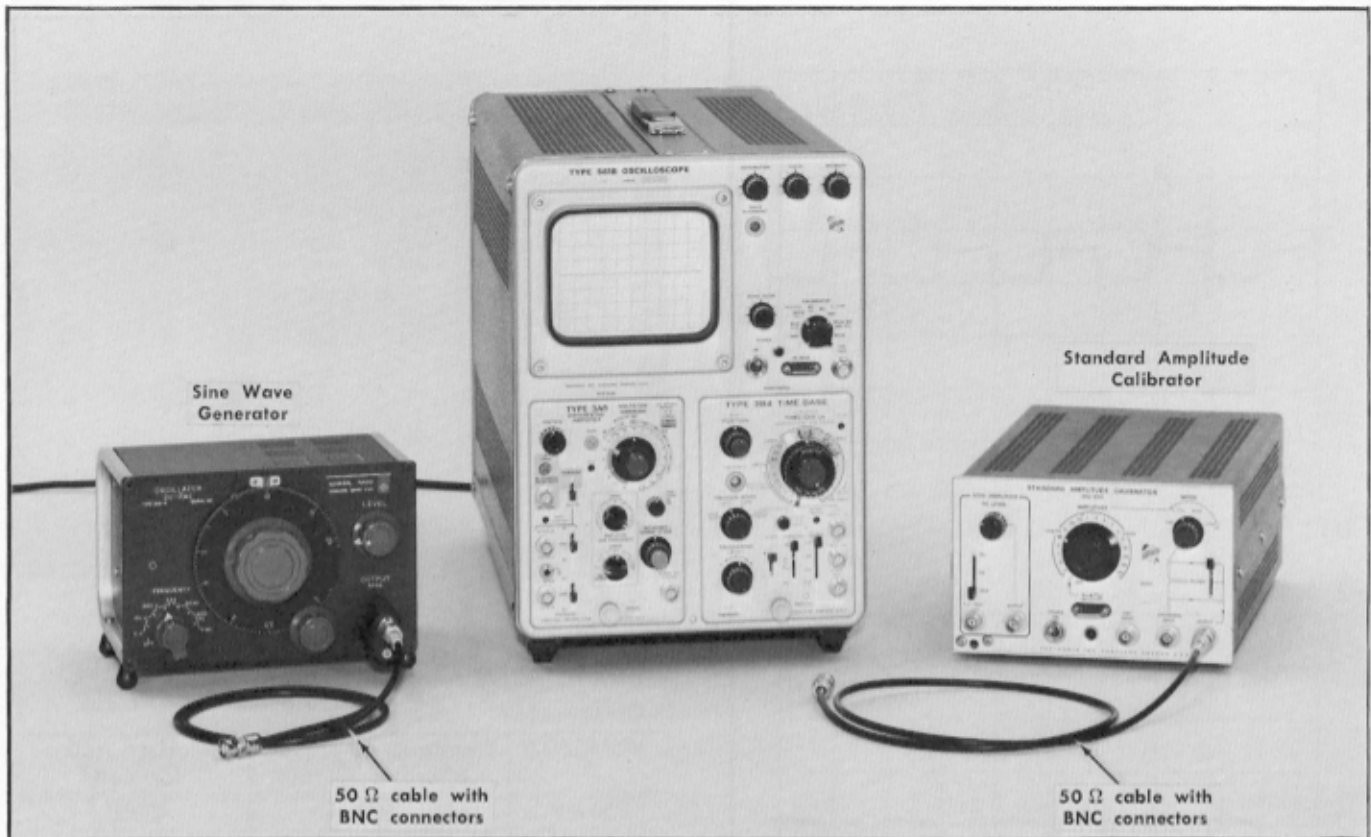

Fig. 5-21. Equipment required for step 18.

Set the Type 3A9 controls:

VOLTS/DIV	1 mV
VARIABLE	CAL
POSITION	Midrange
UPPER —3 dB FREQUENCY	1 MHz
LOWER —3 dB FREQUENCY	10 Hz
AC-GND-DC +INPUT	GND
AC-GND-DC —INPUT	GND
STEP ATTEN DC BAL	Adjusted for DC balance
CURRENT-VOLTS	VOLTS

Set the Time Base controls:

Time/Div	1 ms
Variable	Calib
Slope	+
Coupling	AC
Source	Int
Trigger Mode	Auto

18. Check Differential Dynamic Range

a. Test equipment is shown in Fig. 5-20.

b. Connect a cable between the Standard Amplitude Calibrator Output connector and the Type 3A9 +INPUT.

c. Set the Standard Amplitude Calibrator Amplitude to 1 volt, +DC.

d. Connect a cable between the Sine Wave Generator Output and the Type 3A9 —INPUT.

e. Switch the —AC-GND-DC switch to DC.

f. Adjust the Sine Wave Generator Amplitude control to give 5 divisions of 1 kHz display on the CRT graticule (if the Sine Wave Generator minimum amplitude is too large, insert an attenuator between the cable and —INPUT).

g. Switch +AC-GND-DC switch to DC.

h. CHECK—Sine wave display amplitude should not change when DC level from Standard Amplitude Calibrator is applied.

i. Switch +AC-GND-DC switch to DC.

j. Switch Standard Amplitude Calibrator Mode to —DC.

k. Switch +AC-GND-DC switch to DC.

l. CHECK—Sine wave display amplitude should not change when DC level from Standard Amplitude Calibrator is applied.

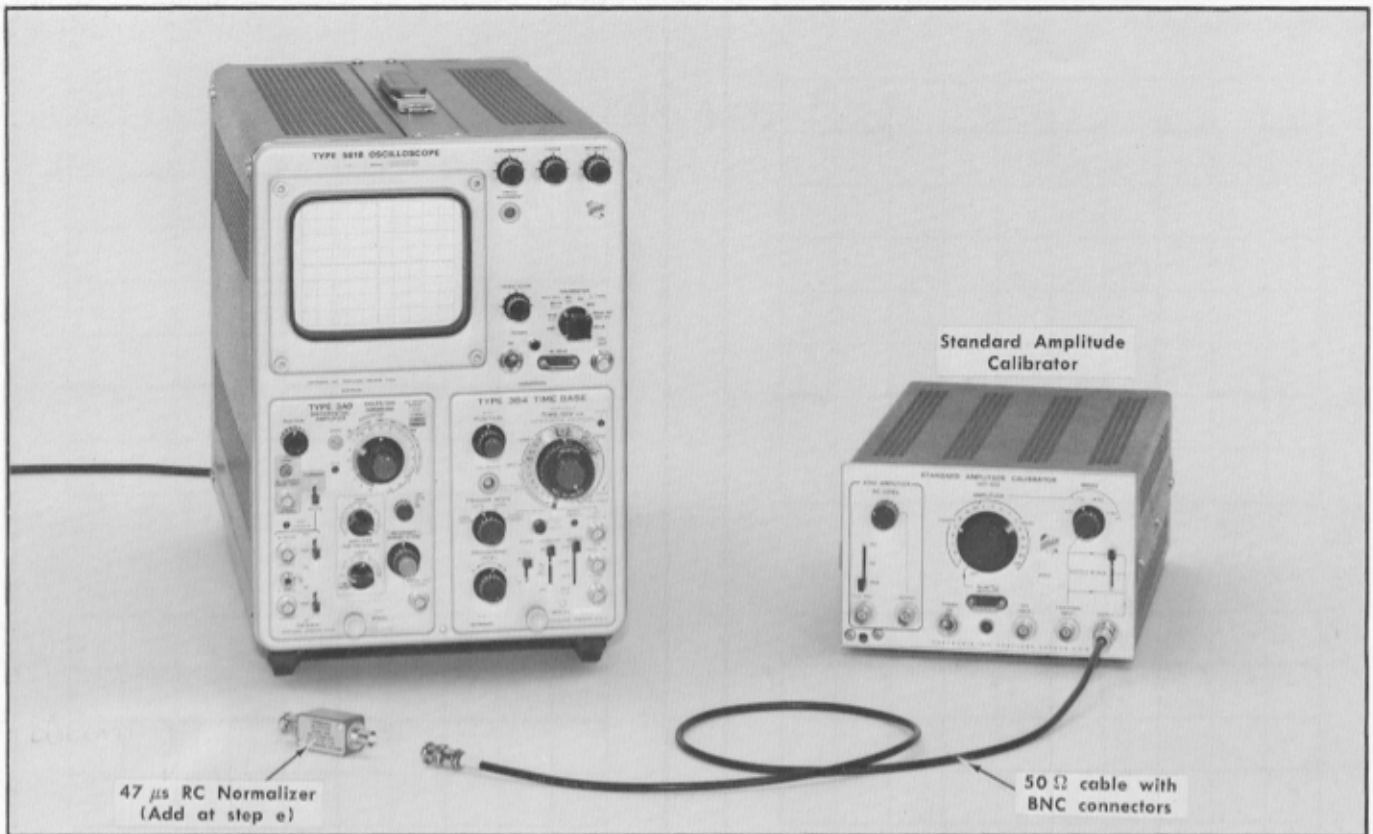

Fig. 5-22. Equipment required for step 19.

Set the Type 3A9 controls:

VOLTS/DIV	50 mV
VARIABLE	CAL
POSITION	Midrange
UPPER —3 dB FREQUENCY	1 MHz
LOWER —3 dB FREQUENCY	DC
AC-GND-DC +INPUT	DC
AC-GND-DC —INPUT	GND
STEP ATTEN DC BAL	Adjusted for DC balance
DC OFFSET COARSE	Midrange
DC OFFSET FINE	Midrange
CURRENT-VOLTS	VOLTS

Set the Time Base controls:

Time/Div	.5 ms
Variable	Calib
Slope	+
Coupling	AC
Source	Int
Trigger Mode	Auto

19. Check or Adjust + Input Attenuator Compensation ①

- a. Test equipment is shown in Fig. 5-22.
- b. Connect a .2V square wave from the Standard Amplitude Calibrator Output through a coaxial cable to the +INPUT connector of the Type 3A9.
- c. CHECK—the displayed square wave for rolloff, overshoot and level at the Calibrator and VOLTS/DIV switch positions shown in Table 5-5.
- d. ADJUST—to give optimum square wave response as shown in Fig. 5-23, at each of the Calibrator and VOLTS/DIV switch positions shown in Table 5-5.
- e. Insert the 47 μ s RC Normalizer between the signal cable and the +INPUT connector.
- f. CHECK—for optimum flat top on the square wave as shown in Fig. 5-24, at each of the Calibrator and VOLTS/DIV switch positions shown in Table 5-6.
- g. ADJUST—to give optimum flat top on the square wave as shown in Fig. 5-24, at each of the Calibrator and VOLTS/DIV switch positions shown in Table 5-6.

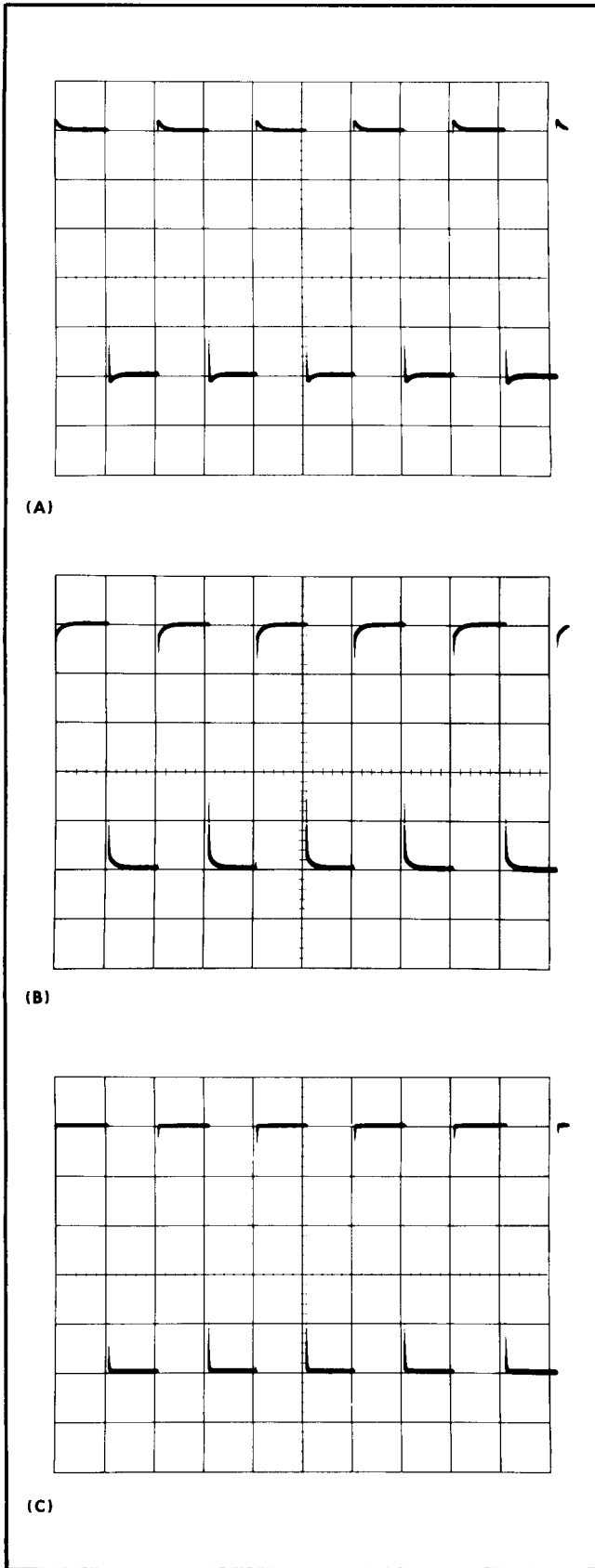

Fig. 5-23. Typical waveforms show (A) and (B) C105C misadjusted and (C) C105C correctly adjusted.

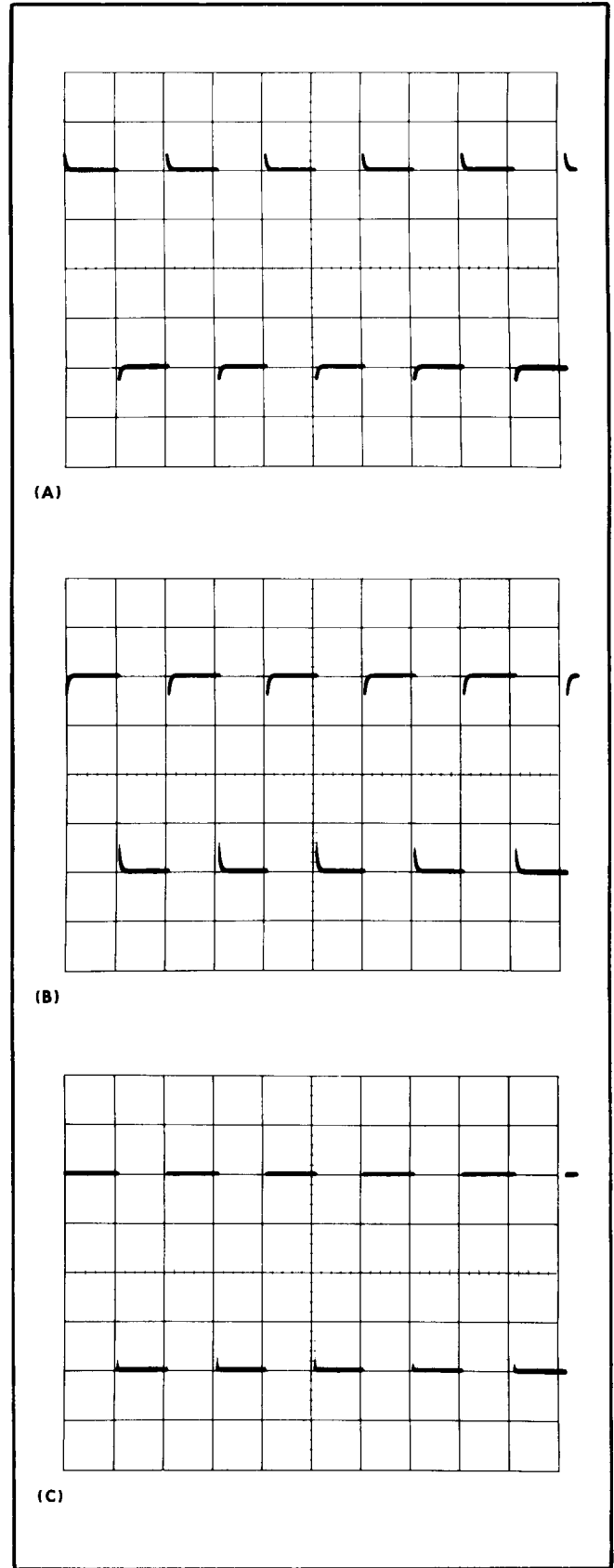

Fig. 5-24. Typical waveforms showing (A) and (B) C199B misadjusted and (C) C109B correctly adjusted.

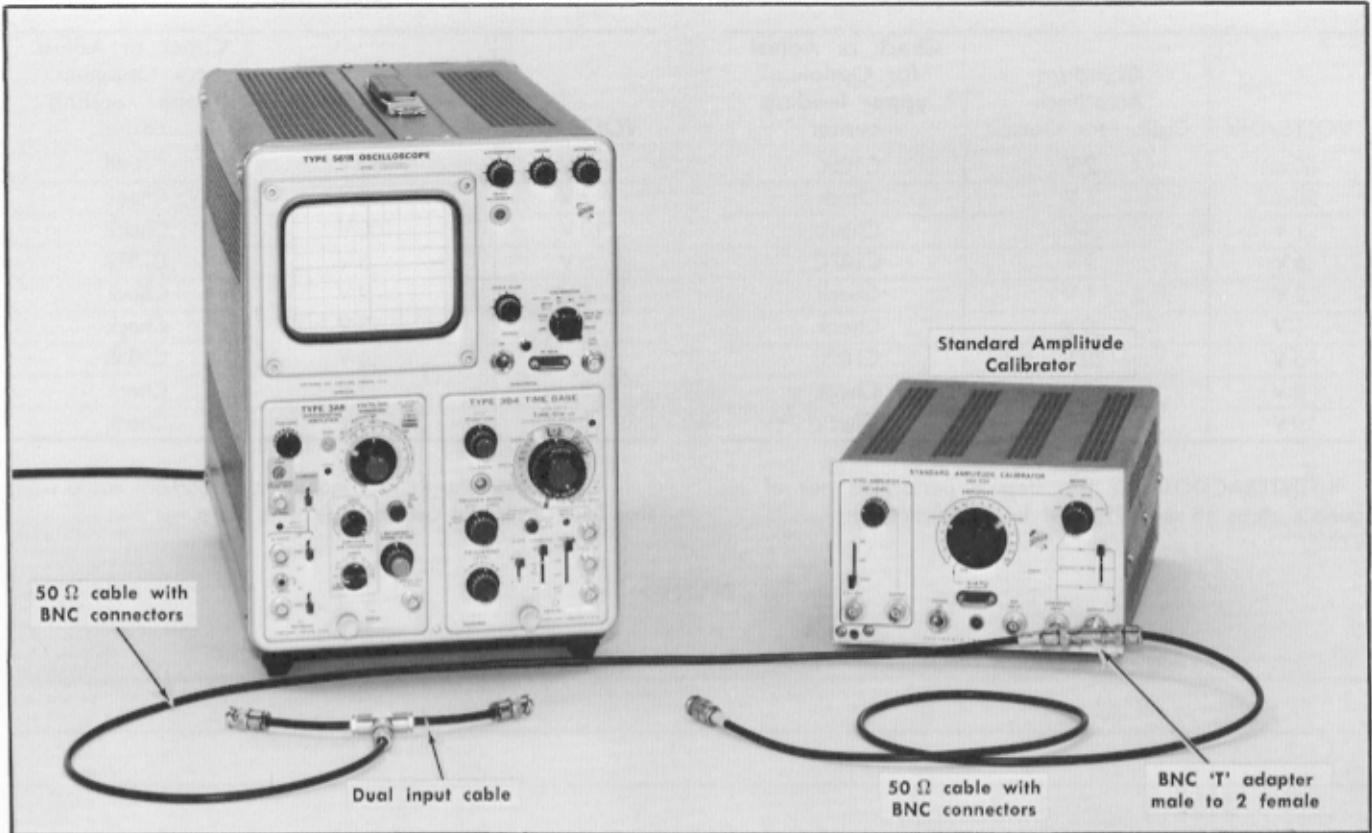

Fig. 5-25. Equipment required for step 20.

Set the Type 3A9 controls:

VOLTS/DIV	50 mV
VARIABLE	CAL
POSITION	Midrange
UPPER -3 dB FREQUENCY	1 MHz
LOWER -3 dB FREQUENCY	DC
AC-GND-DC + INPUT	DC
AC-GND-DC - INPUT	DC
STEP ATTEN DC BAL	Adjusted for DC balance
DC OFFSET COARSE	Midrange
DC OFFSET FINE	Midrange
CURRENT-VOLTS	VOLTS

Set Time Base Controls:

Time/Div	.5 ms
Variable	Calib
Slope	+
Coupling	AC
Source	Ext
Trigger Mode	Auto

20. Check or Adjust — Input Attenuator ❶

- a. Test equipment is shown in Fig. 5-25.
- b. Connect a BNC T connector to the Standard Amplitude Calibrator Output.

TABLE 5-7

Standard Amplitude Calibrator Output	VOLTS/DIV	Check or Adjust for spike amplitude
50 V	50 V	C205C
	20 V	Check
	.1 V	Check
100 V	.5 V	C207C
	.2 V	Check
	1 V	Check
	5 V	C209C
	2 V	Check
	10 V	Check

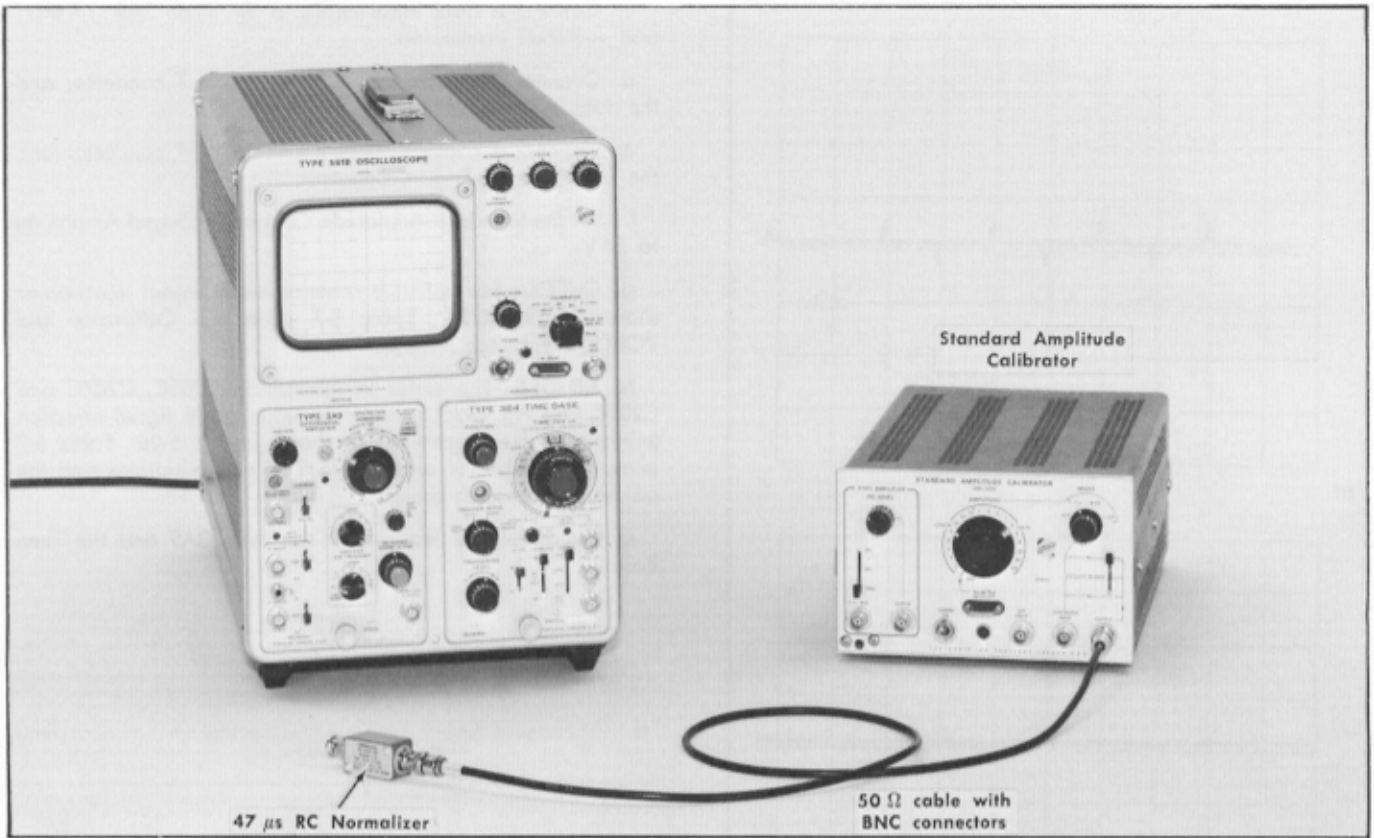

Fig. 5-27. Equipment required for step 21.

Set the Type 3A9 controls:

VOLTS/DIV	50 mV
VARIABLE POSITION	CAL Midrange
UPPER -3 dB FREQUENCY	1 MHz
LOWER -3 dB FREQUENCY	DC
AC-GND-DC + INPUT	GND
AC-GND-DC -INPUT	DC
STEP ATTEN DC BAL	Adjusted for DC balance
DC OFFSET COARSE	Midrange
DC OFFSET FINE	Midrange
CURRENT-VOLTS	VOLTS

Set the Time Base controls:

Time/Div	.5 ms
Variable	Calib
Slope	+
Coupling	AC
Source	Int
Trigger Mode	Auto

21. Check or Adjust — INPUT Attenuator Shunt Compensation ①

- a. Test equipment is shown in Fig. 5-27.
- b. Connect a 47 μ s RC Normalizer to the -INPUT of the Type 3A9.
- c. Connect a coaxial cable between the Standard Amplitude Calibrator Output connector and the RC Normalizer.
- d. Set the Standard Amplitude Calibrator Amplitude to .5 volts.
- e. CHECK—The display for optimum square wave as shown in Fig. 5-27, using the Standard Amplitude Calibrator Amplitude and Type 3A9 VOLTS/DIV settings listed in Table 5-8.
- f. ADJUST—C205B, C207B and C209B (see Fig. 5-20) for the best flat bottom on the square waves, as shown in Fig. 5-28.

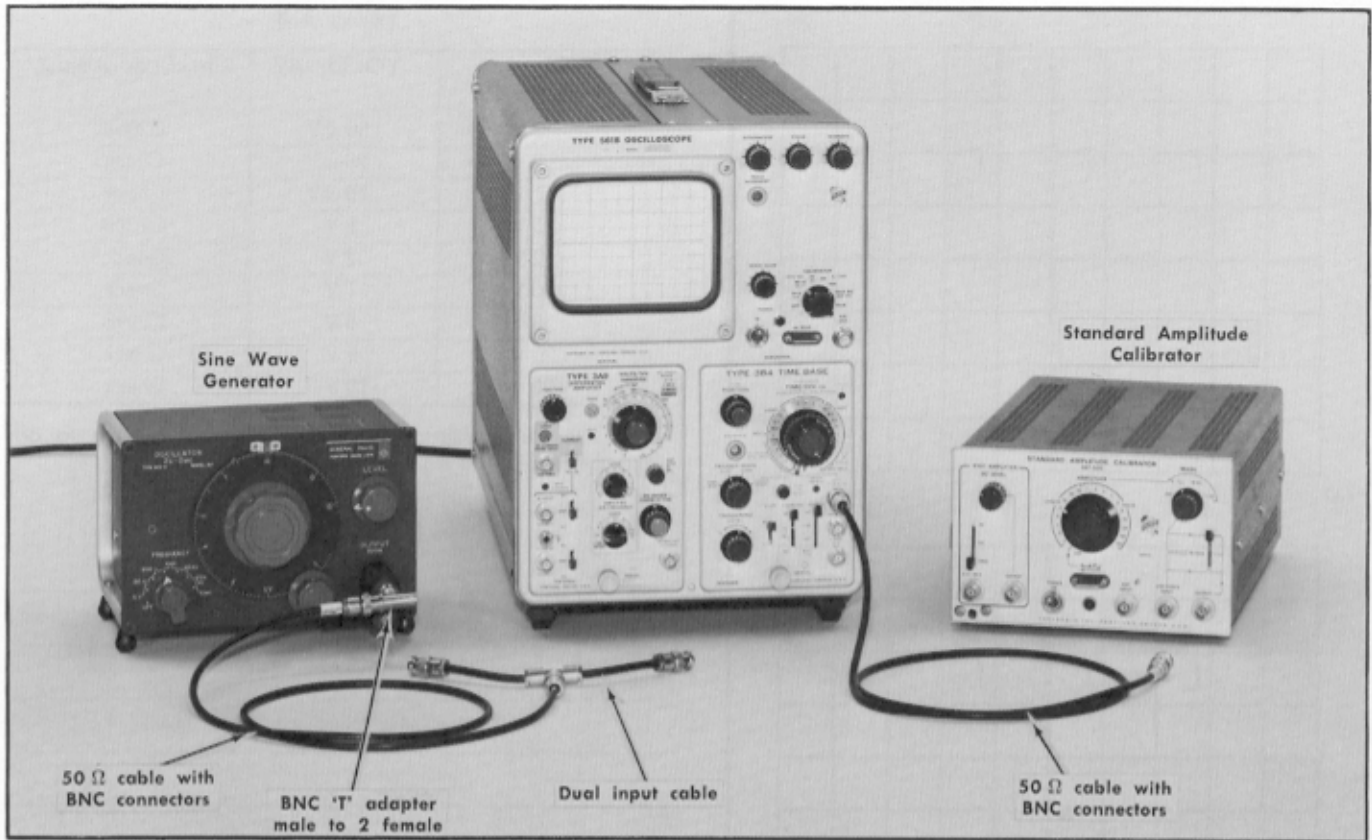

Fig. 5-29. Equipment required for steps 22 through 24.

Set the Type 3A9 controls:

VOLTS/DIV	.1 mV
VARIABLE	CAL
POSITION	Midrange
UPPER -3 dB FREQUENCY	1 MHz
LOWER -3 dB FREQUENCY	DC
AC-GND-DC +INPUT	GND
AC-GND-DC -INPUT	GND
STEP ATTEN DC BAL	Adjusted for DC balance
DC OFFSET COARSE	Midrange
DC OFFSET FINE	Midrange
CURRENT-VOLTS	VOLTS

Set the Time Base controls:

Time/Div	Ext Horiz In
Variable	Calib
Horiz Volts/Div	2 (pull to unlock)

22. Check 100 Hz CMRR

- a. Test equipment is shown in Fig. 5-29.
- b. Connect a coaxial cable between the Standard Amplitude Calibrator Output and the Time Base Ext Horiz In.
- c. Set the Standard Amplitude Calibrator Output Amplitude at 20 volts (square wave).
- d. Adjust the Time Base Horizontal Volts/Div Variable for exactly 10 divisions of horizontal deflection (two dots). Leave Variable in this position for the balance of the test. Horizontal is now adjusted for 2 volts per divisions. See Fig. 5-30A.
- e. Disconnect the coaxial cable from the Standard Amplitude Calibrator.
- f. Connect a 100 Hz signal from the Sine Wave Generator, through a BNC T connector, coaxial cable and dual input cable to the Type 3A9 +INPUT and -INPUT connectors.
- g. Connect a coaxial cable, from the BNC T connector at the Sine Wave Generator, to the Time Base Ext Horiz In.

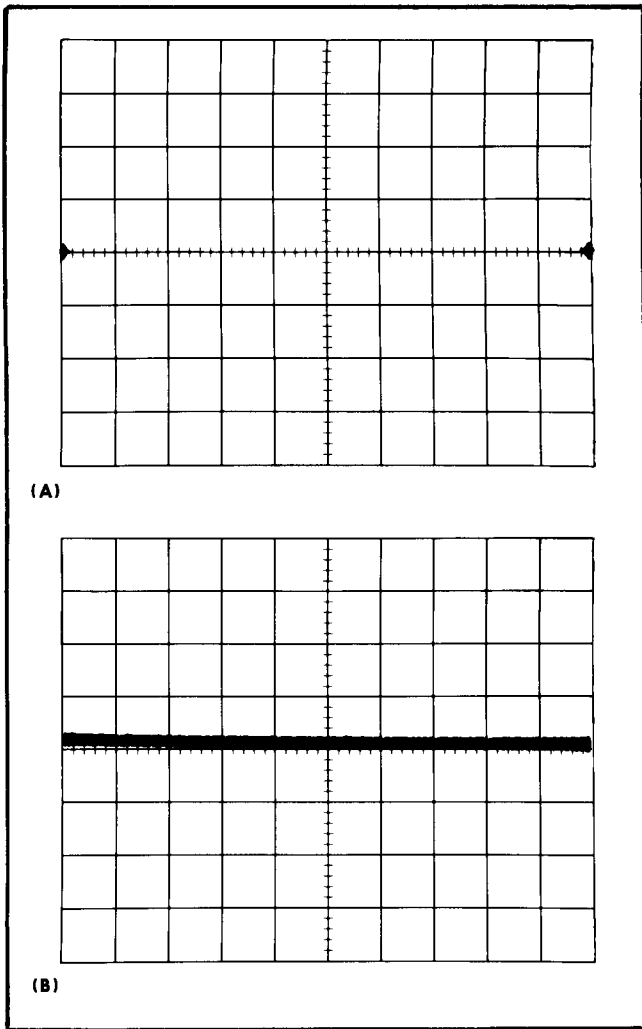

Fig. 5-30. Typical display showing (A) deflection with Horizontal Volts/Div at 2 and (B) typical display of tilt.

h. Adjust the Sine Wave Generator Level control for an output which gives 10 divisions of horizontal display.

i. Set both Type 3A9 AC-GND-DC switches (+ and -) to DC.

j. CHECK—The horizontal display for vertical tilt. (Vertical deflection of the tilt should not exceed 2 div. See Fig. 5-30B. The 2 div requirement at .1 mV/DIV is equivalent to a CMRR of 100,000:1; 2 div at .1 mV/div = .2 mV; 20 V divided by .2 mV = 100,000).

23. Check AC Coupled CMRR at 60 Hz

- Set both AC-GND-DC switches to GND.
- Set the Sine Wave Generator frequency to 60 Hz.
- Adjust the Generator Level to give exactly 10 divisions of horizontal deflection.
- Set the Type 3A9 VOLTS/DIV switch to 10 mV.

- Set both AC-GND-DC switches to AC.
- CHECK—The vertical deflection of the display should not exceed 1 div (CMRR = 2,000:1 or higher).
- Set both AC-GND-DC switches to GND.

24. Check or Adjust 100 kHz, Check 1 kHz **Ⓢ** CMRR

- Set the Sine Wave Generator frequency at 100 kHz.
- Set the Type 3A9 VOLTS/DIV switch to .1 mV.
- Adjust the Generator Level to give exactly 10 divisions of horizontal deflection.
- Simultaneously set both AC-GND-DC switches to DC.
- CHECK—The display tilt and vertical deflection should not exceed 2 divisions.
- ADJUST—C162, HF CMRR, Fig. 5-20, for minimum vertical deflection.
- Set both AC-GND-DC switches to GND.
- Set the Type 3A9 VOLTS/DIV switch to .5 mV.
- Set both AC-GND-DC switches to AC.
- CHECK—The vertical deflection of the display should not exceed 2 divisions.
- Set both AC-GND-DC switches to GND.
- Set the VOLTS/DIV switch to 20 mV.
- Set both AC-GND-DC switches to AC.
- CHECK—The vertical deflection of the display should not exceed 2.2 divisions.
- Set both AC-GND-DC switches to GND and then simultaneously set them to DC.
- CHECK—The vertical deflection should not exceed 2 divisions.
- Set both AC-GND-DC switches to GND.
- Set the Sine Wave Generator frequency to 1 kHz.
- Set both AC-GND-DC switches to AC.
- CHECK—The vertical deflection should not exceed 1.1 divisions.
- Set both AC-GND-DC switches to GND and then to DC.
- CHECK—The vertical deflection of the display should not exceed 1 division.¹
- Disconnect all cables from the Type 3A9 INPUTS and the Time Base. Return the Time Base Time/Div to .1 μs.

¹If CMRR is not within tolerance at 100 kHz and 1 kHz, C205 may be adjusted at 100 kHz and R205E at 1 kHz for minimum vertical deflection.

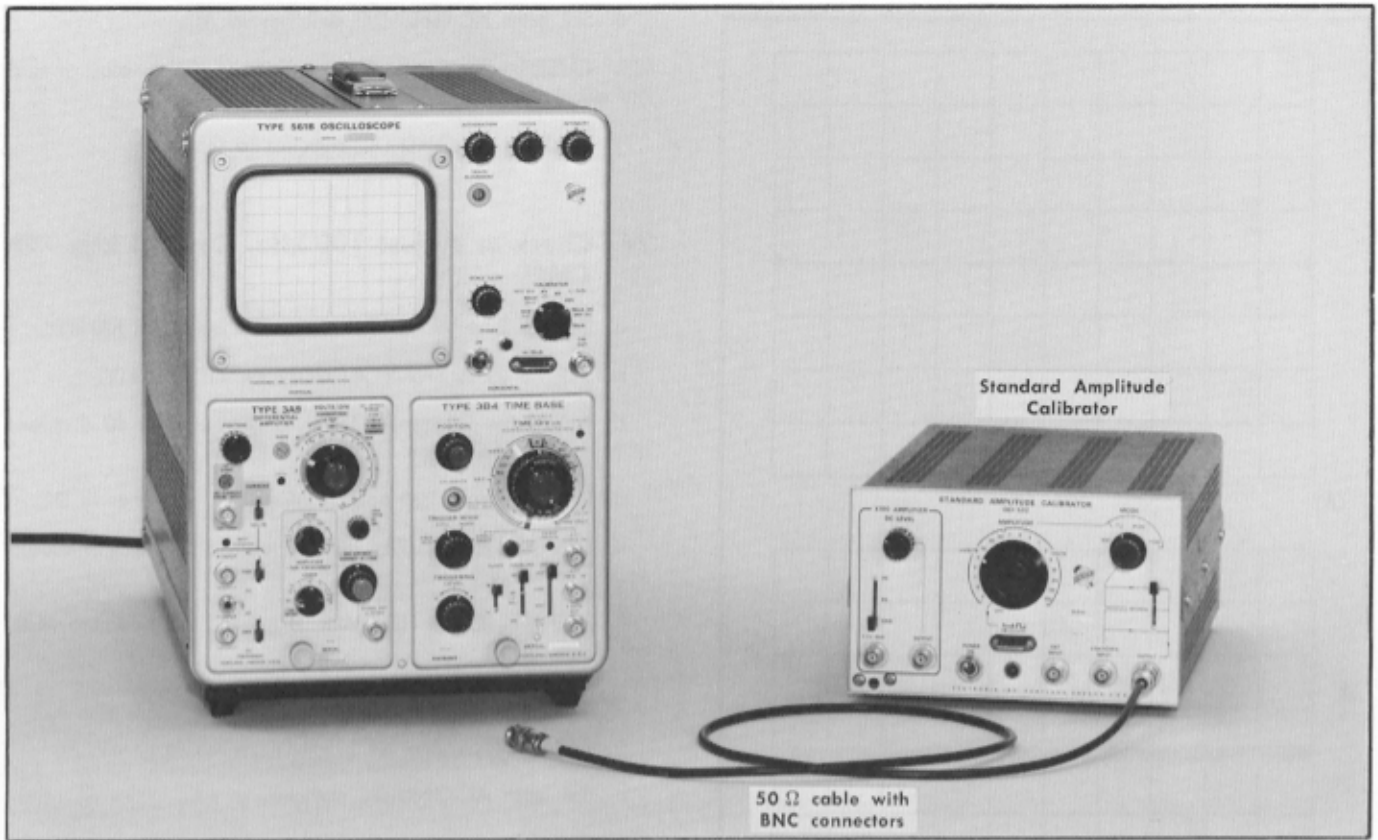

Fig. 5-31. Equipment required for step 25.

Set the Type 3A9 controls:

VOLTS/DIV	1 mV
VARIABLE	CAL
POSITION	Midrange
UPPER —3 dB FREQUENCY	1 MHz
LOWER — 3 dB	DC OFFSET
FREQUENCY	
AC-GND-DC +INPUT	DC
AC-GND-DC —INPUT	GND
STEP ATTEN DC BAL	Adjusted for DC balance
CURRENT-VOLTS	VOLTS

Set the Time Base controls:

Time/Div	1 ms
Variable	Calib
Slope	+
Coupling	AC
Source	Int
Trigger Mode	Auto

25. Check Isolation Between + and — Inputs

- a. Test equipment is shown in Fig. 5-31.
- b. Connect a cable between the Standard Amplitude Calibrator Output and the Type 3A9 +INPUT.
- c. Set the Standard Amplitude Calibrator Amplitude to .1 volt square wave.
- d. Adjust DC OFFSET COARSE and FINE to position the top of the square wave to the graticule center line.
- e. Switch the —AC-GND-DC switch to DC.
- f. CHECK—Trace deflection must be 0.5 division or less.
- g. Repeat the above procedure for the —INPUT, checking for trace deflection when switching the +AC-GND-DC switch to DC.

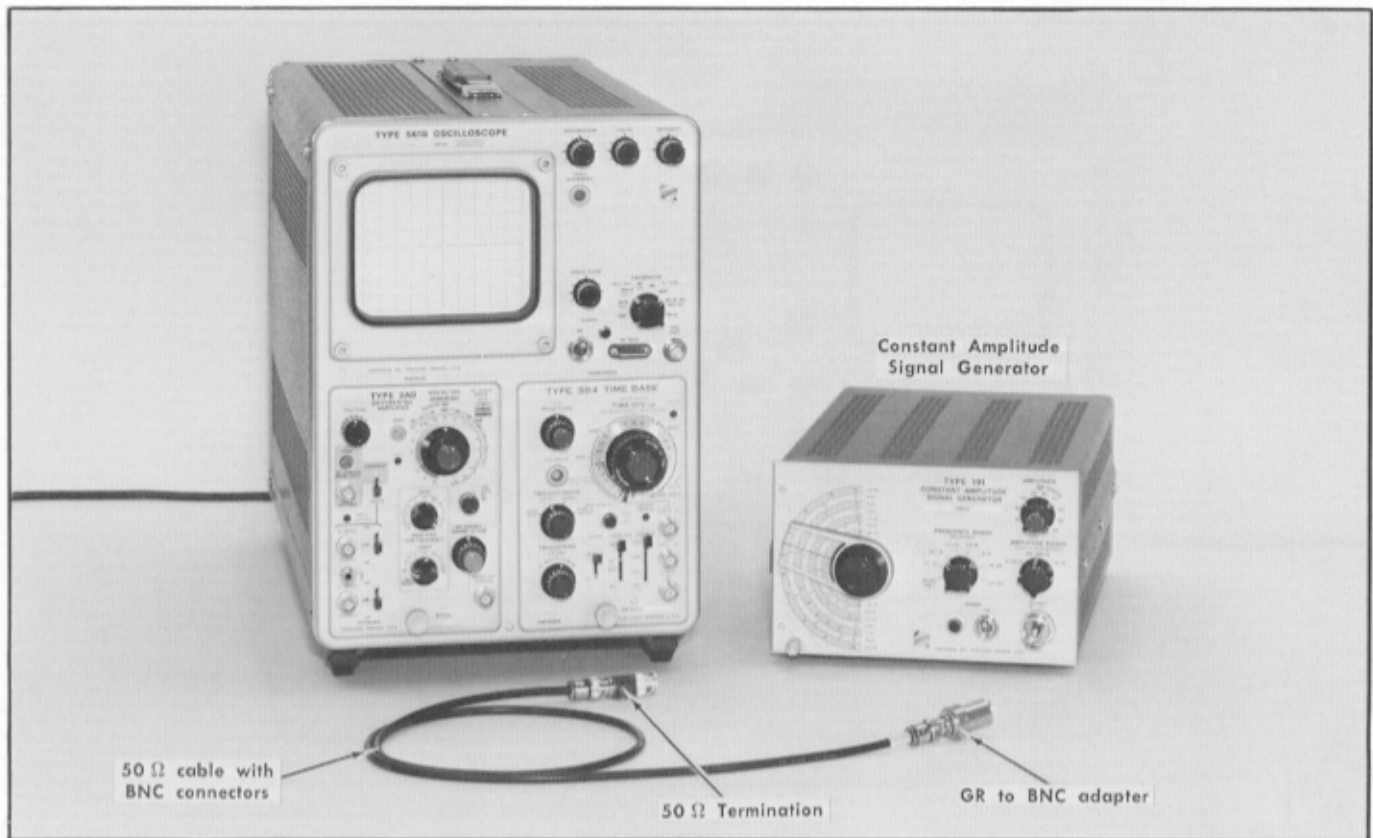

Fig. 5-32. Equipment required for step 26.

Set the Type 3A9 controls:

VOLTS/DIV	1 mV
VARIABLE	CAL
POSITION	Midrange
UPPER -3 dB FREQUENCY	1 MHz
LOWER -3 dB FREQUENCY	DC
AC-GND-DC +INPUT	DC
AC-GND-DC -INPUT	GND
STEP ATTEN DC BAL	Adjusted for DC balance
CURRENT-VOLTS	VOLTS

Set the Time Base controls:

Time/Div	.1 ms
Variable	Calib
Slope	+
Coupling	AC
Source	Int
Trigger Mode	Auto

26. Check Amplifier Frequency Response

a. Test equipment is shown in Fig. 5-32.

b. Connect a GR to BNC female adapter to the Constant Amplitude Signal Generator Output. Connect a cable to the GR to BNC adapter. Connect a 50 Ω termination to the end of the cable and attach the termination to the Type 3A9 +INPUT.

c. Set the Constant Amplitude Signal Generator as follows:

Frequency Range	50 kHz Only
Amplitude Range	5-50 mV
Amplitude	5 mV

d. Observe a 5 division display (sine wave) on the graticule.

e. Set the Constant Amplitude Generator Frequency Range to .75-1.6 MHz.

f. Set the Variable Frequency control to 1 on the .75-1.6 scale.

g. CHECK—The display amplitude for 3.5 divisions or greater.

h. Set the Variable Frequency control to 1.3 on the .75 to 1.6 scale.

i. CHECK—The display amplitude for 3.5 divisions or less.

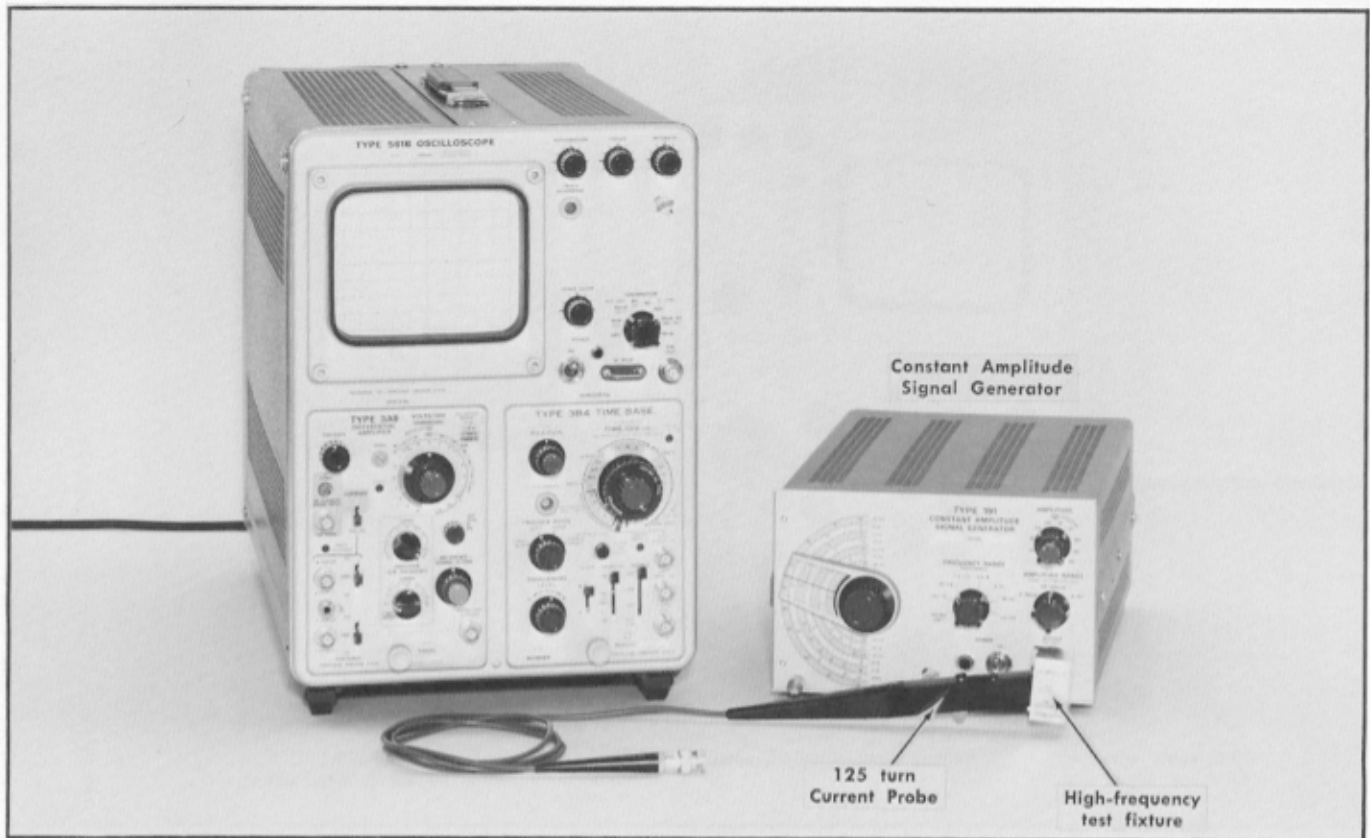

Fig. 5-33. Equipment required for step 27.

Set the Type 3A9 controls:

CURRENT/DIV	10 mA
VARIABLE	CAL
POSITION	Midrange
UPPER -3 dB FREQUENCY	1 MHz
LOWER -3 dB FREQUENCY	DC
AC-GND-DC + INPUT	GND
AC-GND-DC -INPUT	GND
STEP ATTEN DC BAL	Adjusted for DC balance
CURRENT-VOLTS	CURRENT

Set the Time Base controls:

Time/Div	.1 ms
Variable	Calib
Slope	+
Coupling	AC
Source	Int
Trigger Mode	Auto

27. Current Probe Input Frequency Response

a. Test equipment is shown in Fig. 5-33.

b. Connect a High Frequency Current Test Fixture to the Constant Amplitude Signal Generator Output.

c. Connect a 125 turn current probe (P6019, P6042) to the Current Test Fixture.

d. Connect the Current Probe to the Type 3A9 AC CURRENT PROBE INPUT.

e. Set the Constant Amplitude Signal Generator controls as follows:

Amplitude Range	.5-5 V
Amplitude	20

f. Observe a 4 division sine wave display on the Type 561B graticule.

g. Switch the Constant Amplitude Signal Generator Frequency Range to .75-1.6 MHz.

h. Set the Frequency variable to 1 MHz.

i. CHECK—The display should have an amplitude of not less than 2.8 divisions.

j. Set the Frequency variable to 1.3 MHz.

k. CHECK—The display should have an amplitude of not greater than 2.8 divisions.

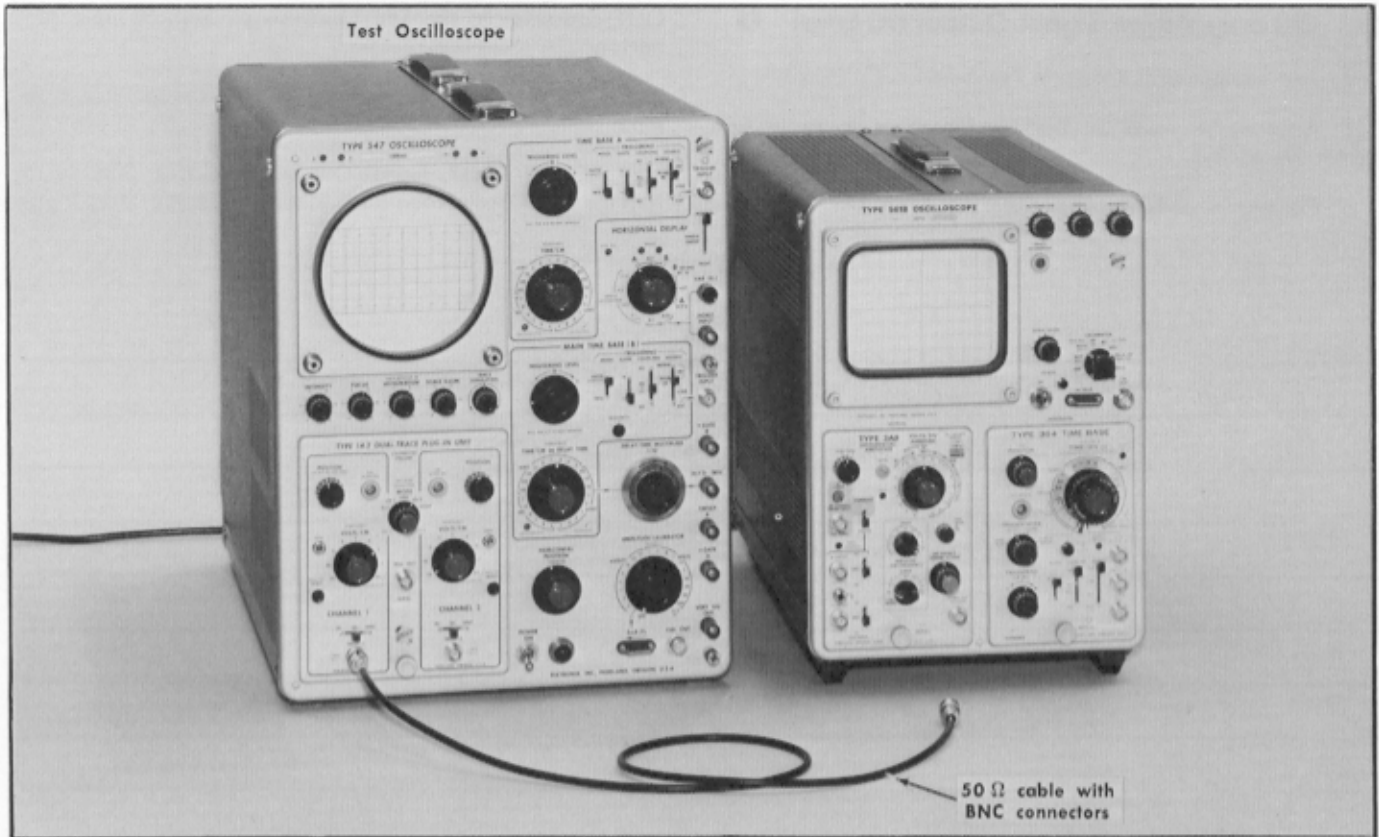

Fig. 5-34. Equipment required for step 28.

Set the Type 3A9 controls:

VOLTS/DIV	10 mV
VARIABLE	CAL
POSITION	Midrange
UPPER -3 dB FREQUENCY	1 MHz
LOWER -3 dB FREQUENCY	DC
AC-GND-DC +INPUT	GND
AC-GND-DC -INPUT	GND
STEP ATTEN DC BAL	Adjust for DC balance
DC OFFSET COARSE	Midrange
DC OFFSET FINE	Midrange
CURRENT-VOLTS	VOLTS

Set the Time Base controls:

Time/Div	.5 ms
Variable	Calib
Slope	+
Coupling	AC
Source	Int
Trigger Mode	Free Run

Set the Test Oscilloscope controls:

Volts/Div	.2 V
Vertical Input Coupling	DC
Time Base Time/Div	.5 ms
Triggering Mode	Free Run

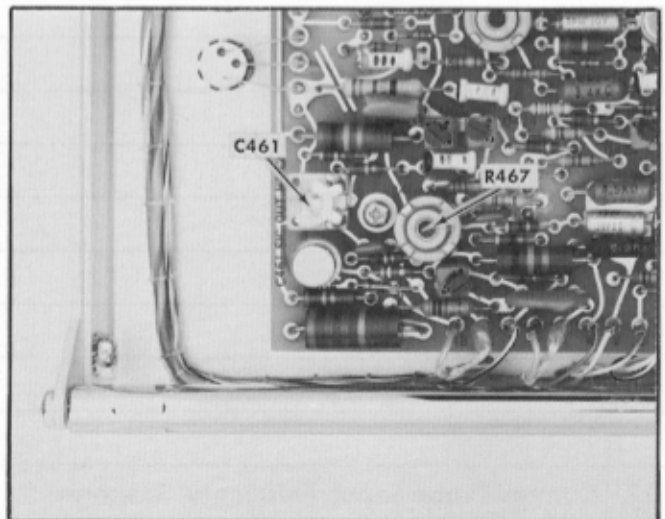

Fig. 5-35. Location of controls.

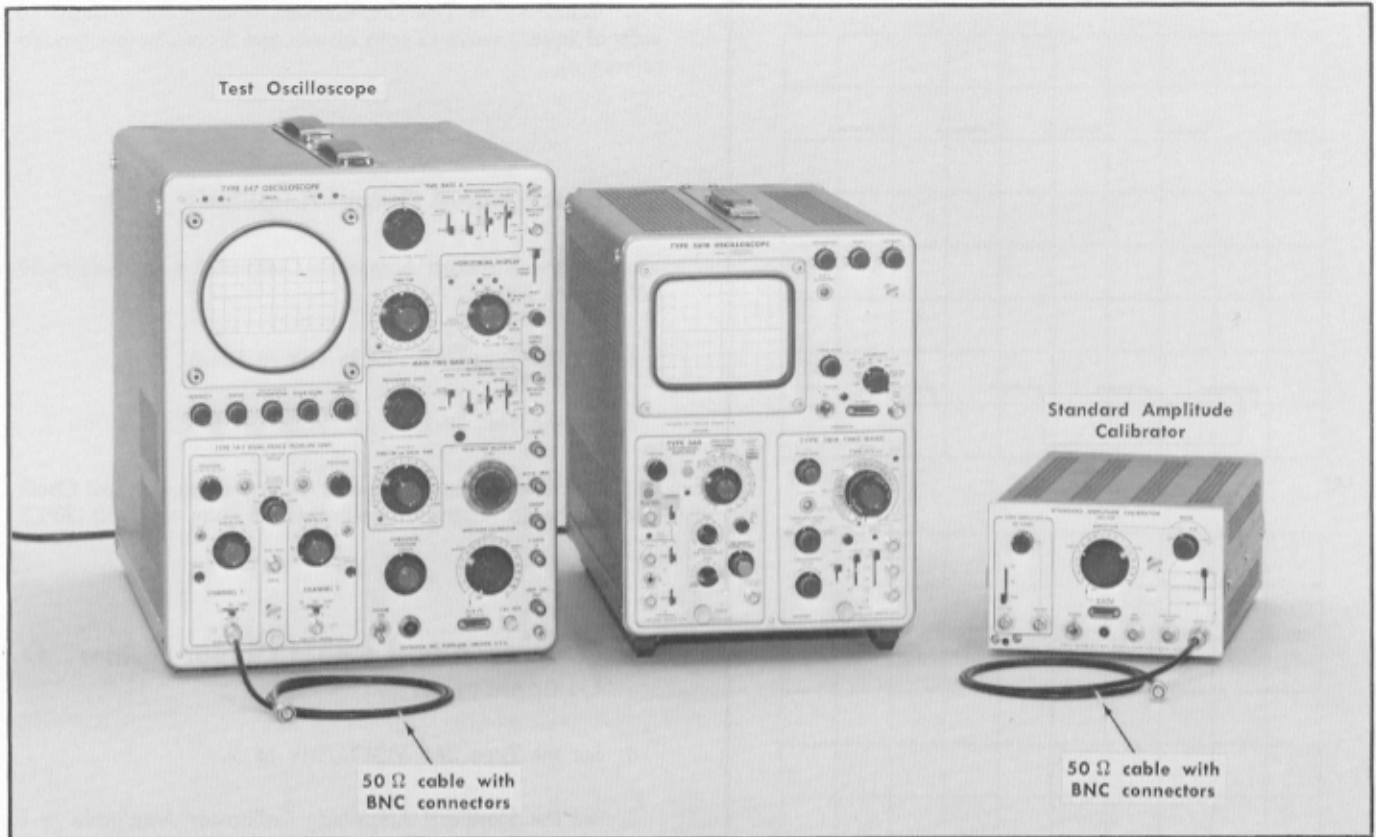

Fig. 5-36. Equipment required for steps 29 through 31.

Set the Type 3A9 controls:

VOLTS/DIV	.2 V
VARIABLE	CAL
POSITION	Midrange
UPPER -3 dB FREQUENCY	1 MHz
LOWER -3 dB FREQUENCY	DC
AC-GND-DC +INPUT	AC
AC-GND-DC -INPUT	GND
STEP ATTEN DC BAL	Adjusted for DC balance
CURRENT-VOLTS	VOLTS

Set the Time Base controls:

Time/Div	1 ms
Variable	Calib
Slope	+
Coupling	AC
Source	Int
Trigger Mode	Auto

Set the Test Oscilloscope controls:

Volts/Div	5
Input Coupling	DC
Time/Div	.1 ms
Triggering	Auto, +AC, Int

29. Check Signal Output Dynamic Range

- Test equipment is shown in Fig. 5-36.
- Connect the Standard Amplitude Calibrator to the Type 3A9 +INPUT.
- Set the Standard Amplitude Calibrator Amplitude to 10 volts, Mode to Square Wave.
- Connect a cable between the Type 3A9 SIGNAL OUT to the Test oscilloscope Input.
- Switch the Type 3A9 +AC-GND-DC switch to DC.

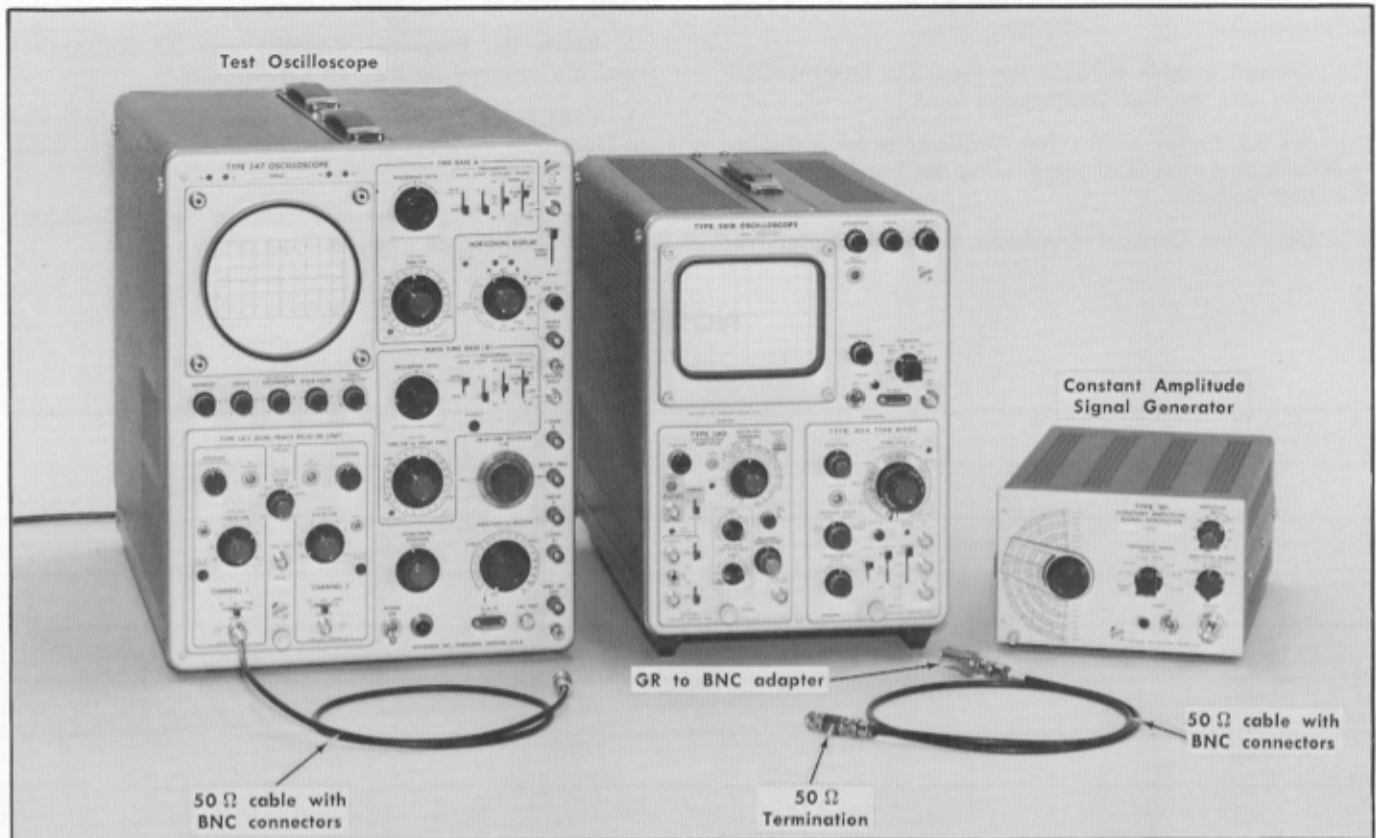

Fig. 5-38. Equipment required for step 32.

Set the Type 3A9 controls:

VOLTS/DIV	10 mV
VARIABLE	CAL
POSITION	Midrange
UPPER -3 dB FREQUENCY	1 MHz
LOWER -3 dB FREQUENCY	DC
AC-GND-DC +INPUT	DC
AC-GND-DC -INPUT	GND
STEP ATTEN DC BAL	Adjusted for DC balance
CURRENT-VOLTS	VOLTS

Set the Time Base controls:

Time/Div	.1 ms
Variable	Calib
Slope	+
Coupling	AC
Source	Int
Trigger Mode	Auto

Set the Test Oscilloscope controls:

Volts/Div	1 V
Variable	Calib

Input Coupling	DC
Time/Div	1 ms
Slope	+
Coupling	AC
Source	Int
Trigger Mode	Auto

32. Check Signal Output Frequency Response

- Test equipment is shown in Fig. 5-38.
- Connect a GR to BNC female adapter to the Constant Amplitude Signal Generator Output.
- Connect a cable with BNC connectors to the GR to BNC adapter.
- Connect a 50 Ω termination to the cable.
- Connect the termination to the Type 3A9 +INPUT.
- Set the Constant Amplitude Signal Generator controls as follows:

Amplitude Range	50-500 mV
Amplitude	5
Frequency Range	50 kHz only
Frequency Variable	.75

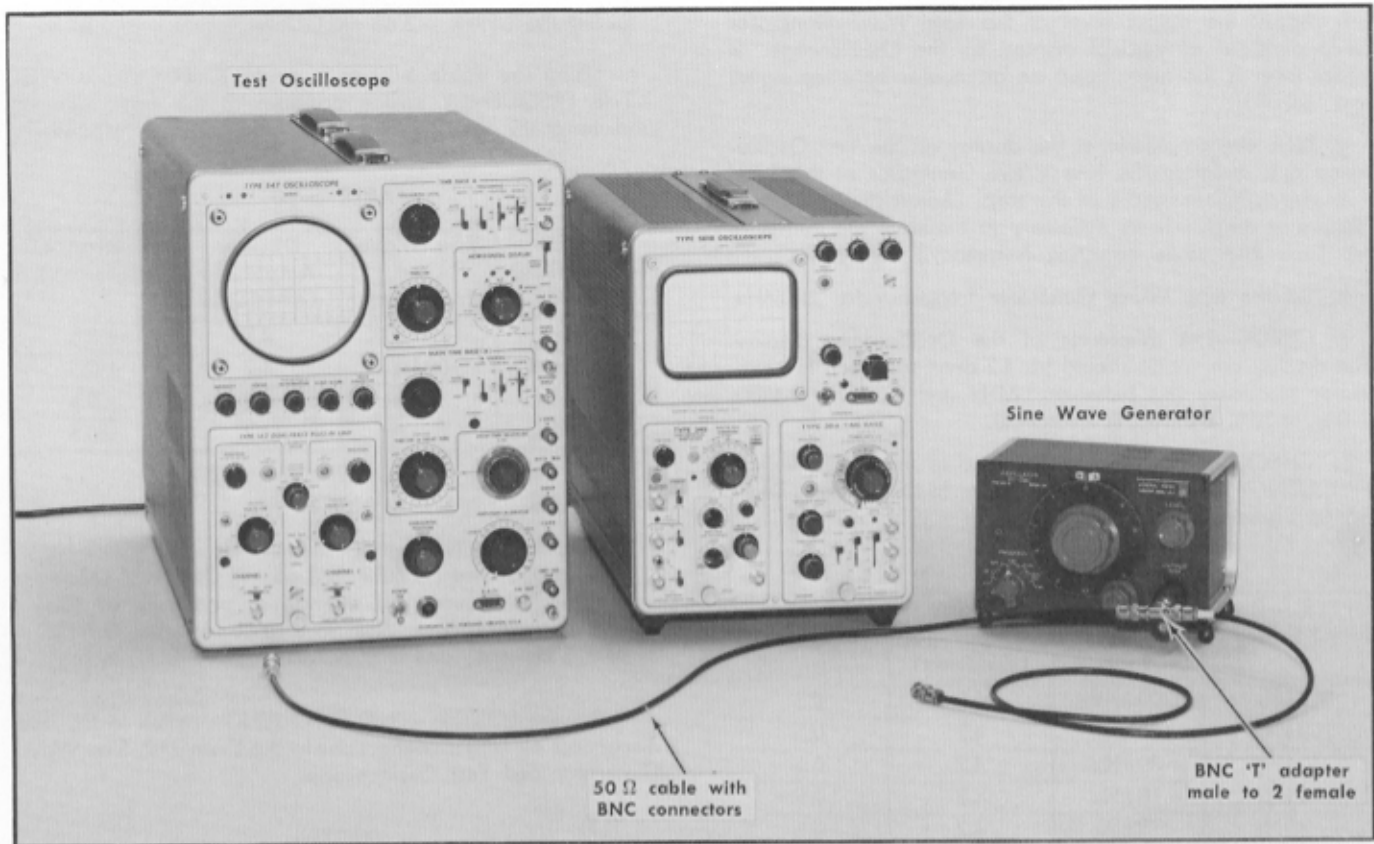

Fig. 5-39. Equipment required for step 33.

Set the Type 3A9 controls:

VOLTS/DIV	10 mV
VARIABLE	CAL
POSITION	Midrange
UPPER —3 dB FREQUENCY	1 MHz
LOWER —3 dB FREQUENCY	DC
AC-GND-DC +INPUT	DC
AC-GND-DC —INPUT	DC
STEP ATTEN DC BAL	Adjusted for DC balance
DC OFFSET COARSE	Midrange
DC OFFSET FINE	Midrange
CURRENT-VOLTS	VOLTS

Set the Time Base controls:

Time/Div	1 ms
Variable	Calib
Slope	+
Coupling	AC
Source	Int
Trigger Mode	Auto

Set the Test Oscilloscope controls:

Time/Div	5 μ s
Variable	Cal
Volts/Div	10 mV
Trigger Mode	Free Run

NOTE

Since the Test Oscilloscope is used only to monitor the Sine Wave Generator amplitude, vertical Volts/Div and horizontal Time/Div may be set at any convenient position.

33. Check Upper and Lower —3 dB Frequencies

- Test equipment is shown in Fig. 5-39.
- Connect a BNC T connector to the Sine Wave Generator output connector.
- Connect a coaxial cable between the signal T connector and the Type 3A9 +INPUT.
- Connect a coaxial cable between the signal T connector and the Test Oscilloscope vertical Input connector.
- Set the frequency of the Sine Wave Generator to 1 kHz.

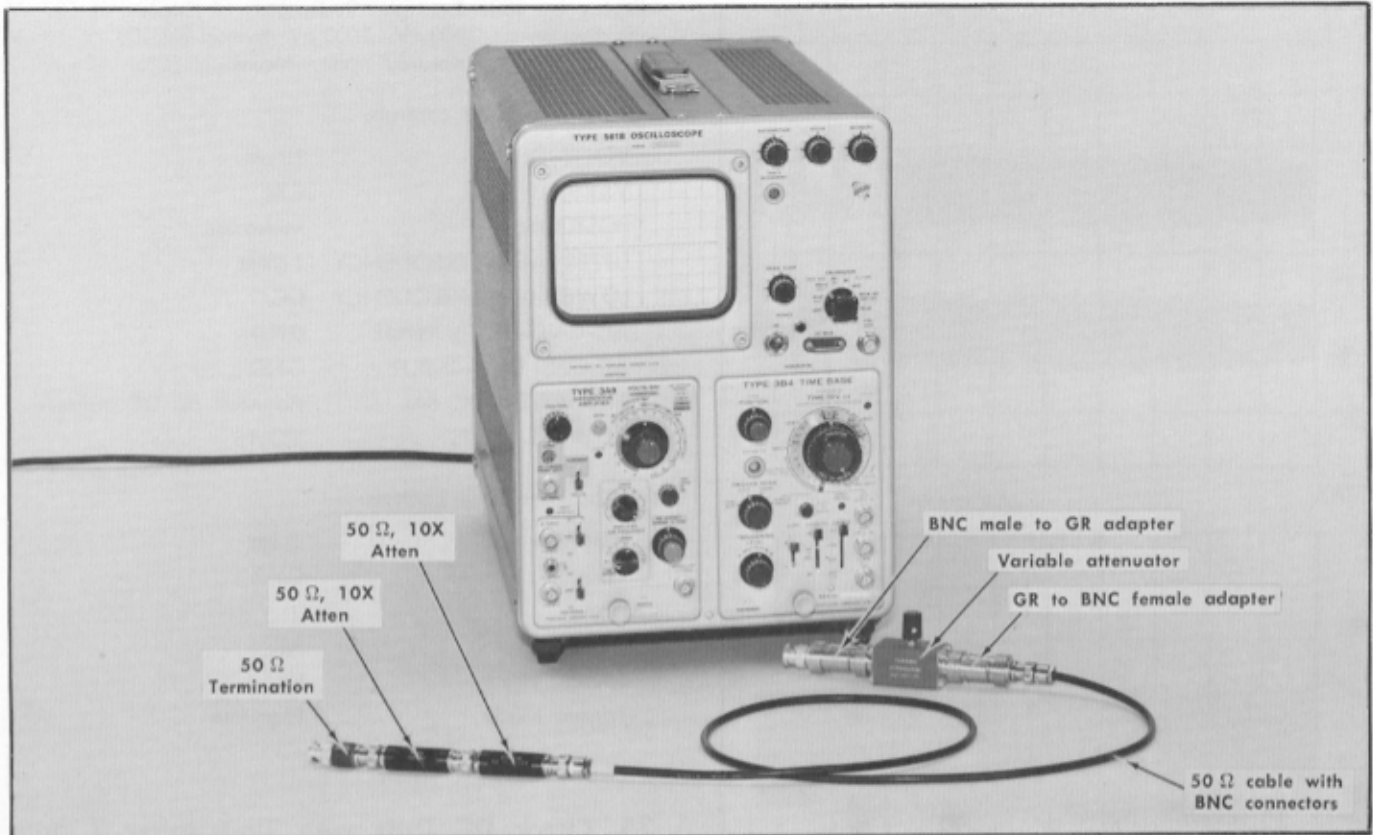

Fig. 5-40. Equipment required for step 34.

Set the Type 3A9 controls:

VOLTS/DIV	10 μV
VARIABLE	CAL
POSITION	Midrange
UPPER -3 dB FREQUENCY	1 MHz
LOWER -3 dB FREQUENCY	DC
AC-GND-DC +INPUT	DC
AC-GND-DC -INPUT	GND
STEP ATTEN DC BAL	Adjusted for DC balance
DC OFFSET COARSE	Midrange
DC OFFSET FINE	Midrange
CURRENT-VOLTS	VOLTS

Set the Time Base controls:

Time/Div	.5 μs
Variable	Calib
Slope	+
Coupling	AC
Source	Int
Trigger Mode	Free Run

34. Check Overall Noise Level Tangentially

a. Test equipment is shown in Fig. 5-40.

b. Connect a 50 Ω termination to the Type 3A9 +INPUT connector. Connect two 10 \times attenuators (50 Ω) to the 50 Ω termination.

c. Connect a GR to BNC male adapter to the Oscilloscope Cal Out connector. Connect the Variable Attenuator to the GR connector (arrow on Attenuator pointing away from the oscilloscope).

d. Connect a GR to BNC female adapter to the variable Attenuator.

e. Connect the 50 Ω cable (from the Type 3A9) to the GR to BNC adapter.

f. Set the Oscilloscope Calibrator output amplitude to 40 mV.

g. Turn the variable Attenuator control fully clockwise.

h. Observe two noise bands displayed on the CRT (noise and free running square wave). See Fig. 5-41A.

i. Rotate the variable Attenuator control slowly counter-clockwise until the two noise bands merge (just to the point at which the dark band between the two noise bands disappears). See Fig. 5-41B.

j. Remove the two 10 \times Attenuators and connect the coaxial cable to the 50 Ω termination.

k. Switch the Type 3A9 VOLTS/DIV switch to any position which will give a convenient display (two traces).

Performance Check/Calibration—Type 3A9

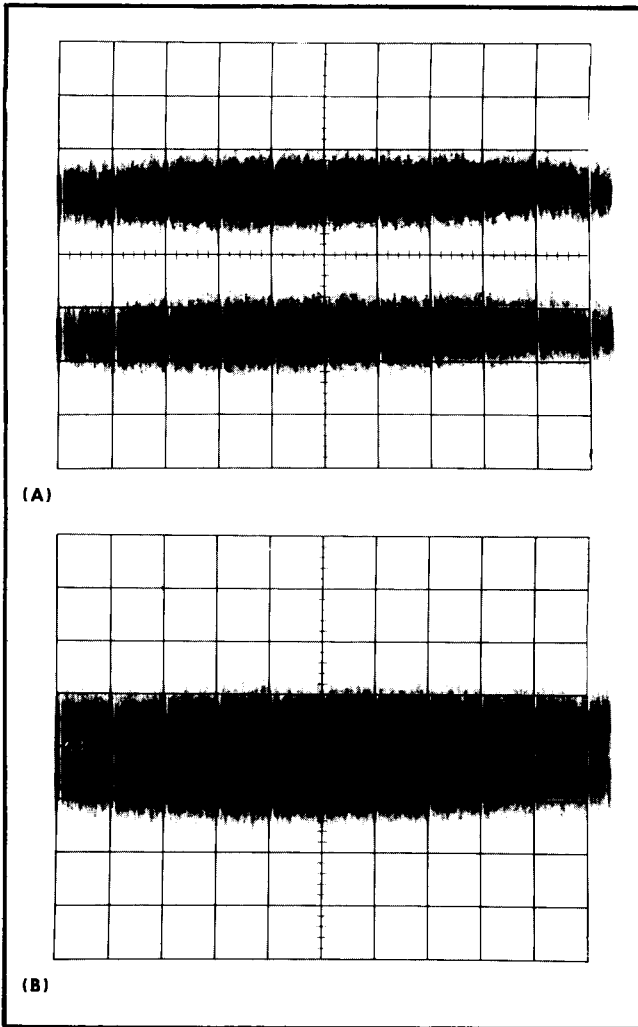

Fig. 5-41. Typical display showing (A) two noise bands and (B) merging noise bands.

1. CHECK—The vertical amplitude of the display. Calculate the tangentially measured noise by dividing the measured

display by 100. Example: 2 divisions of display at $500 \mu\text{V}$ per division = $1000 \mu\text{V}$. $1000 \mu\text{V}$ divided by 100 = $10 \mu\text{V}$ of tangentially measured noise. Maximum noise, $12 \mu\text{V}$.

Set the Type 3A9 controls:

VOLTS/DIV	10 μV
VARIABLE	CAL
POSITION	Midrange
UPPER —3 dB FREQUENCY	1 MHz
LOWER —3 dB FREQUENCY	DC
AC-GND-DC + INPUT	GND
AC-GND-DC —INPUT	GND
STEP ATTEN DC BAL	Adjusted for DC balance
CURRENT-VOLTS	VOLTS

Set the Time Base controls:

Time/Div	.5 ms
Variable	Calib
Slope	+
Coupling	AC
Source	Int
Trigger Mode	Free Run

35. Check DC Drift with Time (after 1 hour warmup. Ambient temperature and Line Voltage must be held constant).

- a. No test equipment required.
- b. Position the trace to graticule center using the POSITION control.
- c. CHECK—The trace drift for 1 minute. Drift must be 0.5 division or less.
- d. CHECK—Trace drift for 1 hour. Drift must be 1.0 division or less.

NOTES

PARTS LIST ABBREVIATIONS

BHB	binding head brass	int	internal
BHS	binding head steel	lg	length or long
cap.	capacitor	met.	metal
cer	ceramic	mtg hdw	mounting hardware
comp	composition	OD	outside diameter
conn	connector	OHB	oval head brass
CRT	cathode-ray tube	OHS	oval head steel
csk	countersunk	PHB	pan head brass
DE	double end	PHS	pan head steel
dia	diameter	plstc	plastic
div	division	PMC	paper, metal cased
elect.	electrolytic	poly	polystyrene
EMC	electrolytic, metal cased	prec	precision
EMT	electrolytic, metal tubular	PT	paper, tubular
ext	external	PTM	paper or plastic, tubular, molded
F & I	focus and intensity	RHB	round head brass
FHB	flat head brass	RHS	round head steel
FHS	flat head steel	SE	single end
Fil HB	fillister head brass	SN or S/N	serial number
Fil HS	fillister head steel	SW	switch
h	height or high	TC	temperature compensated
hex.	hexagonal	THB	truss head brass
HHB	hex head brass	thk	thick
HHS	hex head steel	THS	truss head steel
HSB	hex socket brass	tub.	tubular
HSS	hex socket steel	var	variable
ID	inside diameter	w	wide or width
incd	incandescent	WW	wire-wound

PARTS ORDERING INFORMATION

Replacement parts are available from or through your local Tektronix, Inc. Field Office or representative.

Changes to Tektronix instruments are sometimes made to accommodate improved components as they become available, and to give you the benefit of the latest circuit improvements developed in our engineering department. It is therefore important, when ordering parts, to include the following information in your order: Part number, instrument type or number, serial or model number, and modification number if applicable.

If a part you have ordered has been replaced with a new or improved part, your local Tektronix, Inc. Field Office or representative will contact you concerning any change in part number.

SPECIAL NOTES AND SYMBOLS

- ×000 Part first added at this serial number
- 00× Part removed after this serial number
- *000-0000-00 Asterisk preceding Tektronix Part Number indicates manufactured by or for Tektronix, Inc., or reworked or checked components.
- Use 000-0000-00 Part number indicated is direct replacement.
- ⓘ Screwdriver adjustment.
- Control, adjustment or connector.

SECTION 6

ELECTRICAL PARTS LIST

Values are fixed unless marked Variable.

Ckt. No.	Tektronix Part No.	Serial/Model No. Eff	Disc	Description		
Bulbs						
B174	150-0035-00			Neon, A1D T2		
B535	150-0035-00			Neon, A1D T2		
Capacitors						
Tolerance $\pm 20\%$ unless otherwise indicated.						
C101	281-0518-00		47 pF	Cer	500 V	
C102 ¹	*295-0081-00		0.1 μ F	MT	600 V	10%
C105A	281-0505-00		12 pF	Cer	500 V	10%
C105B	281-0081-00		1.8-13 pF, Var	Air		
C105C	281-0078-00		1.4-7.3 pF, Var	Air		
C105D	283-0638-00		130 pF	Mica	100 V	1%
C107A	281-0505-00		12 pF	Cer	500 V	10%
C107B	281-0081-00		1.8-13 pF, Var	Air		
C107C	281-0078-00		1.4-7.3 pF, Var	Air		
C107D	285-0813-00		0.0015 μ F	MT	100 V	5%
C109A	281-0505-00		12 pF	Cer	500 V	10%
C109B	281-0081-00		1.8-13 pF, Var	Air		
C109C	281-0078-00		1.4-7.3 pF, Var	Aii		
C109D	285-0814-00		0.015 μ F	MT	100 V	5%
C111	281-0658-00		6.2 pF	Cer	500 V	± 0.25 pF
C112	281-0081-00		1.8-13 pF, Var	Air		
C131	281-0080-00		1.7-11 pF, Var	Air		
C143	281-0504-00		10 pF	Cer	500 V	10%
C158	283-0594-00		0.001 μ F	Mica	100 V	1%
C162	281-0077-00		1.3-5.4 pF, Var	Air		
C164	283-0003-00		0.01 μ F	Cer	150 V	
C176	285-0815-00		1 μ F	MT	100 V	5%
C201	281-0518-00		47 pF	Cer	500 V	
C202 ¹	*295-0081-00		0.1 μ F	MT	600 V	10%
C205A	281-0505-00		12 pF	Cer	500 V	10%
C205B	281-0081-00		1.8-13 pF, Var	Air		
C205C	281-0078-00		1.4-7.3 pF, Var	Air		
C205D	283-0638-00		130 pF	Mica	100 V	1%
C207A	281-0505-00		12 pF	Cer	500 V	10%
C207B	281-0081-00		1.8-13 pF, Var	Air		

¹C102 and C202 matched within $\pm 1\%$ of each other. Furnished as a unit.

Electrical Parts List—Type 3A9

Capacitors (cont)

Ckt. No.	Tektronix Part No.	Serial/Model No. Eff	Disc	Description		
C207C	281-0078-00		1.4-7.3 pF, Var	Air		
C207D	285-0813-00		0.0015 μ F	MT	100 V	5%
C209A	281-0505-00		12 pF	Cer	500 V	10%
C209B	281-0081-00		1.8-13 pF, Var	Air		
C209C	281-0078-00		1.4-7.3 pF, Var	Air		
C209D	285-0814-00		0.015 μ F	MT	100 V	5%
C211	281-0658-00		6.2 pF	Cer	500 V	± 0.25 pF
C212	281-0081-00		1.8-13 pF, Var	Air		
C231	281-0080-00		1.7-11 pF, Var	Air		
C243	281-0504-00		10 pF	Cer	500 V	10%
C258	283-0594-00		0.001 μ F	Mica	100 V	1%
C273	290-0305-00		3 μ F	Elect.	150 V	
C275	290-0297-00		39 μ F	Elect.	10 V	10%
C276	285-0815-00		1 μ F	MT	100 V	5%
C283	281-0504-00		10 pF	Cer	500 V	10%
C285	290-0297-00		39 μ F	Elect.	10 V	10%
C295	290-0135-00		15 μ F	Elect.	20 V	
C336	283-0059-00		1 μ F	Cer	25 V	+80%—20%
C337	290-0305-00		3 μ F	Elect.	150 V	
C355	290-0309-00		100 μ F	Elect.	25 V	
C375	290-0139-00		180 μ F	Elect.	6 V	
C377	290-0247-00		5.6 μ F	Elect.	6 V	10%
C379	285-0808-00		0.1 μ F	MT	50 V	10%
C383	281-0504-00		10 pF	Cer	500 V	10%
C414	281-0592-00		4.7 pF	Cer		± 0.5 pF
C415	290-0297-00		39 μ F	Elect.	10 V	10%
C443	281-0659-00		4.3 pF	Cer	500 V	± 0.25 pF
C444	281-0534-00		3.3 pF	Cer	500 V	± 0.25 pF
C445 ²						
C445A	285-0703-00		0.1 μ F	PTM	100 V	5%
C445B	285-0702-00		0.033 μ F	PTM	100 V	5%
C445C	285-0598-00		0.01 μ F	PTM	100 V	5%
C445D	285-0627-00		0.0033 μ F	PTM	100 V	5%
C445E	285-0862-00		0.001 μ F	PTM	100 V	10%
C445F	281-0546-00		330 pF	Cer	500 V	10%
C445H	283-0599-00		98 pF	Mica	500 V	5%
C445J	281-0515-00		27 pF	Cer	500 V	± 1.35 pF
C447	281-0509-00		15 pF	Cer	500 V	10%
C461	281-0114-00		1.3-5.4 pF, Var	Air		
C462	281-0557-00		1.8 pF	Cer	500 V	± 0.1 pF
C471	283-0111-00		0.1 μ F	Cer	50 V	
C514	281-0592-00		4.7 pF	Cer		± 0.5 pF
C543	281-0659-00		4.3 pF	Cer	500 V	± 0.25 pF
C545 ²						

²Not replaceable. Part of circuit board.

Capacitors (cont)

Ckt. No.	Tektronix Part No.	Serial/Model No. Eff	Disc	Description		
C547	281-0509-00		15 pF	Cer	500 V	10%
C561	283-0129-00		0.56 μ F	Cer	100 V	
C565	290-0272-00		47 μ F	Elect.	50 V	
C567	290-0309-00		100 μ F	Elect.	25 V	
C581	283-0167-00		0.1 μ F	Cer	100 V	10%
C585	283-0167-00		0.1 μ F	Cer	100 V	10%
C589	283-0167-00		0.1 μ F	Cer	100 V	10%

Semiconductor Device, Diodes

D132	*152-0323-00		Silicon	Tek Spec		
D133	*152-0323-00		Silicon	Tek Spec		
D142	*152-0185-00		Silicon	Replaceable by 1N4152		
D162	*152-0185-00		Silicon	Replaceable by 1N4152		
D232	*152-0323-00		Silicon	Tek Spec		
D233	*152-0323-00		Silicon	Tek Spec		
D242	*152-0185-00		Silicon	Replaceable by 1N4152		
D262	*152-0185-00		Silicon	Replaceable by 1N4152		
D272	*152-0185-00		Silicon	Replaceable by 1N4152		
D275	152-0212-00		Zener	1N936 500 mW, 9 V, 5% TC		
D285	152-0280-00		Zener	1N753A 400 mW, 6.2 V, 5%		
D293	*152-0185-00		Silicon	Replaceable by 1N4152		
D294	*152-0061-00		Silicon	Tek Spec		
D295	152-0243-00		Zener	1N965B 400 mW, 15 V, 5%		
D297	*152-0185-00		Silicon	Replaceable by 1N4152		
D299	152-0305-00		Zener	1N3045B 1W, 110 V, 5%		
D347	152-0280-00		Zener	1N753A 400 mW, 6.2 V, 5%		
D352	152-0212-00		Zener	1N936 500 mW, 9 V, 5% TC		
D355	*152-0405-00		Zener	Tek Spec 1 W, 15 V, 5%		
D415	152-0280-00		Zener	1N753A 400 mW, 6.2 V, 5%		
D420	*152-0185-00		Silicon	Replaceable by 1N4152		
D422	*152-0185-00		Silicon	Replaceable by 1N4152		
D444	*152-0185-00		Silicon	Replaceable by 1N4152		
D445	*152-0185-00		Silicon	Replaceable by 1N4152		
D464	152-0241-00		Zener	1N973B 400 mW, 33 V, 5%		
D520	*152-0185-00		Silicon	Replaceable by 1N4152		
D522	*152-0185-00		Silicon	Replaceable by 1N4152		
D563	152-0243-00		Zener	1N965B 400 mW, 15 V, 5%		
D565	152-0304-00		Zener	1N968B 400 mW, 20 V, 5%		
D567	*152-0405-00		Zener	Tek Spec 1 W, 15 V, 5%		

Fuses

F131	159-0024-00		$\frac{1}{16}$ A	3AG	Fast-Blo
F231	159-0024-00		$\frac{1}{16}$ A	3AG	Fast-Blo

Electrical Parts List—Type 3A9

Connectors

Ckt. No.	Tektronix Part No.	Serial/Model No. Eff	No. Disc	Description
J101	131-0352-01			Receptacle, electrical, female
J201	131-0352-01			Receptacle, electrical, female
J301	131-0352-01			Receptacle, electrical, female
J475	131-0352-01			Receptacle, electrical, female

Transistors

Q133	*151-1027-00		FET	Dual, Tek Spec
Q144	*151-0261-00		Silicon	Dual, TO-78, Tek Spec
Q154	*151-1028-00		FET	Tek Spec
Q163	*151-0192-00		Silicon	Replaceable by MPS 6521
Q164	*151-0228-00		Silicon	Tek Spec
Q254	*151-1028-00		FET	Tek Spec
Q283	151-0220-00		Silicon	2N4122
Q284	151-0208-00		Silicon	2N4036
Q294	*151-0136-00		Silicon	Replaceable by 2N3053
Q295	*151-0228-00		Silicon	Tek Spec
Q314	*151-0261-00		Silicon	Dual, TO-78, Tek Spec
Q324	*151-1028-00		FET	Tek Spec
Q326	*151-0192-00		Silicon	Replaceable by MPS 6521
Q334	*151-1028-00		FET	Tek Spec
Q370	*151-0216-00		Silicon	Replaceable by MPS 6523
Q375	*151-0192-00		Silicon	Replaceable by MPS 6521
Q404	*151-1027-00		FET	Dual, Tek Spec
Q414	*151-0261-00		Silicon	Dual, TO-78, Tek Spec
Q424	151-0190-00		Silicon	2N3904
Q434	*151-0192-00		Silicon	Replaceable by MPS 6521
Q444	151-0188-00		Silicon	2N3906
Q454	*151-0150-00		Silicon	Selected from 2N3440
Q464	*151-1028-00		FET	Tek Spec
Q474	151-0188-00		Silicon	2N3906
Q524	151-0190-00		Silicon	2N3904
Q534	*151-0192-00		Silicon	Replaceable by MPS 6521
Q544	151-0188-00		Silicon	2N3906
Q554	*151-0150-00		Silicon	Selected from 2N3440

Resistors

Resistors are fixed, composition, $\pm 10\%$ unless otherwise indicated.

R101	315-0105-00	1 M Ω	$\frac{1}{4}$ W		5%
R105C	323-0611-03	900 k Ω	$\frac{1}{2}$ W	Prec	$\frac{1}{4}\%$
R105D	321-0389-03	110 k Ω	$\frac{1}{8}$ W	Prec	$\frac{1}{4}\%$
R105E	311-0496-00	2.5 k Ω , Var			
R107C	323-0614-03	990 k Ω	$\frac{1}{2}$ W	Prec	$\frac{1}{4}\%$

Resistors (cont)

Ckt. No.	Tektronix Part No.	Serial/Model No. Eff	Disc	Description		
R107D	321-0289-03		10 kΩ	1/8 W	Prec	1/4%
R107E	311-0442-00		250 Ω, Var			
R109C	323-0623-03		99 kΩ	1/2 W	Prec	1/4%
R109D	321-0637-00		9.9 kΩ	1/8 W	Prec	1/2%
R109E	311-0496-00		2.5 kΩ, Var			
R109F	321-0197-02		1.1 kΩ	1/8 W	Prec	1/2%
R111	315-0102-00		1 kΩ	1/4 W		5%
R113	323-0481-01		1 MΩ	1/2 W	Prec	1/2%
R115	311-0433-00		100 Ω, Var			
R121	321-0344-00		37.4 kΩ	1/8 W	Prec	1%
R122	307-0181-00		100 kΩ	Thermal		10%
R123	321-0155-00		402 Ω	1/8 W	Prec	1%
R124	307-0181-00		100 kΩ	Thermal		10%
R126	315-0302-00		3 kΩ	1/4 W		5%
R131	315-0512-00		5.1 kΩ	1/4 W		5%
R132	315-0510-00		51 Ω	1/4 W		5%
R134	308-0495-00		4.5 kΩ	2.5 W	WW	1/10%
R143	321-0614-00		10.1 kΩ	1/8 W	Prec	1%
R151	308-0497-00		105 Ω	2.5 W	WW	1%
R153	321-0114-00		150 Ω	1/8 W	Prec	1%
R154	316-0221-00		220 Ω	1/4 W		
R156	321-0030-00		20 Ω	1/8 W	Prec	1%
R157	308-0436-00		2 kΩ	3 W	WW	1/10%
R163	316-0105-00		1 MΩ	1/4 W		
R164	316-0105-00		1 MΩ	1/4 W		
R166	315-0113-00		11 kΩ	1/4 W		5%
R167	315-0102-00		1 kΩ	1/4 W		5%
R171	315-0223-00		22 kΩ	1/4 W		5%
R172	315-0184-00		180 kΩ	1/4 W		5%
R174	316-0223-00		22 kΩ	1/4 W		
R176	321-0408-00		174 kΩ	1/8 W	Prec	1%
R177	321-0303-00		14 kΩ	1/8 W	Prec	1%
R179	301-0165-00		1.6 MΩ	1/2 W		5%
R201	315-0105-00		1 MΩ	1/4 W		5%
R205C	323-0611-03		900 kΩ	1/2 W	Prec	1/4%
R205D	321-1389-03		111 kΩ	1/8 W	Prec	1/4%
R207C	323-0614-03		990 kΩ	1/2 W	Prec	1/4%
R207D	321-1289-03		10.1 kΩ	1/8 W	Prec	1/4%
R209C	323-0623-03		999 kΩ	1/2 W	Prec	1/4%
R209D	321-0193-03		1 kΩ	1/8 W	Prec	1/4%
R211	315-0102-00		1 kΩ	1/4 W		5%
R213	323-0481-01		1 MΩ	1/2 W	Prec	1/2%
R215	311-0433-00		100 Ω, Var			
R231	315-0512-00		5.1 kΩ	1/4 W		5%
R232	315-0510-00		51 Ω	1/4 W		5%

Electrical Parts List—Type 3A9

Resistors (cont)

Ckt. No.	Tektronix Part No.	Serial/Model No. Eff	Disc	Description		
R234	308-0495-00		4.5 k Ω	2.5 W	WW	1/10%
R243	321-0614-00		10.1 k Ω	1/8 W	Prec	1%
R251	308-0497-00		105 Ω	2.5 W	WW	1%
R253	321-0114-00		150 Ω	1/8 W	Prec	1%
R254	316-0221-00		220 Ω	1/4 W		
R256	321-0030-00		20 Ω	1/8 W	Prec	1%
R257	308-0436-00		2 k Ω	3 W	WW	1/10%
R258	315-0475-00		4.7 M Ω	1/4 W		5%
R259	311-0347-00		100 k Ω , Var			
R271	316-0222-00		2.2 k Ω	1/4 W		
R273	308-0112-00		6 k Ω	5 W	WW	1%
R276	321-0408-00		174 k Ω	1/8 W	Prec	1%
R277	321-0303-00		14 k Ω	1/8 W	Prec	1%
R279	301-0165-00		1.6 M Ω	1/2 W		5%
R283	315-0222-00		2.2 k Ω	1/4 W		5%
R284	315-0302-00		3 k Ω	1/4 W		5%
R293	316-0221-00		220 Ω	1/4 W		
R294	308-0492-00		8.15 k Ω	3 W	WW	1%
R295	306-0102-00		1 k Ω	2 W		
R297	303-0333-00		33 k Ω	1 W		5%
R314	315-0754-00		750 k Ω	1/4 W		5%
R321	308-0550-00		400 Ω	2.5 W	WW	1/10%
R326	308-0319-00		4.5 k Ω	3 W	WW	1%
R331	308-0550-00		400 Ω	2.5 W	WW	1/10%
R334	315-0754-00		750 k Ω	1/4 W		5%
R337	316-0222-00		2.2 k Ω	1/4 W		
R339	308-0549-00		6.3 k Ω	3 W	WW	1%
R341	308-0498-00		2.94 k Ω	2.5 W	WW	1%
R342	321-0135-00		249 Ω	1/8 W	Prec	1%
R343	321-0135-00		249 Ω	1/8 W	Prec	1%
R345	311-0658-00		500 Ω , Var			
R347	308-0498-00		2.94 k Ω	2.5 W	WW	1%
R351	321-0160-00		453 Ω	1/8 W	Prec	1%
R352	321-0415-00		205 k Ω	1/8 W	Prec	1%
R353	321-0415-00		205 k Ω	1/8 W	Prec	1%
R354	321-0160-00		453 Ω	1/8 W	Prec	1%
R355A	311-0843-00		50 k Ω , Var			
R355B	311-0360-01		5 k Ω , Var			
R371	321-0010-00		12.4 Ω	1/8 W	Prec	1%
R373	311-0095-00		500 Ω , Var			
R375	315-0121-00		120 Ω	1/4 W		5%
R377	321-0010-00		12.4 Ω	1/8 W	Prec	1%
R379	315-0105-00		1 M Ω	1/4 W		5%
R381	316-0391-00		390 Ω	1/4 W		
R383	316-0473-00		47 k Ω	1/4 W		

Resistors (cont)

Ckt. No.	Tektronix Part No.	Serial/Model No. Eff	Disc	Description		
R385	316-0153-00		15 k Ω	$\frac{1}{4}$ W		
R387	315-0152-00		1.5 k Ω	$\frac{1}{4}$ W		5%
R389	316-0221-00		220 Ω	$\frac{1}{4}$ W		
R391	315-0302-00		3 k Ω	$\frac{1}{4}$ W		5%
R401	315-0102-00		1 k Ω	$\frac{1}{4}$ W		5%
R404	308-0366-00		3.4 k Ω	3 W	WW	1%
R405	311-0867-00		30 Ω , Var			
R407	321-0689-00		24.9 k Ω	$\frac{1}{8}$ W	Prec	$\frac{1}{2}$ %
R408A	321-0001-01		10 Ω	$\frac{1}{8}$ W	Prec	$\frac{1}{2}$ %
R408B	321-0762-01		20.1 Ω	$\frac{1}{8}$ W	Prec	$\frac{1}{2}$ %
R408C	321-1068-01		50.5 Ω	$\frac{1}{8}$ W	Prec	$\frac{1}{2}$ %
R408D	321-0098-01		102 Ω	$\frac{1}{8}$ W	Prec	$\frac{1}{2}$ %
R408E	321-0127-01		205 Ω	$\frac{1}{8}$ W	Prec	$\frac{1}{2}$ %
R408F	321-1166-01		530 Ω	$\frac{1}{8}$ W	Prec	$\frac{1}{2}$ %
R408H	321-0763-07		1.12 k Ω	$\frac{1}{8}$ W	Prec	1/10%
R408J	321-1231-01		2.52 k Ω	$\frac{1}{8}$ W	Prec	$\frac{1}{2}$ %
R408K	321-1289-01		10.1 k Ω	$\frac{1}{8}$ W	Prec	$\frac{1}{2}$ %
R412	321-0329-00		26.1 k Ω	$\frac{1}{8}$ W	Prec	1%
R421	301-0912-00		9.1 k Ω	$\frac{1}{2}$ W		5%
R423	321-0282-00		8.45 k Ω	$\frac{1}{8}$ W	Prec	1%
R424	321-0233-00		2.61 k Ω	$\frac{1}{8}$ W	Prec	1%
R425	311-0462-00		1 k Ω , Var			
R427	321-0259-00		4.87 k Ω	$\frac{1}{8}$ W	Prec	1%
R428	316-0221-00		220 Ω	$\frac{1}{4}$ W		
R429	316-0221-00		220 Ω	$\frac{1}{4}$ W		
R431	321-0328-00		25.5 k Ω	$\frac{1}{8}$ W	Prec	1%
R433	321-0196-00		1.07 k Ω	$\frac{1}{8}$ W	Prec	1%
R437	321-0391-00		115 k Ω	$\frac{1}{8}$ W	Prec	1%
R440	311-0575-00		2 x 100 k Ω , Var			
R443	321-0305-00		14.7 k Ω	$\frac{1}{8}$ W	Prec	1%
R444	303-0103-00		10 k Ω	1 W		5%
R445	323-0366-00		63.4 k Ω	$\frac{1}{2}$ W	Prec	1%
R447	321-0254-00		4.32 k Ω	$\frac{1}{8}$ W	Prec	1%
R450	311-0642-00		20 k Ω , Var			
R454	308-0053-00		8 k Ω	5 W	WW	5%
R456	304-0681-00		680 Ω	1 W		
R457	316-0470-00		47 Ω	$\frac{1}{4}$ W		
R461	315-0474-00		470 k Ω	$\frac{1}{4}$ W		5%
R462	315-0753-00		75 k Ω	$\frac{1}{4}$ W		5%
R463	316-0391-00		390 Ω	$\frac{1}{4}$ W		
R464	305-0822-00		8.2 k Ω	2 W		5%
R465	315-0204-00		200 k Ω	$\frac{1}{4}$ W		5%
R467	311-0465-00		100 k Ω , Var			
R469	303-0203-00		20 k Ω	1 W		5%
R471	321-0253-00		4.22 k Ω	$\frac{1}{8}$ W	Prec	1%

Electrical Parts List—Type 3A9

Resistors (cont)

Ckt. No.	Tektronix Part No.	Serial/Model No. Eff	No. Disc	Description		
R473	322-0289-00		10 kΩ	1/4 W	Prec	1%
R474	301-0623-00		62 kΩ	1/2 W		5%
R475	315-0470-00		47 Ω	1/4 W		5%
R476	316-0101-00		100 Ω	1/4 W		
R501	315-0102-00		1 kΩ	1/4 W		5%
R504	308-0366-00		3.4 kΩ	3 W	WW	1%
R505	321-0018-00		15 Ω	1/8 W	Prec	1%
R512	321-0329-00		26.1 kΩ	1/8 W	Prec	1%
R523	321-0282-00		8.45 kΩ	1/8 W	Prec	1%
R524	321-0233-00		2.61 kΩ	1/8 W	Prec	1%
R527	321-0259-00		4.87 kΩ	1/8 W	Prec	1%
R528	316-0221-00		220 Ω	1/4 W		
R529	316-0221-00		220 Ω	1/4 W		
R531	321-0328-00		25.5 kΩ	1/8 W	Prec	1%
R533	321-0196-00		1.07 kΩ	1/8 W	Prec	1%
R535 ^a	311-0417-00		5 kΩ, Var			
R536	316-0564-00		560 kΩ	1/4 W		
R537	321-0391-00		115 kΩ	1/8 W	Prec	1%
R543	321-0305-00		14.7 kΩ	1/8 W	Prec	1%
R544	303-0103-00		10 kΩ	1 W		5%
R545	323-0366-00		63.4 kΩ	1/2 W	Prec	1%
R547	321-0254-00		4.32 kΩ	1/8 W	Prec	1%
R554	308-0053-00		8 kΩ	5 W	WW	5%
R557	316-0470-00		47 Ω	1/4 W		
R560	315-0161-00		160 Ω	1/4 W		5%
R561	316-0470-00		47 Ω	1/4 W		
R563	301-0102-00		1 kΩ	1/2 W		5%
R581	316-0470-00		47 Ω	1/4 W		
R583	308-0426-00		470 Ω	3 W	WW	5%
R585	316-0470-00		47 Ω	1/4 W		
R587	308-0314-00		680 Ω	3 W	WW	5%
R589	316-0470-00		47 Ω	1/4 W		

Switches

Wired or Unwired

SW101	260-0665-00	Lever	AC GND DC
SW175	Wired *262-0867-00	Rotary	AMPLIFIER —3 dB FREQUENCY (lower)
SW175	260-1045-00	Rotary	AMPLIFIER —3 dB FREQUENCY (lower)
SW201	260-0665-00	Lever	AC GND DC

^aFurnished as a unit with SW535.

Switches (cont)

Ckt. No.	Tektronix Part No.	Serial/Model No. Eff	No. Disc	Description
SW205	Wired *262-0866-00			Rotary
SW205	260-1044-00			Rotary
SW370	260-1046-00			Lever
				VOLTS/DIV
				VOLTS/DIV
				CURRENT VOLTS
SW445	Wired *262-0868-00			Rotary
SW445	260-1047-00			Rotary
SW535 ⁴	311-0417-00			
				AMPLIFIER —3 dB FREQUENCY (upper)
				AMPLIFIER —3 dB FREQUENCY (upper)

⁴Furnished as a unit with R535.

FIGURE AND INDEX NUMBERS

Items in this section are referenced by figure and index numbers to the illustrations which appear on the pullout pages immediately following the Diagrams section of this instruction manual.

INDENTATION SYSTEM

This mechanical parts list is indented to indicate item relationships. Following is an example of the indentation system used in the Description column.

Assembly and/or Component
Detail Part of Assembly and/or Component
mounting hardware for Detail Part
Parts of Detail Part
mounting hardware for Parts of Detail Part
mounting hardware for Assembly and/or Component

Mounting hardware always appears in the same indentation as the item it mounts, while the detail parts are indented to the right. Indented items are part of, and included with, the next higher indentation.

Mounting hardware must be purchased separately, unless otherwise specified.

PARTS ORDERING INFORMATION

Replacement parts are available from or through your local Tektronix, Inc. Field Office or representative.

Changes to Tektronix instruments are sometimes made to accommodate improved components as they become available, and to give you the benefit of the latest circuit improvements developed in our engineering department. It is therefore important, when ordering parts, to include the following information in your order: Part number, instrument type or number, serial or model number, and modification number if applicable.

If a part you have ordered has been replaced with a new or improved part, your local Tektronix, Inc. Field Office or representative will contact you concerning any change in part number.

Change information, if any, is located at the rear of this manual.

ABBREVIATIONS AND SYMBOLS

For an explanation of the abbreviations and symbols used in this section, please refer to the page immediately preceding the Electrical Parts List in this instruction manual.

INDEX OF MECHANICAL PARTS LIST ILLUSTRATIONS

(Located behind diagrams)

FIG. 1 EXPLODED

SECTION 7

MECHANICAL PARTS LIST

FIG. 1 EXPLODED

Fig. & Index No.	Tektronix Part No.	Serial/Model No. Eff Disc	Q					Description		
			†	y	1	2	3		4	5
1-1	366-0148-00		1						1	KNOB, charcoal—POSITION
	- - - - -		-						-	knob includes:
	213-0004-00		1						1	SCREW, set, 6-32 x 3/16 inch, HSS
-2	- - - - -		1						1	RESISTOR, variable
	- - - - -		-						-	mounting hardware: (not included w/resistor)
	210-0207-00		1						1	LUG, solder, 3/8 ID x 5/8 inch OD, SE
-3	210-0012-00		1						1	LOCKWASHER, internal, 3/8 ID x 1/2 inch OD
	210-0978-00		1						1	WASHER, flat, 3/8 ID x 1/2 inch OD
-4	210-0590-00		1						1	NUT, hex., 3/8-32 x 7/16 inch
-5	366-0215-01		1						1	KNOB, lever, charcoal—CURRENT VOLTS
-6	260-1046-00		1						1	SWITCH, lever—CURRENT VOLTS
	- - - - -		-						-	mounting hardware: (not included w/switch)
-7	220-0413-00		2						2	NUT, switch mounting
-8	366-0215-01		1						1	KNOB, lever, charcoal—AC GND DC
-9	260-0665-00		1						1	SWITCH, lever—AC GND DC
	- - - - -		-						-	mounting hardware: (not included w/switch)
-10	220-0413-00		2						2	NUT, switch mounting
-11	366-0215-01		1						1	KNOB, lever, charcoal—AC GND DC
-12	260-0665-00		1						1	SWITCH, lever—AC GND DC
	- - - - -		-						-	mounting hardware: (not included w/switch)
-13	220-0413-00		2						2	NUT, switch mounting
-14	366-0270-00		1						1	KNOB, charcoal—STEP ATTEN DC BAL
	- - - - -		-						-	knob includes:
	213-0075-00		1						1	SCREW, set, 4-40 x 3/16 inch, HSS
-15	- - - - -		1						1	RESISTOR, variable
	- - - - -		-						-	mounting hardware: (not included w/resistor)
-16	210-0223-00		1						1	LUG, solder, 1/4 ID x 7/16 inch OD, SE
	210-0940-00		1						1	WASHER, flat, 1/4 ID x 3/8 inch OD
-17	210-0583-00		1						1	NUT, hex., 1/4-32 x 5/16 inch
-18	366-0081-00		1						1	KNOB, red—VARIABLE
	- - - - -		-						-	knob includes:
	213-0004-00		1						1	SCREW, set, 6-32 x 3/16 inch, HSS
-19	366-0142-00		1						1	KNOB, charcoal—VOLTS/DIV
	- - - - -		-						-	knob includes:
	213-0004-00		1						1	SCREW, set, 6-32 x 3/16 inch, HSS

FIG. 1 EXPLODED (cont)

Fig. & Index No.	Tektronix Part No.	Serial/Model No. Eff Disc	Q					Description	
			†	Y	1	2	3		4
1-20	262-0866-00		1						SWITCH, wired—VOLTS/DIV
	- - - - -		-						switch includes:
	260-1044-00		1						SWITCH, unwired
-21	384-0442-00		1						SHAFT, extension
-22	376-0014-00		1						COUPLING
-23	- - - - -		1						RESISTOR, variable
	- - - - -		-						mounting hardware: (not included w/resistor)
-24	210-0413-00		2						NUT, hex., 3/8-32 x 1/2 inch
	210-0012-00		1						LOCKWASHER, internal, 3/8 ID x 1/2 inch OD
-25	- - - - -		1						RESISTOR, variable
	- - - - -		-						mounting hardware: (not included w/resistor)
	210-0940-00		1						WASHER, flat, 1/4 ID x 3/8 inch OD
-26	210-0583-00		1						NUT, hex., 1/4-32 x 5/16 inch
-27	407-0548-00		1						BRACKET
	- - - - -		-						mounting hardware: (not included w/bracket)
-28	213-0203-00		2						SCREW, 5-40 x 1/4 inch, PHS
-29	129-0185-00		2						POST, hex., 0.500 inch long
-30	210-0449-00		2						NUT, hex., 5-40 x 1/4 inch
-31	129-0198-00		3						POST, hex., 0.750 inch long
-32	211-0116-00		3						SCREW, sems, 4-40 x 5/16 inch, PHB
-33	670-1048-00		1						ASSEMBLY, circuit board—ATTENUATOR
	- - - - -		-						assembly includes:
	388-1178-00		1						BOARD, circuit
-34	131-0633-00		2						TERMINAL, pin
	- - - - -		-						mounting hardware: (not included w/assembly)
-35	352-0071-00		4						HOLDER, circuit board
-36	211-0116-00		4						SCREW, sems, 4-40 x 5/16 inch, PHB
	- - - - -		-						mounting hardware: (not included w/switch)
-37	210-0457-00		3						NUT, keps, 6-32 x 5/16 inch
-38	210-0012-00		1						LOCKWASHER, internal, 3/8 ID x 1/2 inch OD
-39	210-0413-00		1						NUT, hex., 3/8-32 x 1/2 inch
-40	366-0427-00		1						KNOB, charcoal—AMPLIFIER —3 dB FREQUENCY (upper)
	- - - - -		-						knob includes:
	213-0153-00		1						SCREW, set, 5-40 x 0.125 inch, HSS
-41	262-0868-00		1						SWITCH, wired—AMPLIFIER —3 dB FREQUENCY (upper)
	- - - - -		-						switch includes:
	260-1047-00		1						SWITCH, unwired
	- - - - -		-						mounting hardware: (not included w/switch)
-42	210-0413-00		1						NUT, hex., 3/8-32 x 1/2 inch
-43	366-0427-00		1						KNOB, charcoal—AMPLIFIER —3 dB FREQUENCY (lower)
	- - - - -		-						knob includes:
	213-0153-00		1						SCREW, set, 5-40 x 0.125 inch, HSS
-44	262-0867-00		1						SWITCH, wired—AMPLIFIER —3 dB FREQUENCY (lower)
	- - - - -		-						switch includes:
	260-1045-00		1						SWITCH, unwired
	- - - - -		-						mounting hardware: (not included w/switch)
-45	210-0413-00		1						NUT, hex., 3/8-32 x 1/2 inch

FIG. 1 EXPLODED (cont)

Fig. & Index No.	Tektronix Part No.	Serial/Model No.		Q † y	Description
		Eff	Disc		
1-46	366-1107-00			1	KNOB, gray—DC OFFSET COARSE
	- - - - -			-	knob includes:
	213-0075-00			1	SCREW, set, 4-40 x 3/16 inch, HSS
-47	366-0250-00			1	KNOB, charcoal—DC OFFSET FINE
	- - - - -			-	knob includes:
	213-0004-00			1	SCREW, set, 6-32 x 3/16 inch, HSS
-48	- - - - -			1	RESISTOR, variable
	- - - - -			-	resistor includes:
	213-0075-00			1	SCREW, set, 4-40 x 3/32 inch, HSS
	- - - - -			-	mounting hardware: (not included w/resistor)
-49	426-0289-00			1	MOUNT, plastic
-50	211-0017-00			2	SCREW, 4-40 x 3/4 inch, RHS
	210-0012-00			1	LOCKWASHER, internal, 3/8 ID x 1/2 inch OD
-51	210-0413-00			1	NUT, hex., 3/8-32 x 1/2 inch
-52	354-0325-00			1	RING, brake friction
-53	166-0025-00			4	SPACER, 1/4 inch long
	213-0075-00			1	SCREW, set, 4-40 x 3/32 inch, HSS (not shown)
-54	384-0696-00	B010100	B010199	1	SHAFT, extension, 1.891 inches long
	384-0302-00	B010200		1	SHAFT, extension, 2 inches long
-55	- - - - -			1	RESISTOR, variable
	- - - - -			-	mounting hardware: (not included w/resistor)
-56	210-0978-00			1	WASHER, flat, 3/8 ID x 1/2 inch OD
-57	210-0590-00			1	NUT, hex., 3/8-32 x 7/16 inch
-58	366-0261-00			1	KNOB, gray—LF COMP
-59	- - - - -			1	RESISTOR, variable
	- - - - -			-	mounting hardware: (not included w/resistor)
	213-0020-00			1	SCREW, set, 6-32 x 1/8 inch, HSS (not shown)
-60	358-0216-00			1	BUSHING, gray, plastic
-61	366-0109-00			1	KNOB, plug-in securing
	- - - - -			-	knob includes:
	213-0005-00			1	SCREW, set, 8-32 x 1/8 inch, HSS
-62	214-0052-00			1	FASTENER, pawl right w/stop
	- - - - -			-	mounting hardware: (not included w/fastener)
	210-0004-00			2	LOCKWASHER, internal, #4
-63	210-0406-00			2	NUT, hex., 4-40 x 3/16 inch
-64	131-0352-01			2	CONNECTOR, BNC, female, w/hardware
-65	131-0352-01			1	CONNECTOR, BNC, female, w/hardware
	- - - - -			-	mounting hardware: (not included w/connector)
-66	210-0255-00			1	LUG, solder, 3/8 inch
-67	131-0352-01			1	CONNECTOR, BNC, female
	- - - - -			-	mounting hardware: (not included w/connector)
	210-0255-00			1	LUG, solder, 3/8 inch
-68	210-0494-00			1	NUT, hex., 3/8-32 x 1/2 x 11/16 inch

Mechanical Parts List—Type 3A9

FIG. 1 EXPLODED (cont)

Fig. & Index No.	Tektronix Part No.	Serial/Model Eff	No. Disc	Q t y	1 2 3 4 5					Description
					1	2	3	4	5	
1-69	200-0103-00			1						CAP, binding post
-70	355-0507-00			1						STEM, binding post
	- - - - -			-						mounting hardware: (not included w/stem)
	210-0223-00			1						LUG, solder, 1/4 ID x 7/16 inch OD, SE
-71	210-0455-00			1						NUT, hex., 1/4-28 x 3/8 inch
-72	352-0084-00			2						HOLDER, neon
-73	378-0541-00			2						FILTER, lens, neon
-74	200-0609-00			2						CAP, neon holder
-75	348-0031-00			2						GROMMET, plastic, 3/32 inch diameter
-76	333-1104-01			1						PANEL, front
-77	386-1463-00			1						SUB-PANEL, front
-78	384-0441-00	B010100	B010199	1						SHAFT, extension, 4.204 inches long
	384-0268-00	B010200		1						SHAFT, extension, 4.907 inches long
-79	384-0454-01			1						SHAFT, extension, 7.125 inches long, w/plastic end
-80	384-0443-00	B010100	B010199	2						SHAFT, extension, 7.486 inches long
	384-0695-00	B010200		1						SHAFT, extension, 7.730 inches long
-81	376-0008-00			2						COUPLING, 7/8 inch long
	- - - - -			-						each coupling includes:
	213-0005-00			2						SCREW, set, 8-32 x 1/8 inch, HSS
-82	376-0029-00			1						COUPLING, shaft, 1/2 inch long
	- - - - -			-						coupling includes:
	213-0075-00			2						SCREW, set, 4-40 x 3/32 inch, HSS
-83	337-1114-00			1						SHIELD, circuit board
	- - - - -			-						mounting hardware: (not included w/shield)
-84	211-0008-00			3						SCREW, 4-40 x 1/4 inch, PHS
-85	407-0547-00			1						BRACKET, angle
	- - - - -			-						mounting hardware: (not included w/bracket)
-86	210-0457-00			2						NUT, keps, 6-32 x 5/16 inch
-87	441-0810-00			1						CHASSIS
	- - - - -			-						mounting hardware: (not included w/chassis)
-88	210-0457-00			6						NUT, keps, 6-32 x 5/16 inch
-89	211-0538-00			3						SCREW, 6-32 x 5/16 inch, 100° csk, FHS
-90	211-0507-00			3						SCREW, 6-32 x 5/16 inch, PHS
-91	348-0056-00			3						GROMMET, plastic, 3/8 inch diameter
-92	354-0068-00			2						RING, securing, plastic
-93	124-0093-00			2						STRIP, ceramic, 7/16 inch h, w/5 notches
	- - - - -			-						each strip includes:
-94	355-0082-00			2						STUD, plastic
	- - - - -			-						mounting hardware for each: (not included w/strip)
-95	361-0009-00			2						SPACER, plastic, 9/32 inch long
-96	129-0203-00			1						POST, hex., 1.140 inches long
	- - - - -			-						mounting hardware: (not included w/post)
-97	211-0008-00			1						SCREW, 4-40 x 1/4 inch, PHS

FIG. 1 EXPLODED (cont)

Fig. & Index No.	Tektronix Part No.	Serial/Model No.		Q t Y	Description
		Eff	Disc		
1-98	214-0757-00			2	HEAT SINK, transistor w/hardware
-99	337-1128-00			1	SHIELD
	- - - - -			-	mounting hardware: (not included w/shield)
-100	211-0008-00			2	SCREW, 4-40 x 1/4 inch, PHS
-101	352-0136-00			1	HOLDER, fuse, dual
	- - - - -			-	mounting hardware: (not included w/holder)
-102	213-0088-00			2	SCREW, thread forming, 4-40 x 1/4 inch, PHS
-103	343-0088-00			2	CLAMP, cable, plastic, small
-104	670-1049-00			1	ASSEMBLY, circuit board—AMPLIFIER
	- - - - -			-	assembly includes:
	388-1179-00			1	BOARD, circuit
-105	344-0119-00			6	CLIP, electrical
-106	344-0154-00			4	CLIP, fuse
-107	131-0505-00			4	TERMINAL, stud
-108	131-0633-00			50	TERMINAL, pin
-109	136-0183-00			10	SOCKET, transistor, 3 pin
-110	136-0220-00			11	SOCKET, transistor, 3 pin
-111	136-0235-00			5	SOCKET, transistor, 6 pin
-112	200-0687-01			1	COVER, transistor
	- - - - -			-	mounting hardware: (not included w/assembly)
-113	211-0116-00			6	SCREW, sems, 4-40 x 5/16 inch, PHB
-114	129-0202-00			3	POST, hex., plastic, 0.801 inch long
	- - - - -			-	mounting hardware for each: (not included w/post)
-115	211-0116-00			1	SCREW, sems, 4-40 x 5/16 inch, PHB
-116	200-0828-00			1	COVER, plastic
	- - - - -			-	mounting hardware: (not included w/cover)
-117	211-0008-00			1	SCREW, 4-40 x 1/4 inch, PHS
-118	385-0149-00			1	ROD, spacer, plastic, 5/8 inch long
-119	211-0116-00			1	SCREW, sems, 4-40 x 5/16 inch, PHB
-120	337-1043-00			1	SHIELD, circuit board
	- - - - -			-	mounting hardware: (not included w/shield)
-121	211-0008-00			4	SCREW, 4-40 x 1/4 inch, PHS
-122	179-1368-00			1	CABLE HARNESS
	- - - - -			-	cable harness includes:
-123	131-0371-00			32	CONNECTOR, single contact
-124	131-0371-00			20	CONNECTOR, single contact
-125	384-0615-00			4	ROD, spacer
-126	210-0202-00			1	LUG, solder, SE #6
	- - - - -			-	mounting hardware: (not included w/lug)
-127	211-0504-00			1	SCREW, 6-32 x 1/4 inch, PHS
-128	210-0457-00			1	NUT, keps, 6-32 x 5/16 inch

Mechanical Parts List—Type 3A9

FIG. 1 EXPLODED (cont)

Fig. & Index No.	Tektronix Part No.	Serial/Model Eff	No. Disc	Q					Description	
				t	y	1	2	3		4
1-129	131-0149-00			1						CONNECTOR, 24 contact, male
	- - - - -			-						mounting hardware: (not included w/connector)
-130	211-0008-00			2						SCREW, 4-40 x 1/4 inch, PHS
-131	210-0586-00			2						NUT, keps, 4-40 x 1/4 inch
-132	351-0037-00			1						GUIDE
	- - - - -			-						mounting hardware: (not included w/guide)
-133	211-0012-00			1						SCREW, 4-40 x 3/8 inch, PHS
	210-0004-00			1						LOCKWASHER, internal, #4
-134	210-0406-00			1						NUT, hex., 4-40 x 3/16 inch
-135	387-0581-00			1						PANEL, rear
	- - - - -			-						mounting hardware: (not included w/panel)
-136	212-0023-00			4						SCREW, 8-32 x 3/8 inch, PHS

STANDARD ACCESSORIES

070-0913-00	2	MANUAL, instruction (not shown)
-------------	---	---------------------------------

SECTION 8

DIAGRAMS

The following symbols are used on the diagrams:



Screwdriver adjustment

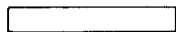

Front panel control or connector



Refer to indicated diagram

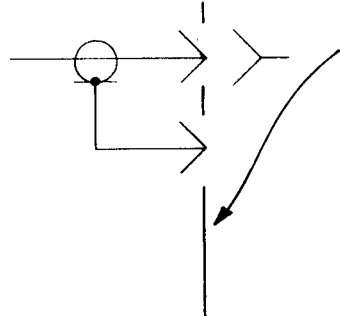

Blue line encloses components located on circuit board

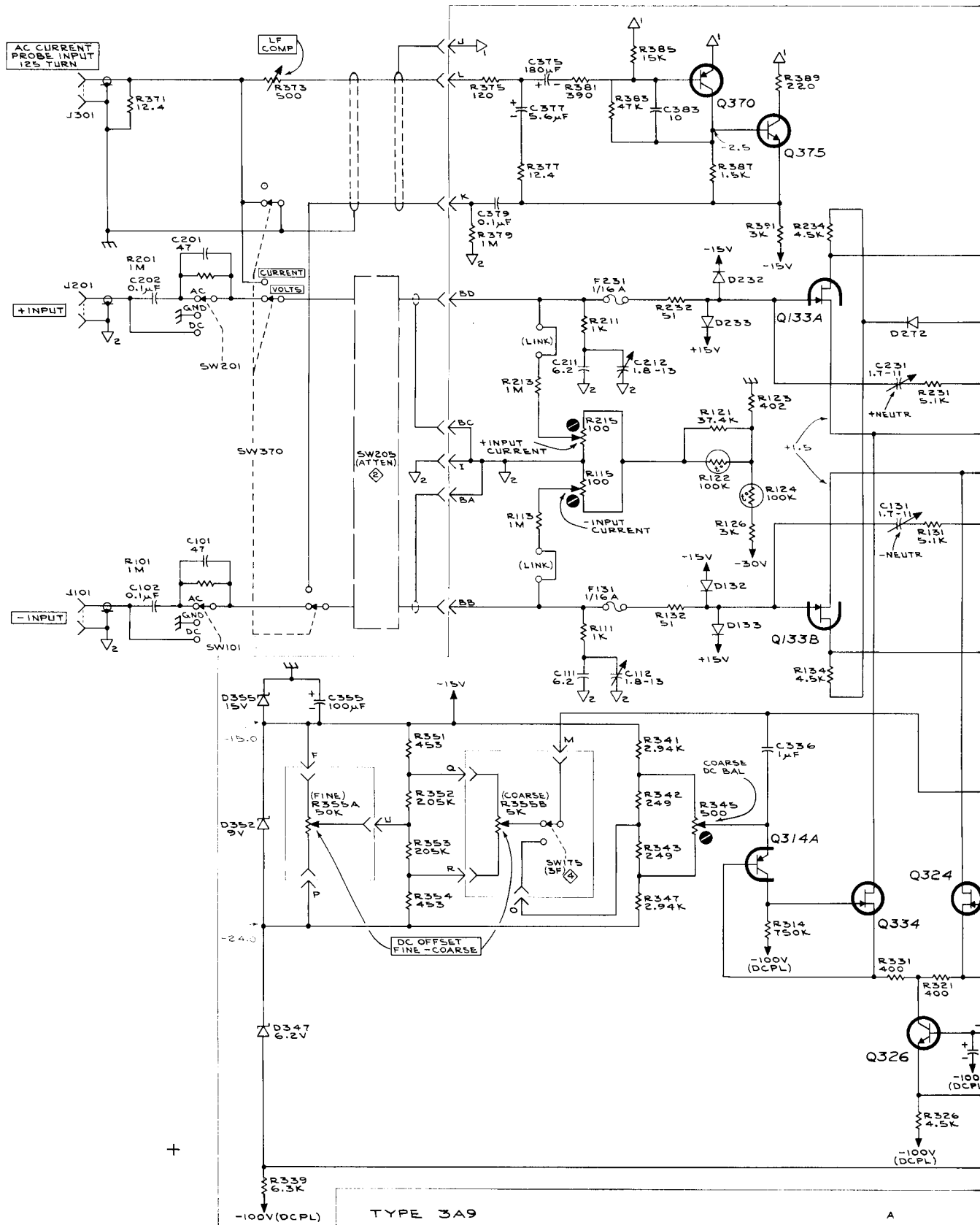

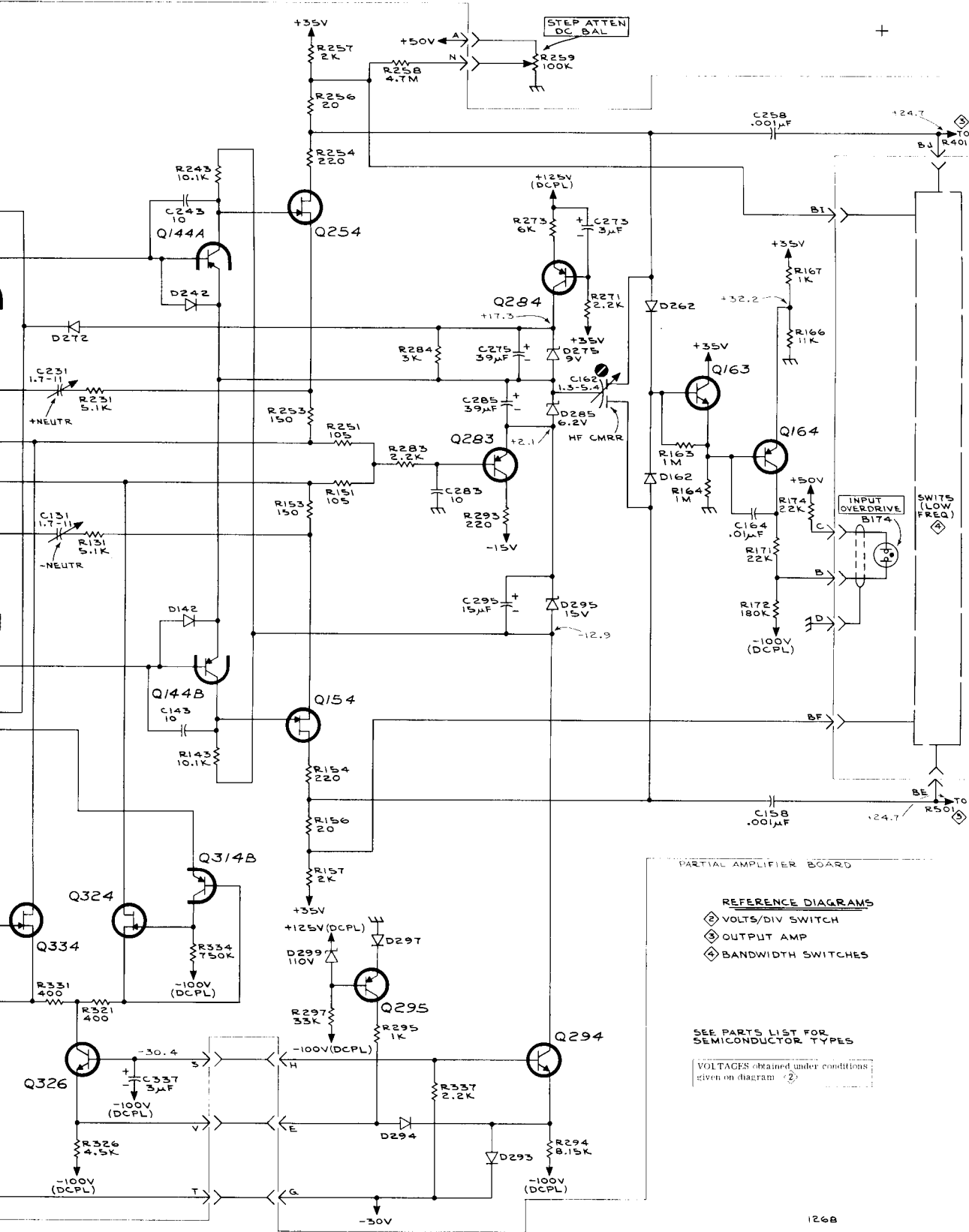

PARTIAL AMPLIFIER BOARD

REFERENCE DIAGRAMS

- ⊠ VOLTS/DIV SWITCH
- ⊠ OUTPUT AMP
- ⊠ BANDWIDTH SWITCHES

SEE PARTS LIST FOR SEMICONDUCTOR TYPES

VOLTAGES obtained under conditions given on diagram (2)

IMPORTANT

Circuit voltages measured with an electronic voltmeter, having an input resistance of $100\text{ M}\Omega \pm 5\%$, and a meter accuracy of $\pm 2\%$. Voltages are measured with respect to chassis ground unless otherwise noted. If a $20,000\Omega/\text{volt}$ VOM is used, the effects of circuit loading at high impedance points must be taken into consideration.

Voltages on the schematics (shown in blue) are not absolute and may vary between instruments because of component tolerances.

The Type 3A9 controls are set as follows:

POSITION	Midrange
VOLTS/DIV	10 mV
VARIABLE	CAL
-3dB FREQUENCY UPPER	1 MHz
-3dB FREQUENCY LOWER	DC
AC-GND-DC + INPUT	GND
AC-GND-DC - INPUT	GND
STEP ATTEN DC BAL	Midrange
DC OFFSET COARSE	Midrange
DC OFFSET FINE	Midrange
CURRENT-VOLTS	VOLTS

The time-base controls were set as follows:

Time/Div	.5 ms
Variable	Calib
Slope	+
Coupling	AC
Source	Int
Trigger Mode	Free Run

Voltage conditions are described on Diagram 

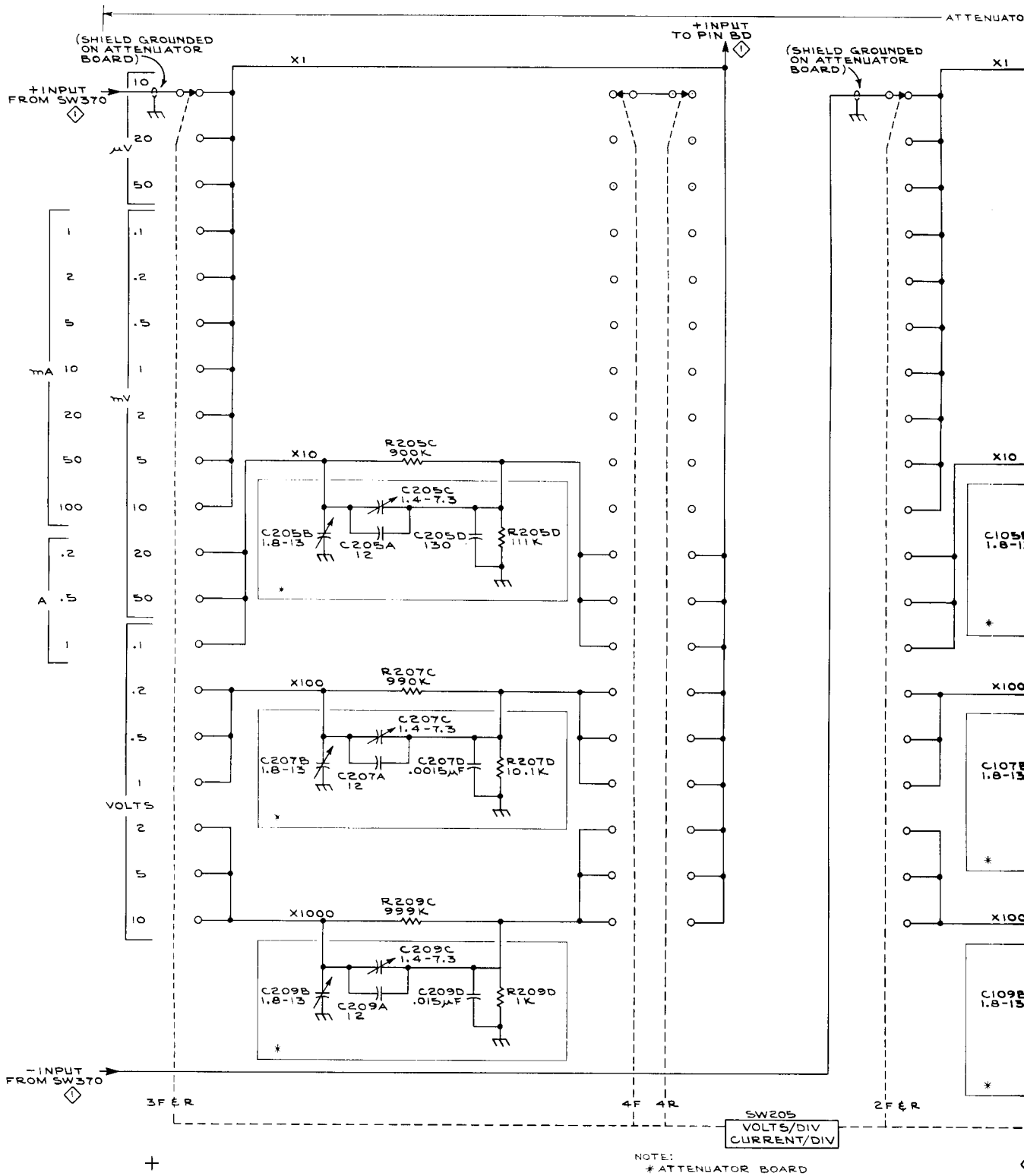

TYPE 3A9

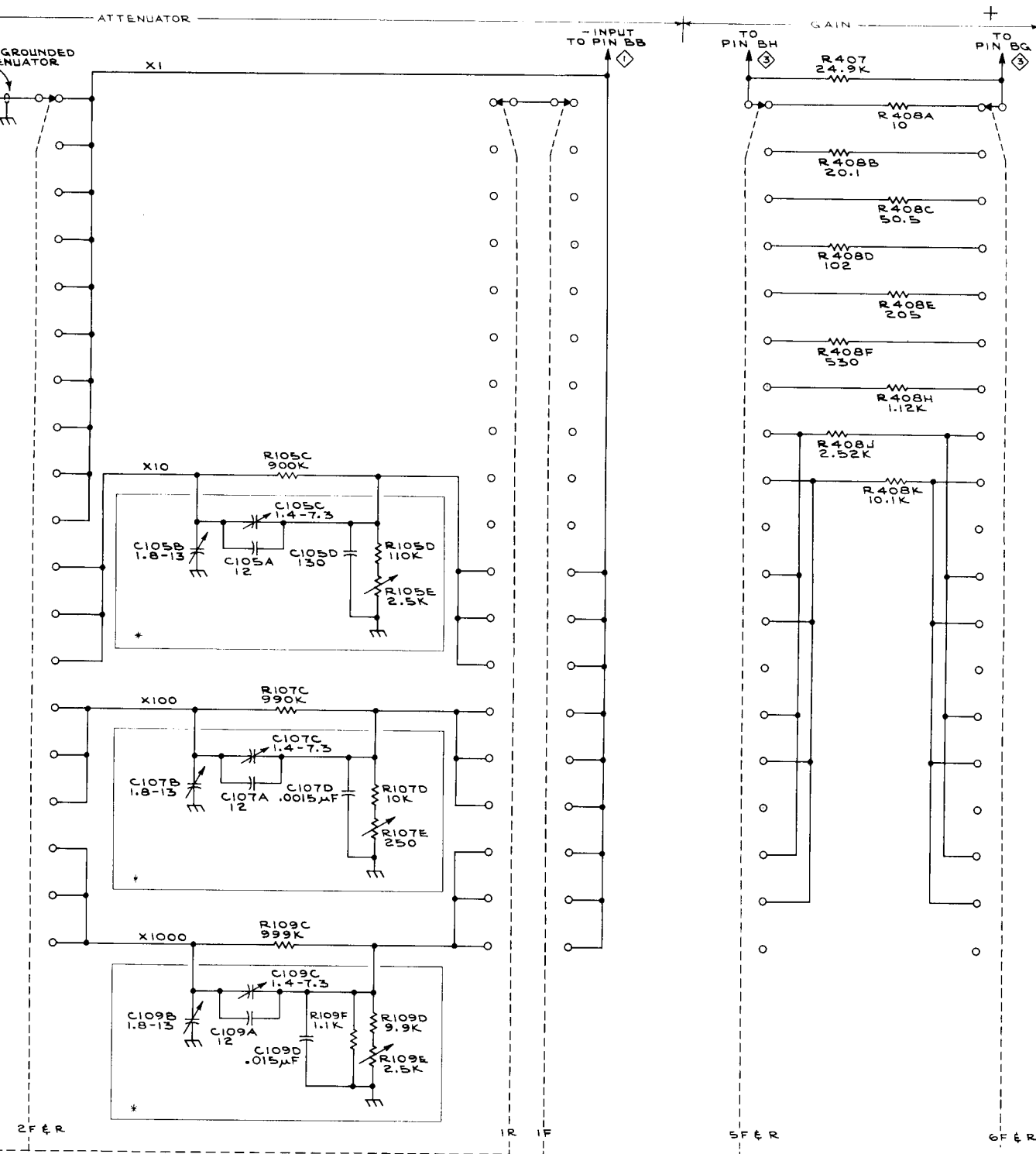

VOLTS/DIV SWITCH 2

REFERENCE DIAGRAMS

- ① PREAMP
- ③ OUTPUT AMP

A

VOLTS/DIV SWITCH 2

1268

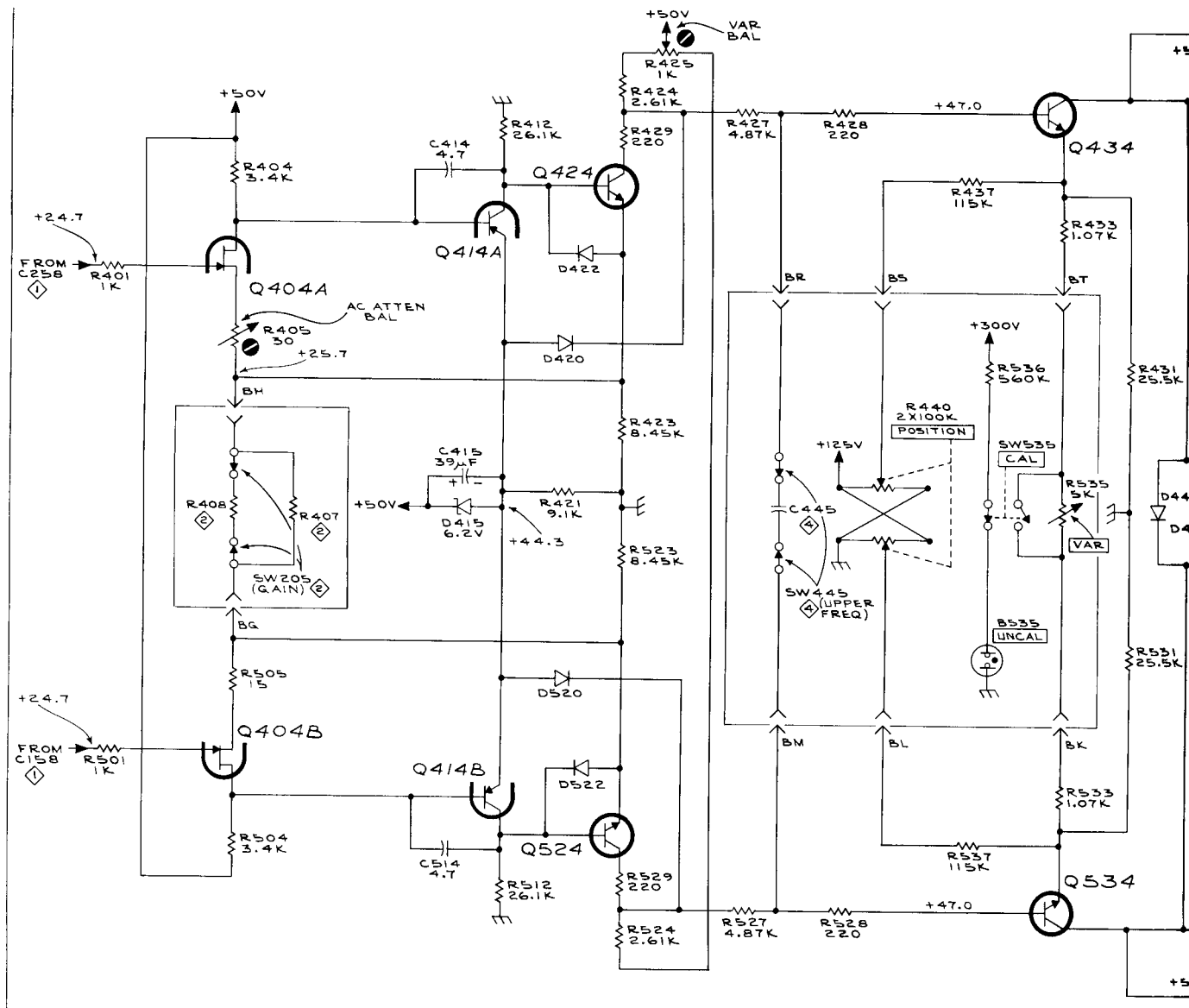

REFERENCE DIAGRAMS

- ◇ PREAMP
- ◇ VOLTS/DIV SWITCH
- ◇ BANDWIDTH SWITCHES

SEE PARTS LIST FOR SEMICONDUCTOR TYPES

VOLTAGES obtained under conditions given on diagram ②

+

TYPE 3A9

A

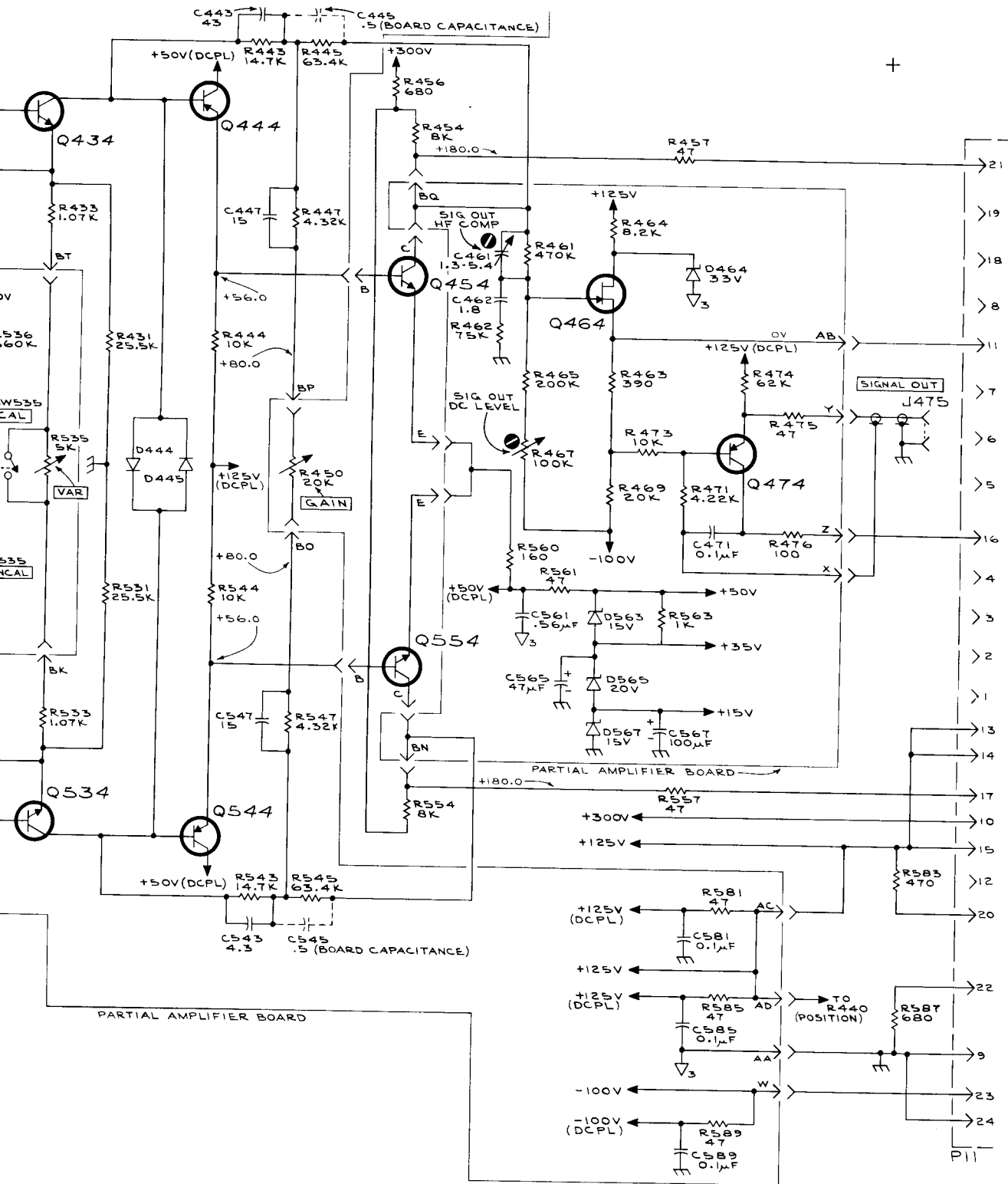

OUTPUT AMP

3

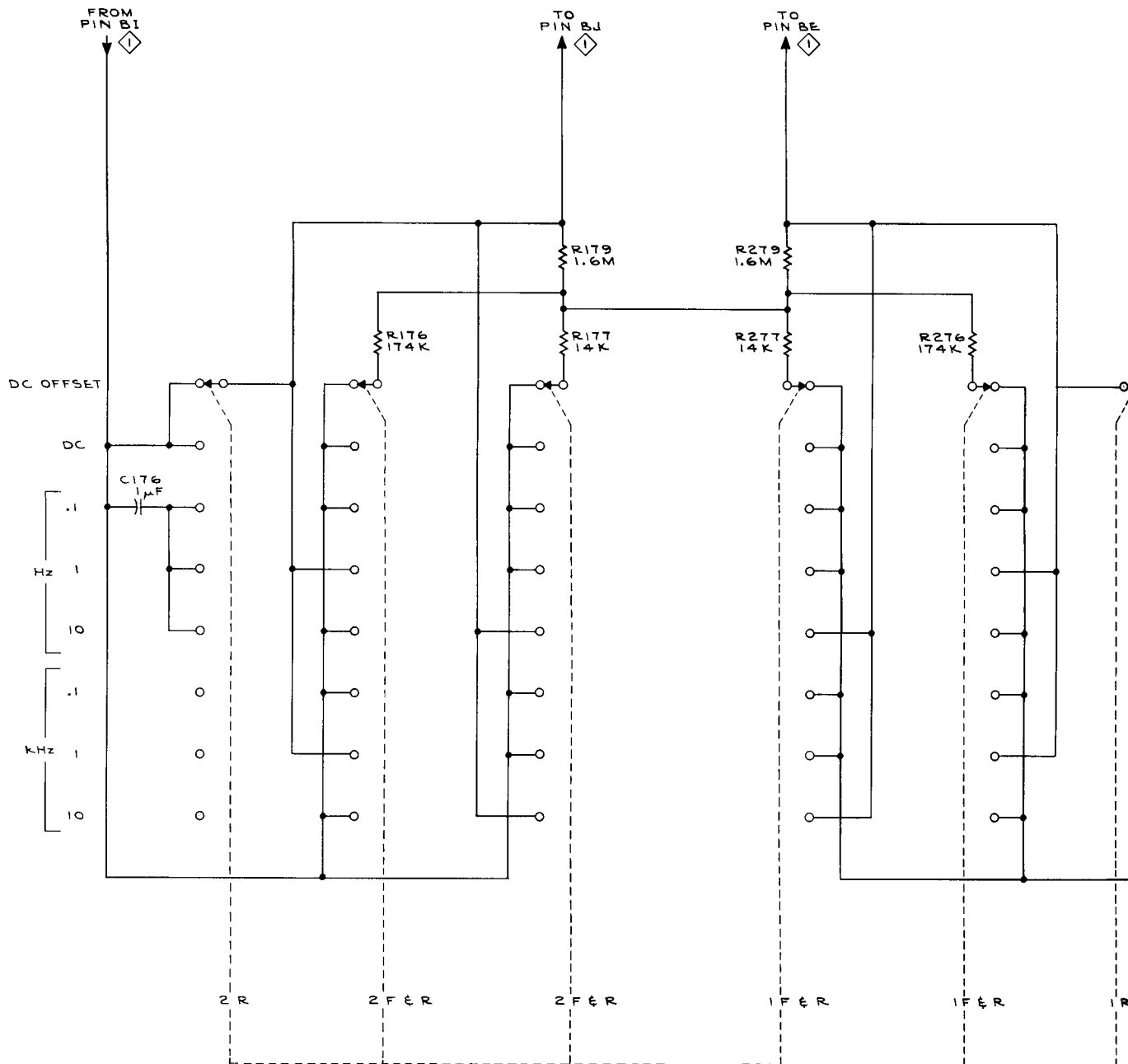

REFERENCE DIAGRAMS

- (1) PREAMP
- (3) OUTPUT AMP

TYPE 3A9

A

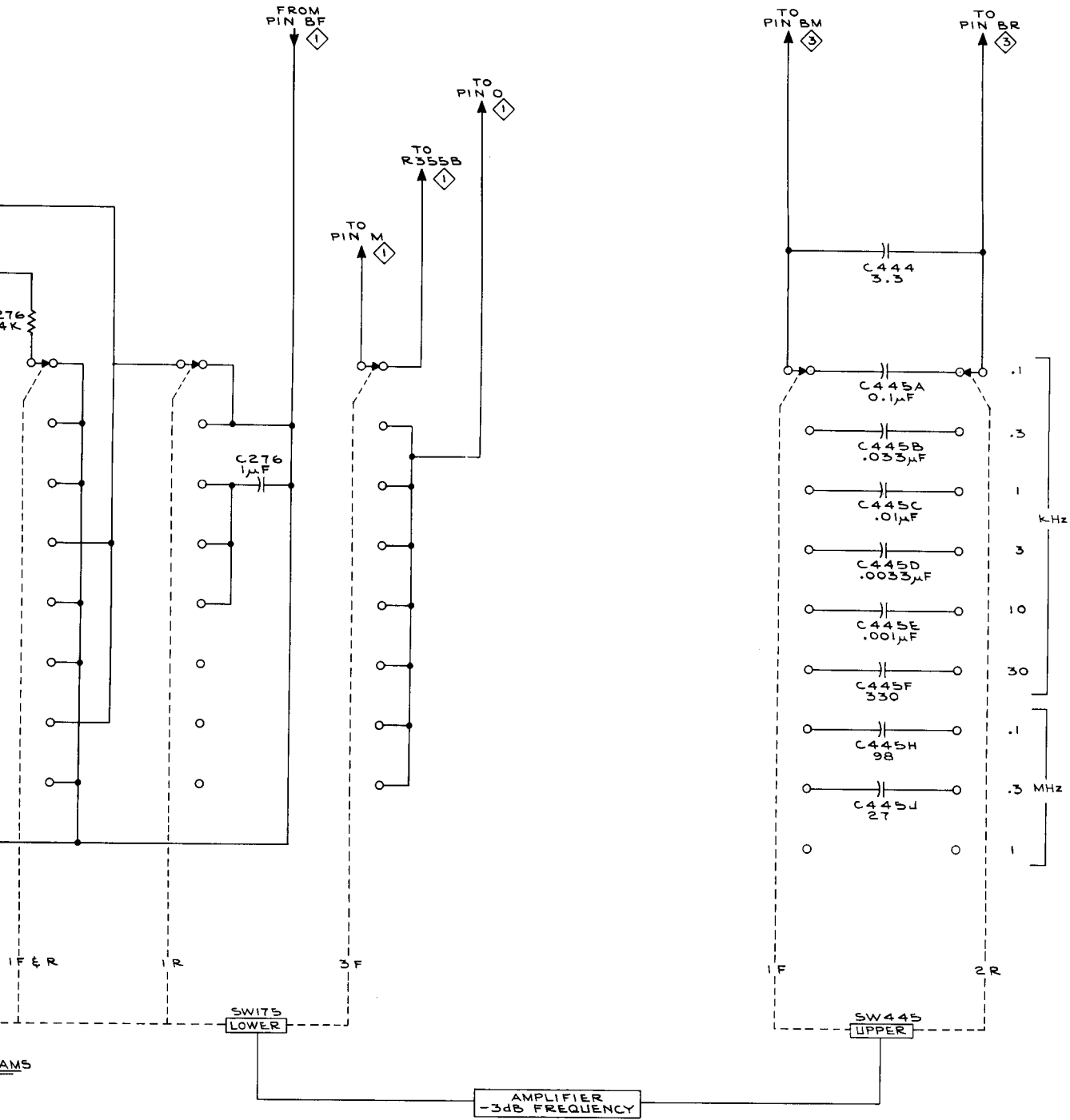

1268

BANDWIDTH SWITCHES 4

FIG. 1 EXPLODED

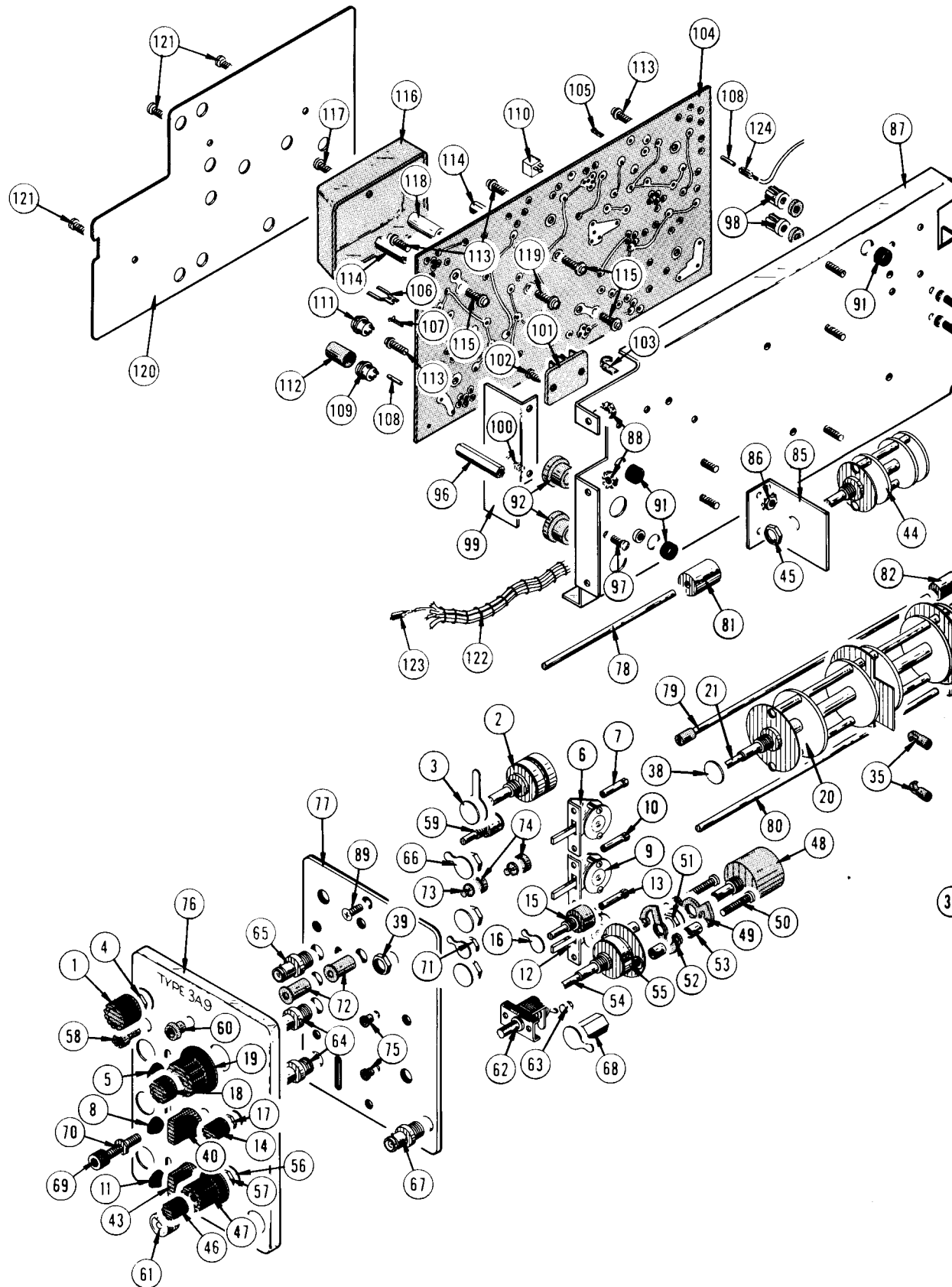
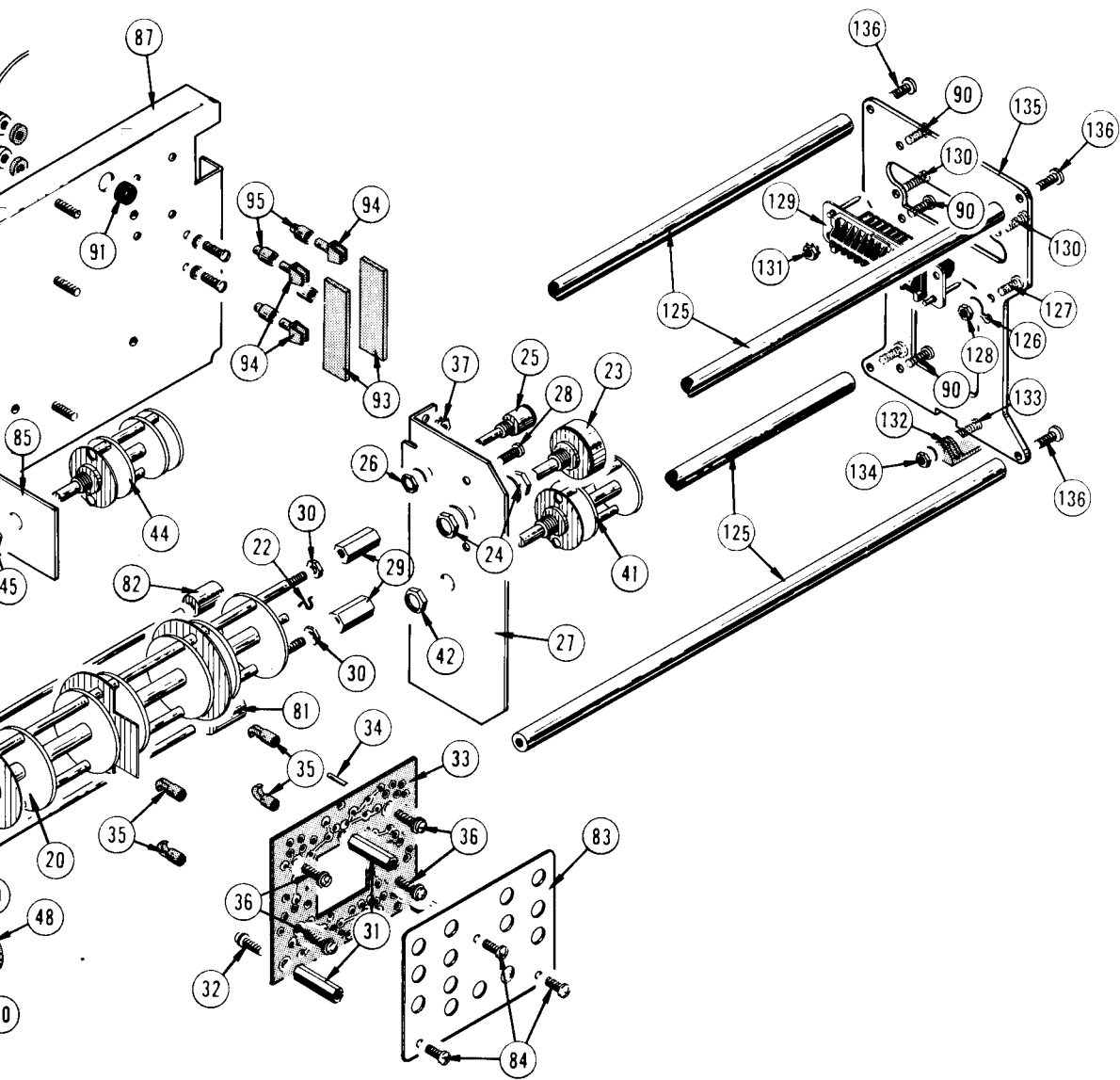

FIG. 1 EXPLODED

+

FIG. 1



TYPE 3A9 DIFFERENTIAL AMPLIFIER

Type 3A9

ELECTRICAL PARTS LIST CORRECTION

Section 6

Page 6-6

ADD:

R372 315-0621-00 620 Ω (Nominal value) Selected $\frac{1}{4}$ W 5%

SCHEMATIC CORRECTION

Preamp

ADD:

R372

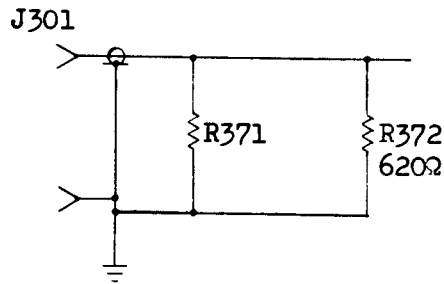

Partial Preamp Board